

11. Personnel & Collective Bargaining

Co-Chairs Alderperson Mietzner & Alderperson Holmes

a. Other Pertinent Information

12. Adjournment

The next Committee of the Whole meeting is scheduled for Tuesday, March 12, 2024, at 5:30 PM.

Minutes of the Committee of the Whole
Wilmington City Hall
1165 South Water Street
January 9, 2024

Call to Order

The Committee of the Whole meeting on January 9, 2024, was called to order at 5:30 p.m. by Mayor Dietz in the Council Chamber of Wilmington City Hall.

Roll Call

Upon Roll Call by the Clerk the following members of the corporate authorities answered "Here" or "Present":

Alderspersons Present Kirwin, Jeffries, Vice, Knight, Allred, Mietzner, Smith, Holmes

Quorum

There were sufficient members of the corporate authorities in attendance to constitute a quorum, so the meeting was declared in order.

Other Officials in Attendance

Also, in attendance was the City Administrator Jeannine Smith, Finance Director Nancy Gross, Chief of Police Adam Zink, Director of Public Works James Gretencord, ESDA Director Dennis Housman, Deputy City Clerk Joie Ziller

Approve Previous Meeting Minutes

Aldersperson Jeffries made a motion and Aldersperson Kirwin seconded to approve the December 12, 2023 meeting minutes and have them placed on file. Upon the voice vote, 8 yes. The motion carried.

Public Comment

No public comments were made.

Mayor's Report

Mayor Dietz informed the Committee that the debris in the Launching Pad parking lot was cleared by the Public Works Department and the owner was cited.

Administrator's Report

Administrator Smith reminded us of the City Comprehensive Plan and Master Parks Plan Public Open House #1 being held on January 31, 2024, from 6 PM to 8 PM at the Wilmington High School.

Police & ESDA

Co-Chairs Alderspersons Mietzner & Allred

Chief of Police Monthly Summary Report

Chief Zink briefed the Committee on the happenings within the department and addressed his report that was included with the agenda packet.

Director of ESDA Monthly Summary Report

The Committee reviewed the ESDA Report as prepared by Director Housman. No further discussion was had regarding the report.

Other Pertinent Information

No other pertinent information was discussed.

Ordinance & License Committee

Co-Chairs Alderpersons Kirwin & Knight

Other Pertinent Information

Administrator Smith stated that an ordinance amending the regulations of unscheduled intercity buses will be included on the January 16, 2024, City Council agenda.

Buildings, Grounds, Parks, Health & Safety Committee

Co-Chairs Alderpersons Jeffries & Smith

Other Pertinent Information

No other pertinent information was discussed.

Water, Sewer, Streets and Alleys Committee

Co-Chairs Alderpersons Vice & Holmes

Director of Public Works Monthly Summary Report

The Committee reviewed Director Gretencord's monthly report included in the agenda packet.

Discussion - Prairie Farms Project Specifically Concerning Stormwater

Roy Surdej expressed his concerns about the stormwater management issues in the Prairie Farms subdivision and the need for comprehensive planning to address the longstanding issue of water retention in the developed area. Mr. Surdej requested that the City not issue any additional building permits until the stormwater management issue is resolved.

Review and Provide Direction on the Next Step of the Kankakee Street Bridge Rehabilitation Project

Howard Hamilton, representing Environmental Design International, Inc. briefed the Committee on the Kankakee Street bridge project with the request for direction on the options related to the Historic Preservation Report. The Committee was in favor of contracting directly with TranSystems to complete the rehabilitation option of the Historic Preservation Report due to the rarity of this type of bridge in Illinois.

Review and Provide Direction to Proceed with FY25 MFT Project Scope as Planned

The Committee reviewed Director Gretencord's memo included in the agenda packet. Alderperson Mietzner expressed his concerns regarding the road condition on Sunset Drive, Lindy Lane, and Wilda Avenue and requested a plan to address those roads. The Committee was in favor of following the proposed outline related to FY25 Motor Fuel Tax Road Program.

Consideration to Approve the Request to Seek Utility Easement on Wilmington School District Property to Loop the Water Main from Laurel Avenue to Lexington Court

The Committee reviewed Director Gretencord's memo related to the proposed watermain loop. After a brief discussion, the Committee agreed to allow the Public Works Director to seek a utility easement on Wilmington School District property to loop the water main from Laurel Avenue to Lexington Court.

Consideration to Approve the Quote from Automatic Control Service to Upgrade the PLC and Install Cellular Communication to the South Arsenal Road Booster for \$12,635

The Committee reviewed and discussed the SCADA cellular upgrade and agreed that this purchase request be placed on the January 16, 2024, City Council consent agenda for full approval.

Consideration to Approved the Quote from Lindblad Construction Company to Construct and Install Track and Industrial Curtain Around the Lime Feed Equipment for \$13,025

The Committee reviewed and discussed the quote for an equipment upgrade at the Water Plant and agreed that this purchase request be placed on the January 16, 2024, City Council consent agenda for full approval.

Review and Provide Direction to the Repairs Needed to the West Lime Lagoon Casing and Catwalks

The Committee reviewed Director Gretencord's memo related to repair needs associated with Water Treatment Plant lime lagoons. Following a brief discussion, the Committee agreed that we request Chamlin & Associates create plans to replace the lime lagoon casing equipment and catwalks so we can put this project out for bid.

Review and Provide Direction to the Street Sweeping Program

The Committee reviewed the memo as presented in the agenda packet. The Committee directed Director Gretencord to prepare the necessary bid for contracted services for street sweeping and to not, at this time, surplus the City's current street sweeper.

Other Pertinent Information

No other pertinent information was discussed.

Personnel & Collective Bargaining Committee

Co-Chairs Alderpersons Mietzner & Holmes

Other Pertinent Information

Administrator Smith advised the Committee that she will provide an update to the MAP grievance related to uniform allowance and the AFSCME collective bargaining agreement at the January 19, 2024, Council meeting during the executive session.

Adjournment

The motion to adjourn the meeting was made by Alderperson Holmes and seconded by Alderperson Mietzner. **Upon the voice vote, the motion carried.** The Committee of the Whole Meeting held on January 9, 2024, adjourned at 6:53 p.m.

Respectfully submitted,

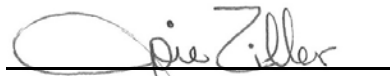

Joie Ziller, Deputy City Clerk



MEMO

Date: February 8, 2024

To: Honorable Mayor Dietz and City Council Members

From: Jeannine Smith, City Administrator 

Cc: Joie Ziller, Deputy Clerk

Re: January 2024 Building Department Report

Please find following a brief synopsis of building department activities for the January 2024.

Permit #	Date	Owner / Applicant	Project Address	Description	Value	Fee	Inspe Req	Type	X	Contractor	
				Jan-23							
WI-24-001	1/2/2024	BERKOTS	692-700 BALTIMORE	STORE REMODEL	\$ 296,000.00	\$ 3,480.00	VARIOUS	CRC	X	ACE MECHANICAL SVC	
WI-24-002	APPLIED	CALDERON	616 DANIELS	SOLAR ROOF	\$ 85,909.01	\$ 865.75	FE-FN	OW		LGCY INSTALLATION SERVICES	
WI-24-003	1/5/2024	MAHALIK	815 LEXINGTON	INGROUND POOL	\$ 95,400.00	\$ 1,575.00	VARIOUS	POL	X	AQUA POOLS INC.	
WI-24-004	APPLIED	LOVES TRAVEL STOP	21624 W ALEXANDER	NEW COMMERCIAL	\$ 4,000,000.00		VARIOUS	CNC		TBD	
WI-24-005	INVOICED	PAREEK	107 & 109 BRIDGE	FLOOD RESTORATION	\$ -	\$ 50.00	CONSULTATION	OW		B&F CODE CONSTRUCTION SERVICES	
WI-24-006	1/25/2024	KALAFUT	616 DANIELS	REROOF	\$ 9,000.00	\$ 225.00	WI-FN	RFR	X	OMEGA CONTRACTING LLC	
WI-24-007	1/30/2024	APERION	555 W KAHLER	SEWER REPAIR/CLEANOUT	\$ 4,621.34	\$ 148.50	FP	OW	X	ROTO-ROOTER	
					\$ 4,490,930.35	\$ 6,344.25					

January 2024 Inspection Report

PERMIT#	ADDRESS	INSPECTION DATE	PASS/FAIL	INSPECTION TYPE
WI-23-115	1441 TOMMY	1/15/24	P	INSULATION
WI-23-194	30701 HARVEST DR	1/3/24	P	FOUNDATION BACKFILL
WI-23-195	30719 HARVEST DR	1/4/24	P	FOOTING
WI-23-195	30719 HARVEST DR	1/8/24	P	FOUNDATION
WI-23-221	30350 GRASKAMP	1/15/24	P	FINAL BUILDING
WI-23-227	30260 GRASKAMP	1/9/24	P	FINAL BUILDING
WI-23-262	700 BALTIMORE	1/17/24	P	DEMO FINAL
WI-23-266	21538 TRICK CIRCLE	1/4/24	P	FENCE POST ROUGH
WI-23-266	21538 TRICK CIRCLE	1/10/24	P	FENCE FINAL
WI-23-267	1095 S WATER STE D	1/25/24	P	FINAL ELECTRIC
WI-23-267	1095 S WATER STE D	1/26/24	P	FINAL MECHANICAL
WI-23-267	1095 S WATER STE D	1/27/24	P	FINAL BUILDING
WI-22-134	923 WINCHESTER GREEN	1/10/24	F	FINAL BUILDING
WI-22-134	923 WINCHESTER GREEN	1/10/24	F	FINAL MECHANICAL
WI-22-134	923 WINCHESTER GREEN	1/10/24	F	FINAL ELECTRIC
WI-22-134	923 WINCHESTER GREEN	1/11/24	P	FINAL BUILDING
WI-22-134	923 WINCHESTER GREEN	1/11/24	P	FINAL MECHANICAL
WI-22-134	923 WINCHESTER GREEN	1/11/24	P	FINAL ELECTRIC
WI-22-134	923 WINCHESTER GREEN	1/11/24	P	FINAL PLUMBING
WI-24-005	107-109 BRIDGE ST	1/29/24	P	FLOOD CONSULTATION



City of Wilmington Police Department

Departmental Memorandum

To: Honorable Mayor Dietz and City Council
From: Chief Adam Zink
Subject: Monthly Status Report – January 2024

During the month the patrol division had the following activity:

- 13 Pedestrian/Suspicious Stops were conducted
- 259 Business (Walk and Talk) Checks (officers entering businesses during normal hours)
- 10526 Premise Checks (officer checking cursory checks of businesses after hours)
- 3 misdemeanor and/or warrant arrests
- 0 felony arrests
- 88 written traffic citations
- 80 written traffic warnings
- 5 compliance/parking (local ordinance) tickets
- Officers handled an additional 569 calls for service and wrote 57 related reports.
- 8 trucks were weighed based on a suspicion of being overweight and fined accordingly

Investigations Division had the following activity:

- Closed (14) cases: 10 administratively, 2 no-complaint, 1 referred, 1 uncooperative victim
- Added (6) new cases; continued background investigations for new hires

Training:

- (8) officers received firearm training on 3 training days – 24 drills completed.
- Each officer participated in 2 Lexipol daily training scenarios.
- All members have completed one PLI online training course (approximately two hours in length) on the topic of “Racial Profiling, Implicit Bias, and Cultural Competency”
- Several important certifications this month, including: one officer certified as Breath Alcohol Operator, and 3 officers certified as Juvenile Specialists.

Administration:

- Hiring process continues; background investigations in progress for part time officer, lateral hire, and final candidates on the standard hiring list
- Accreditation: process continues, mock evaluation is underway through ILEAP
- Employee evaluations completed for all Police Officers and Sergeants.
- River flooding situation required a lot of time, meetings, etc.
- Met with Tri-County Auto Theft task force to discuss options for joining the team
- Another officer was trained and certified as our newest Field Training Officer (FTO)

Truck Enforcement

WILMINGTON PD TRUCK REPORT: JANUARY 2024

<u>DATE</u>	<u>VIOLATION</u>	<u>LBS EXCESS</u>	<u>FINE/ BOND</u>	<u>TRAFFIC</u>	<u>LOCATION</u>	<u>CITATION</u>	<u>OFFICER</u>
				<u>ASSESSMENT</u>		<u>TYPE</u>	
1/3/2024	OW - Registration	10,320	\$590	\$260	Rt 53/Peotone Rd	UTC	Rourke 109
1/3/2024	OW - Registration	21,650	\$590	\$260	N Water St/Baltimore St	UTC	Soucie 118
1/5/2024	OW - Gross	6,780	\$2,100	\$260	Stripmine Rd/Davy Ln	UTC	Rourke 109
1/5/2024	OW - Gross	2,780	\$330	\$260	New River Rd/Boathouse Rd	UTC	Rourke 109
1/17/2024	OW - Registration	15,480	\$342	\$260	Rt 53/New River Rd	UTC	Rourke 109
1/31/2024	OW - Gross	40,200	\$12,150	\$260	Lorenzo Rd/Graaskamp Blvd	UTC	Rourke 109
1/31/2024	OW - Bridge	4,200	\$850	\$260	New River Rd/Rt 53	UTC	Rourke 109
1/31/2024	OW - Gross	11,840	\$3,600	\$260	Lorenzo Rd/Graaskamp Blvd	UTC	Rourke 109
TOTAL			\$20,552				

Code Enforcement

Joey Crist
Code Enforcement
January 2024

NEW Work orders created – 17

COMPLETED Work orders – (some work orders have more than one issue)

IPMC (Property Maintenance) - 1

Garbage / debris – 3

Disabled Vehicle complaint – 1

Parking complaint – 2

Assist to City Hall – 2

Assist City Crew - 2

Golf Cart / Safety Inspection – 6

Citizen Assist / Information - 1

IN PROGRESS Work orders – 2

WO 2465 – 215 N Mitchell St. – Parking Complaint. Was given until end of January 2024 to get plates updated and find a place for bigger truck. (As of 02/02/24, vehicle and trailer have been removed)

WO 2446 – 611 E County Rd –Last letter sent 12/07/23 with reference to the vehicles. (Update: 02/02/24, spoke with homeowner. Given until 02/05/24. If vehicle and boat are not moved, 2nd offense citations – progressive fines \$250 – will be issued.

ON HOLD Work Orders – 6

WO 2446 – 1103 N Kankakee St – No siding.

WO 2445 – 520 E Baltimore St – No siding.

WO 2256 – 101 N McIntyre St – Garage falling down

WO 1982 – 214 Bridge St – Fence in disrepair. Eviction in progress.

WO 1721 – 202 S Water St – Property Maintenance complaint.

WO 1244 – 216 N First St – Gravel in residential zoned area.

It should be noted, WO's in HOLD Status have been forwarded to Building Inspector for further review.

Illinois gives regional task force \$1.8 million to combat vehicle thefts

By [Felix Sarver](#)



Secretary of State Alexi Giannoulias is pictured in a file photo. (Andrew Adams)

August 27, 2023 at 6:00 am CDT

The Tri-County Auto Theft Task Force has received \$1.8 million in state funding to continue its efforts to combat vehicle thefts and other related crime in Will, Grundy, Kendall, Kankakee and Iroquois counties.

The funding is part of a larger initiative from Illinois Secretary of State Alexi Giannoulias' office to address vehicle thefts across the state, according to a report from Capital News Illinois. Other interagency law enforcement task forces similar to the Tri-County Auto Theft Task Force also have received funding.

Between July 2019 and June of this year, the Tri-County Auto Theft Task Force made more than 300 arrests and recovered more than 1,000 vehicles worth more than \$20 million, in addition to recovering more than \$800,000 in stolen cargo, said Joliet police Sgt. Ed Grizzle, who serves as director of the task force.

The task force has 12 officers from various police agencies, two prosecutors from two different counties and a civilian staff member, Grizzle said. The officers assigned are undercover detectives, he said.

“The task force is a covert unit that handles all matters regarding vehicle crimes – vehicular hijacking, stolen cars, title fraud, financial identity theft, cargo theft, catalytic converter theft to name a few,” Grizzle said.

The task force also assists other police agencies in other crimes they are investigating to find a suspect vehicle, Grizzle said. It also teaches new police officers about vehicle-related crimes, he said.

The task force makes presentations to community groups, high schools, and colleges and universities, Grizzle said.

“The task force will continue to combat crimes in the areas of auto theft and continue to work with all police agencies – federal, state, county and local – to continue to make our communities safer,” he said.

The task force has a 74% recovery rate of stolen vehicles and works closely with insurance companies and the National Insurance Crime Bureau, Grizzle said.

Tri-County Auto Theft Task Force



TCAT 2023 Year End Stats 1/1/23 – 12/31/23

564 - Cases opened

484– MVT, Carjacking or trailer thefts with 351 Recoveries 73%

Recovery value \$9.3 million

44 - Catalytic Converter Investigation

10 - Cargo Theft Investigations \$682k in recoveries

25 - Special Details

Total in Recoveries MV and Non MV \$9.9 million

130 Arrests, 110 Felonies, 20 Misdemeanors

Presentations at Kankakee Community College, Olivet Nazarene University, Kankakee Area Career Center. Joliet neighbor meetings, New hire training at Joliet PD.

Trends – Still Kia and Hyundai's, SRT products (swaps), increase in Chevy Camaros and Corvette (re-program thefts).

Insurance Company top recoveries

62-State Farm 7 – All State 3 – Travelers

27- Progressive 6 – USAA 85 – Uninsured or unknown

18-GEICO 5 – Farmers

TRI-COUNTY AUTO THEFT UNIT

The Tri-County Auto Theft Task Force Unit was created by State legislature and imposes a fee for every auto insurance policy which is written on a car registered in the state. The funds are used to finance the efforts of a number of Illinois Task Forces organized to locate and prosecute auto theft cases.

The Tri-County Unit operates in Will, Grundy, and Kankakee Counties and is comprised of police officers from a number of police departments operating in the three-county area. The fund provides partial payment of the annual salary of an Assistant State's Attorney whose services are dedicated to the prosecution of auto theft-related cases.

The Task Force's goal is to find stolen vehicles and to root out organized auto theft rings. The efforts of the Task Force have prevented organized auto theft rings from being a significant problem in Will County and have stopped the proliferation of large scale chop shops.

By devoting one experienced felony prosecutor to handle daily court calls, process the vertical prosecution of the auto theft case from investigation to verdict, and develop cases for future prosecution, as well as the State's Attorney's Office executing search warrants and the use of judicially authorized eavesdrops, the State's Attorney's Office plays a meaningful role in the prevention of auto thefts in Will County and the Tri-County area.

Resolution No. 2024-01

RESOLUTION TO DISPOSE OF SURPLUS PROPERTY

WHEREAS, 65 ILCS 5/11-76-4 provides for the methodology to dispose of certain municipal property which is no longer necessary or useful to the city; and

WHEREAS, the City Council of the City of Wilmington has determined that the City of Wilmington no longer needs the items of personal property on the attached Exhibit A, and such items are surplus property.

THEREFORE, BE IT RESOLVED, that the City Council declares that the items on the attached Exhibit to be surplus property; and

BE IT FURTHER RESOLVED that if the cost of disposal, sale, and transportation of the items is more than they are worth, then the items are declared worthless and may be junked or demolished.

BE IT FURTHER RESOLVED that the surplus property may be transferred to another governmental agency or unit pursuant to Illinois statutes.

NOW THEREFORE BE IT RESOLVED that the Chief of Police is hereby authorized to dispose of property identified in Exhibit A in a manner consistent with Illinois law as set forth above.

ADOPTED this ____ day of _____ 2024 with ____ members voting aye, 0 members voting nay, the Mayor voting N/A, with 0 members abstaining or passing and said vote being:

Ryan Jeffries	_____	Kevin Kirwin	_____
Ryan Knight	_____	Dennis Vice	_____
Jonathan Mietzner	_____	Leslie Allred	_____
Thomas Smith	_____	Todd Holmes	_____

Approved this ____ day of _____ 2024

Ben Dietz, Mayor

Attest:

Joie Ziller, Deputy City Clerk

Exhibit A

**Surplus Sheet
City of Wilmington**

Date: 02/13/2024
Name: City of Wilmington
Address: 1165 S. Water Street
Wilmington, IL 60481

Description	Unit Value	Value
2015 Ford Explorer (VIN 1FM5K8AR1FGB62064)	N/A	N/A

Kankakee River Ice Jams and Flooding 1-15-24 thru 2-3-24

1-15-24:

ESDA was notified by citizen of ice jam had formed upstream of Bardwell Island in the Conservation Area.

Upon reconning the area ice had formed from the mouth of the Kankakee River from Desplaines River to the BNSF railroad trestle.

Large amounts of frazil ice had developed due to subzero temperatures.

Water had surrounded a few homes in Phelan Acres and on Cottage Road.

Monitor area along Will County EMA.

Police & Fire had been notified of the situation.

17:51 HRS. Fire & ESDA was toned out via Wescom for a citizen needing assistance leaving his residence on Kelly Lane as water about 3ft. in depth had rising around his resident.

Water teams floated an inflatable boat to the resident on brought victim to safety.

Air Temps: High 2, Low -10

1-16-24

ESDA along with Will County EMA continued to monitor the jam to had made it way upstream to the Readman Lane area near I-55.

Meeting was called to access the situation at Wilmington EOC.

Attendees:

Will County EMA: Alison Anderson, Brian Czion, Erin Ward, Tom Murray

Wilmington Fire: DC Friddle

Wilmington Police: Zink, Doyle

Wilmington ESDA: Housman, Princko

Representative from National Weather Service

Notifications were sent out to agencies that may be affected by the jam and potential flooding.

Will County EMA handled the notifications.

Continued to monitor river until nightfall.

By end of day the jam was just upstream of Readman Lane. Large amounts of frazil ice were still coming down stream.

Air Temps: High 3, Low -7

1-17-24

By morning on the 17th the ice jam reaches the Wilmington Dam. Water was running through the North and South Island parks.

At approximately 6:00 a.m. Wilmington Police closed the parks.

10:00 A.M. Open Wilmington EOC.

Meeting with city and county officials.

Wilmington ESDA: Director Housman, Deputy Director Princko

Wilmington PD: Chief Zink, Deputy Director Doyle

City: Mayor Deitz, Administrator Smith, Public Work Gretencord

Wilmington Fire: Chief Zlomie, Deputy Chief Friddle

Wilmington Schools: Keven Feeny

Will County EMA: Director Anderson,

Worked on establishing a plan. (IAP) for upcoming days.

One syphon pipe was open on Cottage Road to start trying to open channel.

County EMA working on getting permission to open all three pipes.

Wilmington PD place notices on residents and businesses on North & South Island advising to be alert for fast changing conditions and possible flooding.

ESDA, PD, FD continued to monitor river.

Air Temp: High 20, Low 2

1-18-24

Ice jam has not changed but river water levels have begun to recede.

Will County & City of Wilmington have declared a Disaster Declaration in order to get two more pipes opened.

ESDA, Will County monitoring river from DesPlaines River to City of Kankakee.

At 9:11 am, received word from Director Anderson that they received permission to have all three pipes open.

Pipes were opened at approximately noon.

ESDA and County continued to monitor river until night fall.

Air Temp: High 14, Low 5

1-19-24

More frigid weather had move back in the area freezing what channels that had developed the prior two days.

Wilmington ESDA and County EMA continued monitoring till nightfall.

Air Temp: High 14 Low 5

1-20-24

Ice jam has reached Lakewood Shores area.

Continue monitoring.

At approximately 2:00 pm, Drone fly over, City of Wilmington, & Phelan Acres.

Continue Monitoring till night fall. No change in jam status.

Air Temp: High 18, Low 4

1-21-24

Wilmington ESDA and Will County flew drone missions.

Wilmington flew in the city, dam area and water treatment plant area.

A jam has formed on Turtle Island, keeping ice levels high upstream to dam.

County flew in Cottage Road area, noted that siphon pipes have open channel along river left shoreline downstream to near Bardwell Island.

Continued to monitor till nightfall.

Air Temp: High 21, Low 1

1-22-24

Conditions on river have not changed.

10:00 a.m.

EOC meeting was held to update.

Continued monitoring.

Temperatures have been rising into the 30's.

Air Temp: High 35, Low 33

1-23-24

Conditions on river have not changed. Weather has warm up, but rain, freezing rain, and fog has dominated the area.

Channel from syphon pipes have move downstream toward Will Road Bridge passing Bardwell Island. Seem to be craving out channel on North & South Sides of island.

Continuing monitoring.

Air Temp: High 39/ Low 30

1-24-24

Temperatures rising during the day. Light Rain & Drizzle

River water levels slowly rising.

Continued monitoring river.

Air Temp: High 38/Low 34

1-25-24

Water levels rising.

Approximately 08:00 Hours

Will EMA Director Anderson meet with ESDA Housman & Princko at the dam.

Anderson contacted National Weather Service advising of changes. Requested a flood warning be issued for the area.

09:29 Hours National Weather Service issues a Flash Flood Warning for the area effective

1-25-24- 09:29 Hrs. till 09:15- 1-27-24.

Will County EMA volunteers were called out to monitor river:

Observation Points: Lakewood Shores, Dam, Water Treatment Plant, River Road in Conservation Entrance east of Interstate 55. Cottage Road & Phelan Acres area.

Monitored river till nightfall.

16:00 Hrs. News conference was held at City Hall.

23:09 Hrs.

Housman received a phone call from the Wilmington Police Duty Officer, stating that the river was running at a high rate of speed about 4 feet deep over Route 53 (Baltimore St.) on the Island.

Wilmington Fire, Wilmington ESDA, Wilmington Police, Mabas 15 Water Team was dispatched to scene.

All structures on Island were search for victims. 14 people was evacuated from the Super Shine Motel (formerly the VanDuyne Motel).

Route 53 was shut down between Water/Rt 102 & Baltimore/Rt. 53 & Baltimore/53& 1st Street.

Also had units at Baltimore/Rt.53 & Strip Mine Rd. to divert semi- trucks to strip Mine Road.

Will County's Command Truck was deployed to City Parking lot across from ESDA station to be used as Command post.

Occupied by City Police, Fire, ESDA, Mayor, Will County EMA, Mabas 15 Water team Will County PIO., Wilmington School District.

Moose Lodge was opened as a shelter.

Continuing monitoring situation.

Air Temps: High 38/Low 35

1-26-24

Continuing Monitoring situation.

Barricades were placed at Rt 53 & River RD., Kankakee St. River RD., Boathouse Rd & River RD.

I-55 and River Rd. in case it would be necessary to shut River Rd. due to flooding.

At approximately 11:30 a.m. Water levels across Rt 53 dropped quickly.

At 12:14 Rt 53 was opened.

Continued Monitoring

15:00 hrs. County Command Vehicle was shut down.

Approximately 19:00 Hrs. reports of River Road was flooding just east of I-55., possible ice being push onto the I -55 Bridge over the river.

Wilmington Police & Fire responded. Only a small chunk of ice ended up on the bridge causing no problems. River Road did have ice in roadway. The area had a rapid rise in the area pushing water and ice onto roadway. Jam on river broke up and water had receded leaving ice on roadway.

Wilmington ESDA closed River Rd. until Will County High Department cleared the ice from roadway. Roadway was opened at approximately 19:00 Hrs.

Air Temps: High 40/ Low 37

1-27-24

Survey Island Parks for damage. Heavy damage was found on the North Island.

Only moderate damage on the South Island.

Air Temps: High 41/Low 36

1-28-24

Drone flight over North & South Island Parks surveying damage.

1-30-24

After flood meeting with County and City officials.

2-1-24

ESDA members debriefing meeting.

2-3-24

Assisted Will County EMA with damage assessment.

Area surveyed: Downtown Wilmington, North & South Island, Towpath Lane,

Kankakee River Drive, Kelly & Phillips Road, North & South Redman Lane.

Agencies involved with the 1-15-24 thru 2-3-24 Ice Jam/River Flooding Event

City of Wilmington

Administration Staff

Police

ESDA

Public Works

Water Department

Fire District

Will County EMA

Administration Staff

Volunteers

MABAS 15 Water Rescue Team

Will County Municipal EMA's

Braidwood ESDA

Manhattan EMA

Monee EMA

Channahon EMA

Homer Glenn EMA

New Lenox EMA

Will County Public Information Officer

Will County Department of Transportation

Will County Sheriff Department

Illinois State Police

Illinois Department of Transportation

Civil Air Patrol

Salvation Army

American Red Cross

Will County Center for Community Concerns

Kankakee River Ice Jam/ Flooding Event

January 15th 2024 thru February 3th 2024

Wilmington ESDA Members Hours

Dennis Housman		HOURS
1-15-24	Monitoring Jam/Water Call	10
1-16-24	Flood Meeting /Monitor Jam	10
1-17-24	Flood Meeting/Monitor Jam	10
1-18-24	Monitor Jam	10
1-19-24	Monitor Jam	10
1-20-24	Monitor Jam	8
1-21-24	Monitor Jam/ Drone Flyover	10
1-22-24	Flood Meeting/ Monitor jam	8
1-23-24	Monitor Jam	10
1-24-24	Monitor Jam	10
1-25-24	Flood Meeting/City Flooding Response	14
1-26-24	City Flooding Response/Road Closure	20
1-27-24	Damage Assessment/ Equipment Clean Up	8
1-29-24	Documentation	6
1-30-24	Flood Meeting	3
2-1-24	Debriefing Meeting ESDA Members	2
2-3-24	Assist County with Damage Assessment	<u>7</u>

Total: 156 Hours

Rich Princko**HOURS**

1-15-24	Monitor Jam/Water Call	10
1-16-24	Flood Meeting/Monitor Jam	5
1-17-24	Flood Meeting/ Monitor Jam	8
1-18-24	Monitor jam	3
1-21-24	Monitor Jam	3
1-22-24	Flood Meeting/ Monitor Jam	10
1-23-24	Monitor Jam	10
1-24-24	Monitor Jam	5
1-25-24	Flood Meeting/ City Flooding Response	14
1-26-24	City Flooding Response/ Road Closures	20
1-30-24	Flood Meeting	3
2-1-24	Debriefing Meeting ESDA Members	<u>2</u>

Total: 93 Hours**Steve Luhrsen**

1-15-24	Water Call	3
1-17-24	Monitor Jam	8
1-25-24	City Flooding Response	1
1-26-24	City Flooding Response	14
1-27-24	Barricade Pick up	<u>3</u>

Total: 29 Hours

Erin Ward

1-15-24	Water Call	3
1-20-24	Monitor Jam	7.5
1-21-24	Monitor Jam/ Drone Flyover	6
1-25-24	City Flooding Response	1
1-26-24	City Flooding Response	5.5
1-27-24	Damage assessment/Equipment Clean Up	1.5
2-1-24	Debriefing Meeting ESDA Member	<u>2</u>

Total: 26.5 Hours**Sarah Krohn**

1-25-24	City Flooding Response	1
1-26-24	City Flooding Response/ Road Closure	9
2-1-24	Debriefing Meeting ESDA Members	2
2-3-24	Assist County with Damage Assessment	<u>7</u>

Total: 19 Hours**Paul Hodolitz**

1-15-24	Water Call	3
1-16-24	Monitor Jam	2.5
1-17-24	Monitor Jam	8.5
1-18-24	Monitor Jam	3
1-25-24	City Flooding Response	1
1-26-24	City Flooding Response/ Road Closure	18
2-1-24	Debriefing Meeting ESDA Members	<u>2</u>

Total: 38 Hours

Wilma Stewart

2-1-24	Debriefing Meeting ESDA Members	2
2-3-24	Assist County with Damage Assessment	<u>7</u>

Total: 9 Hours

Barb Lardi

1-26-24	City Flooding Response/ Drone	8
2-1-24	Debriefing Meeting ESDA Members	<u>2</u>

Total: 10 Hours

Andrew Lucky

1-25-24	City Flooding Response	1
1-26-24	City Flooding Response/Road Closure	9
2-1-24	Debriefing Meeting ESDA Members	<u>2</u>

Total: 12 Hours

Kim Gotte

1-21-24	Monitor Jams/ Drone Flyover	4
1-26-24	City Flooding Response/ Drone Flyovers	7.5
1-28-24	Drone Flyover Damage Assessments	4
2-1-24	Debriefing Meeting ESDA Members	<u>2</u>

Total: 17.5

Wilmington ESDA Total: 410 hours



MEMO

Date: February 9, 2024

To: Honorable Mayor Dietz and City Council Members

From: Jeannine Smith, City Administrator

Cc: Joie Ziller, Deputy Clerk
Bryan Wellner, General Counsel
Department Directors

Re: Discussion Regarding Preliminary Plans for South Island Park Grant Project

Budget Impact: Grant Funded

History: Last summer, the City of Wilmington received notice of a grant award from the Department of Commerce and Economic Opportunity ("DCEO") in the amount of \$95,000 which is an appropriation from Representative DeLuca. The grant is a reappropriation of Build Illinois Bond Fund, the proceeds from which are to be used for capital improvements. The City of Wilmington is also in receipt of Rebuild Illinois ("RBI") funds equaling \$377,234.10. These funds need to be expended this year.

Staff Analysis: In September of 2023, Staff discussed potential uses for the grant with the City Council and advised that the funds which must be a bondable capital improvement provided that such expenditure purposes:

Are not recurring; are of a durable nature and not consumed in use; are not subject to inherent risk of failure, rapid technological obsolescence, or primarily intended to fulfill temporary requirements or needs; and appreciably increases, improves or enhances the interest of the State of Illinois, or its legally constituted subdivision, in the property, land, building or asset to be developed, constructed or improved.

Staff has identified two projects that would benefit from these funds; the first of which being the dam modification project and the second being the South Island Park project that was identified in the proposed island park development plan dated June, 2014 (see attached). As we will not be able to complete the dam modification project this year, our focus turned toward the realignment of the South Island entrance, parking lot structure, multi-use path and other amenities.

The estimated cost for completion of the plan drawn by Chamlin & Associates (see attached) is \$276,283.51. Using the \$95,000 from Representative DeLuca's appropriation will leave us with \$181,283.51 which may be drawn from the RBI fund balance.

Staff Request: Staff respectfully requests your consideration and feedback on the plans before you. We will need to formally submit the plans and the budget to the State for project approval and will be back before you for formal approval of invoices and bidding documents in the near future. At this time, we are requesting this item be placed on the agenda for preliminary plan approval and a motion to proceed with this project being funded with the DCEO and RBI funds.



ISLAND PARK SITE DEVELOPMENT PLAN



KEY

1. **EXISTING TRAIL, ROUTE CONNECTION**
EXISTING TRAIL, ROUTE CONNECTION FROM DOWNTOWN WILMINGTON TO THE FITNESS CENTER
2. **EXISTING CROSSING**
CROSSING OF HISTORIC ROUTE 66 AND BALTIMORE STREET AT THE PEDESTRIAN BRIDGE
3. **PROPOSED REGIONAL TRAIL**
PROPOSED TRAIL CONNECTION FROM BALTIMORE STREET TO THE FITNESS CENTER
4. **PROPOSED PARKING LOT**
PROPOSED PARKING LOT FOR VISITORS TO THE FITNESS CENTER AND TRAIL HEAD
5. **PROPOSED TRAIL HEAD & PICNIC AREA**
PROPOSED TRAIL HEAD AND PICNIC AREA
6. **PROPOSED NATIVE PLANT RESTORATION**
PROPOSED NATIVE PLANT RESTORATION PROJECT TO BE CONDUCTED IN THE FITNESS CENTER AREA
7. **PROPOSED ENTRANCE SIGN**
PROPOSED ENTRANCE SIGN TO THE FITNESS CENTER AND TRAIL HEAD
8. **PROPOSED KIOSK**
PROPOSED KIOSK FOR VISITORS TO THE FITNESS CENTER AND TRAIL HEAD
9. **PROPOSED INTERPRETIVE SIGNS**
PROPOSED INTERPRETIVE SIGNS TO BE PLACED AT THE FITNESS CENTER AND TRAIL HEAD
10. **BIKE RACKS**
PROPOSED BIKE RACKS FOR VISITORS TO THE FITNESS CENTER AND TRAIL HEAD
11. **FITNESS STATION AREA**
PROPOSED FITNESS STATION AREA AT THE FITNESS CENTER
12. **DRINKING FOUNTAIN**
PROPOSED DRINKING FOUNTAIN FOR VISITORS TO THE FITNESS CENTER AND TRAIL HEAD

INDEX OF SHEETS

1. COVER SHEET
2. GENERAL NOTES
3. SUMMARY OF QUANTITIES
4. TYPICAL SECTIONS
5. EXISTING CONDITION AND REMOVAL PLAN
6. PROPOSED GEOMETRY PLAN
7. PROPOSED GRADING PLAN

PROPOSED IMPROVEMENT PLANS

SOUTH ISLAND PARK ROAD IMPROVEMENTS CITY OF WILMINGTON WILL COUNTY

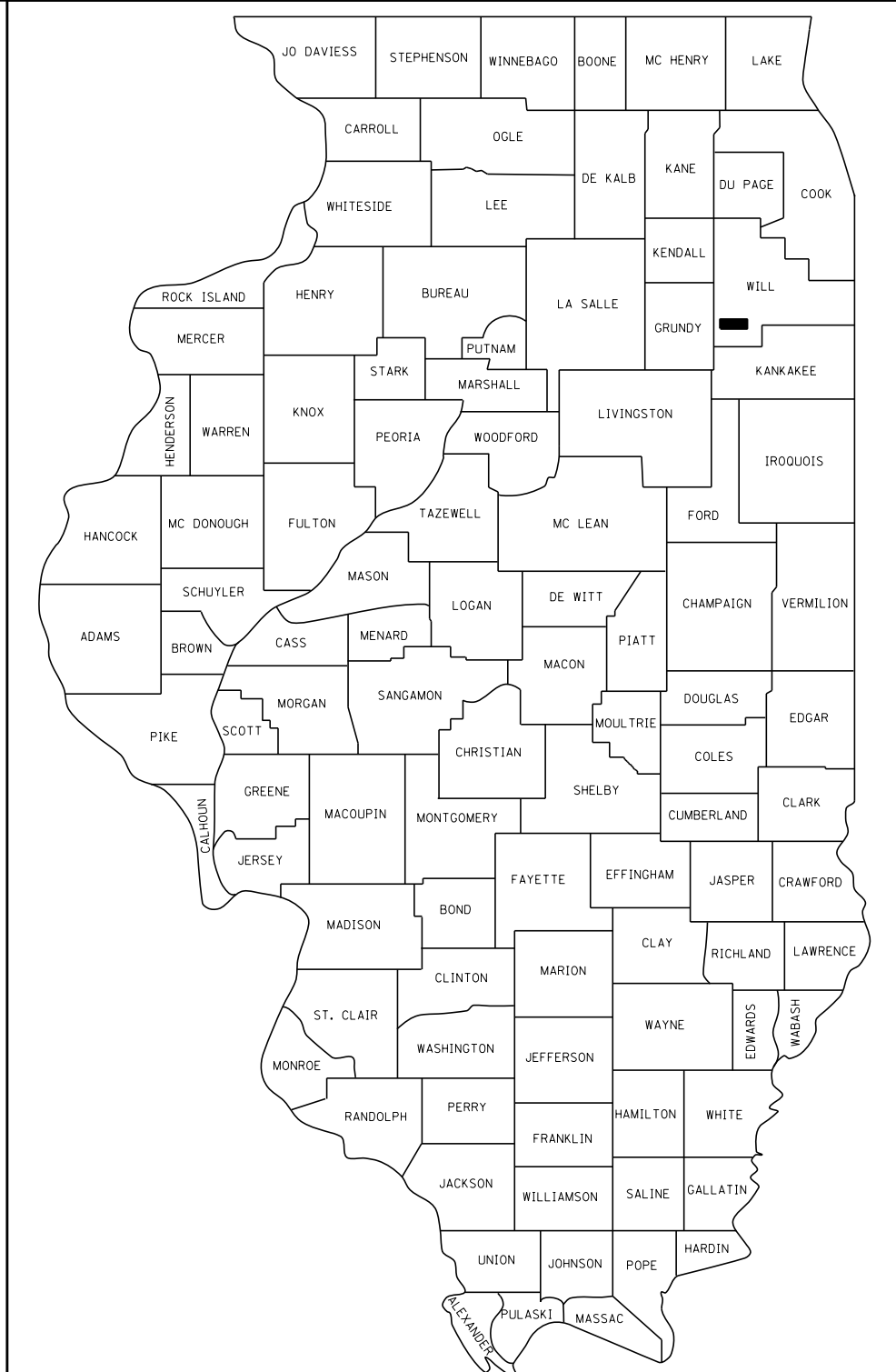

LOCATION OF SECTION INDICATED THUS: — ■ —

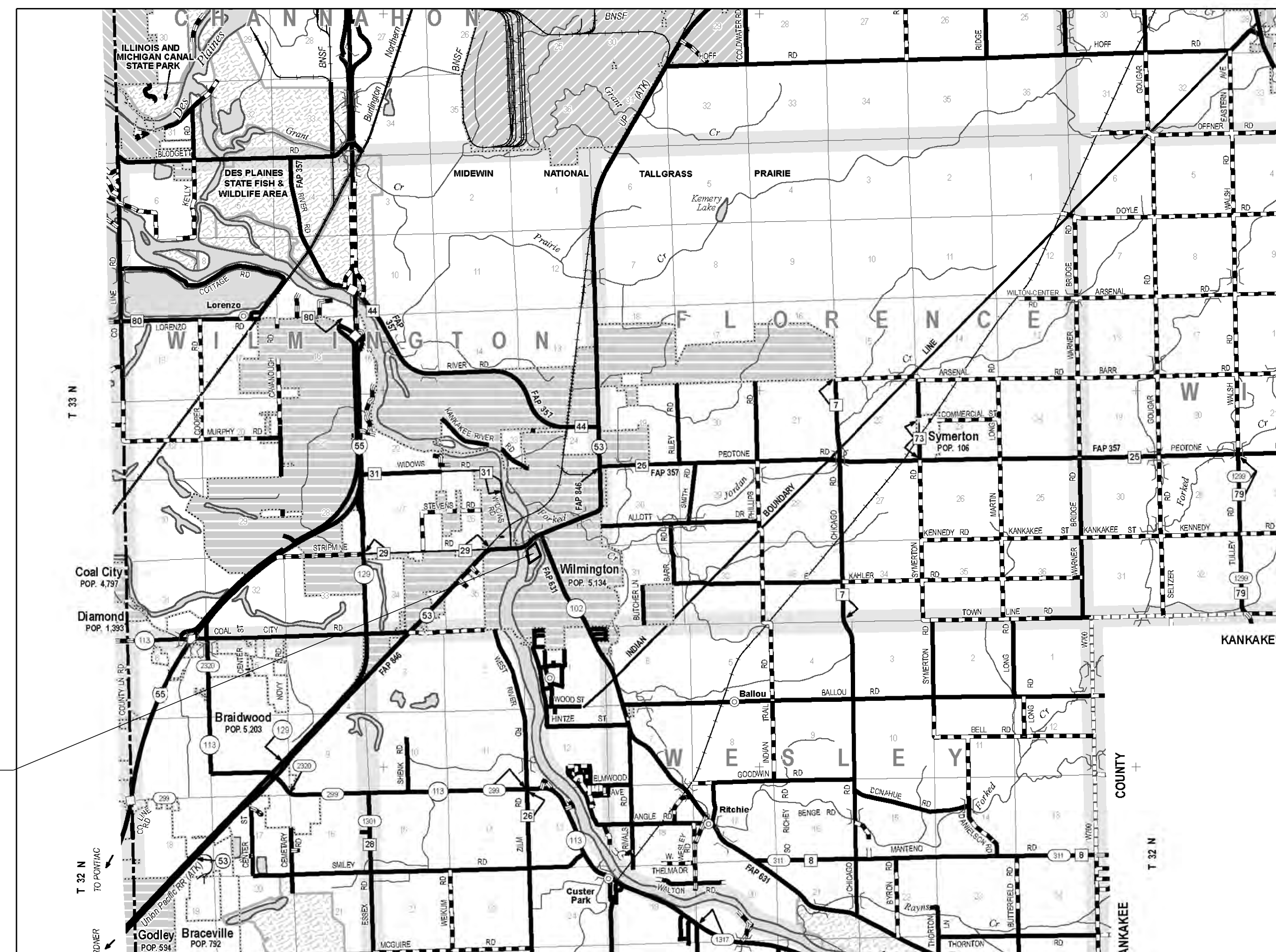

PROJECT LOCATION

SECTION 25, TOWNSHIP 33 NORTH, RANGE 9 EAST OF THE 3RD PRINCIPLE MERIDIAN

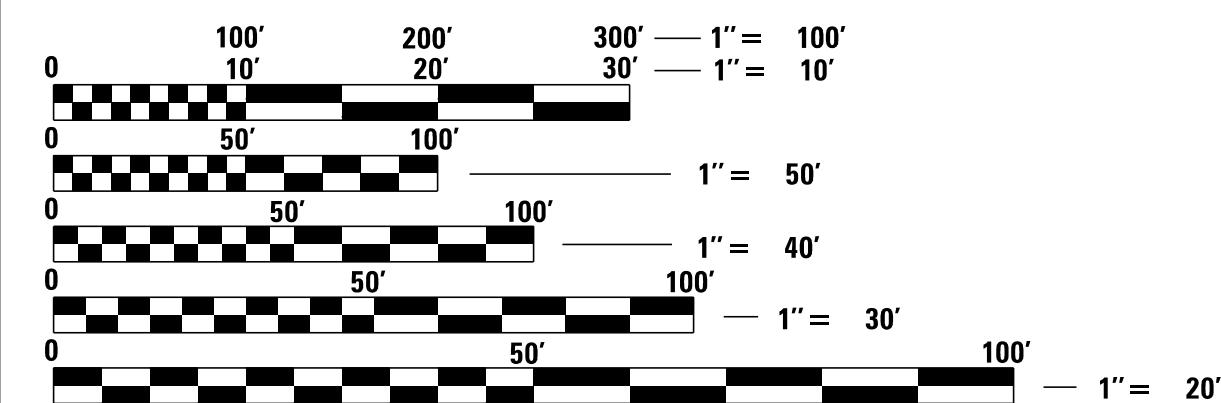

FULL SIZE PLANS HAVE BEEN PREPARED USING STANDARD ENGINEERING SCALES. REDUCED SIZED PLANS WILL NOT CONFORM TO STANDARD SCALES. IN MAKING MEASUREMENTS ON REDUCED PLANS, THE ABOVE SCALES MAY BE USED.

J.U.L.I.E.
JOINT UTILITY LOCATION INFORMATION FOR EXCAVATION
1-800-892-0123
OR 811

2/8/2024
date

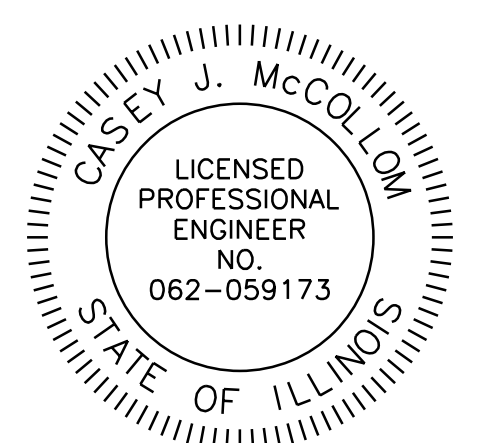

expires 11-30-2025

Casey J. McCollom
signature

PROFESSIONAL DESIGN FIRM
LICENSE NO. 184-001717

SPECIFICATIONS, STANDARDS AND SPECIAL PROVISIONS

ALL CONSTRUCTION SHALL BE DONE IN ACCORDANCE WITH THE "STANDARD SPECIFICATIONS FOR ROAD AND BRIDGE CONSTRUCTION", ADOPTED JANUARY 1, 2022; THE "SUPPLEMENTAL SPECIFICATIONS AND RECURRING SPECIAL PROVISIONS", ADOPTED JANUARY 1, 2024; THE LATEST EDITION OF THE "ILLINOIS MANUAL ON UNIFORM TRAFFIC CONTROL DEVICES FOR STREETS AND HIGHWAYS"(IMUTCD), "THE STANDARD SPECIFICATIONS FOR WATER AND SEWER MAIN CONSTRUCTION IN ILLINOIS" LATEST EDITION, THE "DETAILS" IN THE PLANS AND THE "SPECIAL PROVISIONS" INCLUDED IN THE CONTRACT DOCUMENTS.

ALL WORK SHALL BE PERFORMED IN ACCORDANCE WITH APPLICABLE LAWS AND GOVERNMENT AGENCY REGULATIONS AND RULES; AUTHORITIES HAVING JURISDICTION; OSHA REGULATIONS AND RULES; AND ANY APPLICABLE RULES AND REGULATIONS OF THE STATE OF ILLINOIS OR WILL COUNTY AGENCIES, FURTHERMORE, AND AS RELATED TO THE WORK, THE CONTRACTOR SHALL GIVE NOTICES AND COMPLY WITH APPLICABLE LAWS, ORDINANCES, RULES, REGULATIONS, AND LAWFUL ORDERS OF ALL PUBLIC AUTHORITIES BEARING ON THE SAFETY OF PERSONS OR PROPERTY OR THEIR PROTECTION FROM DAMAGE, INJURY OR LOSS.

ANY REFERENCE TO STANDARDS THROUGHOUT THE PLANS OR SPECIAL PROVISIONS SHALL BE INTERPRETED AS THE LATEST IDOT STANDARD.

ALL TRAFFIC CONTROL AND OTHER ADVISORY SIGNS NEEDED FOR CONSTRUCTION ARE TO BE FURNISHED BY THE CONTRACTOR IN ACCORDANCE WITH SECTION 700 OF THE STANDARD SPECIFICATIONS.

UTILITIES

THE CONTRACTOR SHALL COOPERATE WITH THE CITY IN ANY UNDERGROUND UTILITY CONSTRUCTION WHICH THE CITY MAY WANT TO PLACE DURING THE CONTRACTOR'S OPERATIONS.

THE CONTRACTOR SHALL BE RESPONSIBLE FOR CONTACTING THE OWNER OF ALL EXISTING FACILITIES SO THAT THE UTILITIES AND THEIR APPURTENANCES MAY BE LOCATED AND ADJUSTED OR MOVED, IF NECESSARY, PRIOR TO THE START OF CONSTRUCTION OPERATIONS. THE CONTRACTOR SHALL COOPERATE WITH ALL UTILITY OWNERS AS PROVIDED FOR IN THE STANDARD SPECIFICATIONS.

THE LOCATIONS OF EXISTING DRAINAGE STRUCTURES, STORM AND SANITARY SEWERS, WATER SERVICE LINES AND OTHER UTILITY LINES ARE APPROXIMATE, AND THE CITY DOES NOT GUARANTEE THEIR ACCURACY. THEIR EXACT HORIZONTAL AND VERTICAL LOCATIONS ARE TO BE DETERMINED IN THE FIELD BY THE CONTRACTOR AT HIS OWN EXPENSE.

THE CONTRACTOR SHALL BE RESPONSIBLE FOR THE PROTECTION OF ALL UNDERGROUND OR SURFACE UTILITIES EVEN THOUGH THEY MAY NOT BE SHOWN ON THE PLANS. ANY UTILITY THAT IS DAMAGED DURING CONSTRUCTION SHALL BE REPAIRED OR REPLACED TO THE SATISFACTION OF THE ENGINEER OR THE CITY. THIS WORK SHALL BE AT THE CONTRACTORS EXPENSE.

COORDINATION OF ALL UTILITY WORK INVOLVED IN THE CONSTRUCTION AREA WILL BE DISCUSSED AT THE PRECONSTRUCTION CONFERENCE.

BEFORE STARTING ANY EXCAVATION, THE CONTRACTOR SHALL CALL "JULIE" AT 800-892-0123 FOR FIELD LOCATIONS OF BURIED ELECTRIC, TELEPHONE, GAS AND CABLE TELEVISION FACILITIES. (48 HOURS NOTIFICATION IS REQUIRED.)

STAKING

THE CONTRACTOR SHALL PROTECT AND CAREFULLY PRESERVE ALL SECTION OR SUBSECTION MONUMENTS OR PROPERTY OR REFERENCE MARKERS UNTIL THE CITY, HIS AGENT OR AN AUTHORIZED SURVEYOR HAS WITNESSED OR OTHERWISE REFERENCED THEIR LOCATIONS.

ALL RADII FOR PROPOSED CURB AND GUTTER ARE TO THE EDGE OF PAVEMENT UNLESS OTHERWISE NOTED, AND SHALL BE AS INDICATED ON THE PLANS, ELEVATIONS SHOWN AT POINT OF CURVE, ETC. IS EDGE OF PAVEMENT UNLESS OTHERWISE NOTED.

ALL OFFSET LOCATIONS GIVEN ON THE DETAILED PLANS FOR STRUCTURES, ETC., ARE FROM THE PROPOSED BASE LINE OF CONSTRUCTION.

MISCELLANEOUS

ACCESS: THE CONTRACTOR SHALL PROVIDE ACCESS TO ABUTTING PROPERTY AT ALL TIMES DURING THE CONSTRUCTION OF THIS PROJECT, EXCEPT FOR PERIODS OF SHORT DURATION. THE COST TO PROVIDE ACCESS SHALL BE PAID FOR AS TEMPORARY ACCESS (PRIVATE ENTRANCE) OR TEMPORARY ACCESS (ROAD).

DIMENSIONS: IT SHALL BE THE CONTRACTOR'S RESPONSIBILITY TO VERIFY ALL DIMENSION AND CONDITIONS EXISTING IN THE FIELD PRIOR TO ORDERING MATERIALS AND BEGINNING CONSTRUCTION.

ALL SAWCUTTING SHALL BE INCLUDED IN THE UNIT COST OF THE ASSOCIATED ITEMS AND SHALL BE PERFORMED PRIOR TO BEGINNING REMOVAL. ANY ITEMS OF WORK REMOVED PRIOR TO SAWCUTTING WILL NOT BE MEASURED FOR PAYMENT.

PAVEMENT GRADES: THE ELEVATIONS INDICATED ON THE PLANS ARE FINISHED GRADES OF PROPOSED PAVEMENT OF SURFACE COURSE, UNLESS OTHERWISE INDICATED.

BARRICADES: THE CONTRACTOR SHALL PROVIDE AND INSTALL TWO (2) WEIGHTED SAND BAGS ON EACH TYPE I OR TYPE II BARRICADE USED. (ONE (1) WEIGHTED SAND BAG ACROSS EACH BOTTOM RAIL.)

RELOCATING EXISTING SIGNS: EXISTING SIGNS WHICH ARE IN CONFLICT WITH PROPOSED IMPROVEMENTS SHALL BE REMOVED AND REINSTALLED UPON COMPLETION OF CONFLICTING IMPROVEMENTS IN ACCORDANCE WITH THE ILLINOIS DEPARTMENT OF TRANSPORTATION "MANUAL OF UNIFORM TRAFFIC CONTROL DEVICES". THE COST ASSOCIATED FOR THIS WORK SHALL BE CONSIDERED INCIDENTAL TO THE COST OF THE CONTRACT. SIGNS DAMAGED IN RELOCATION PROCESS SHALL BE REPLACED IN KIND AT NO COST TO THE CITY

ANY EXISTING PAVEMENT DAMAGED BY THE CONTRACTOR DURING THE CONSTRUCTION SHALL BE REPLACED/REPAIRED BY THE CONTRACTOR AT HIS/HERS OWN EXPENSE TO THE SATISFACTION OF THE ENGINEER WITH NO ADDITIONAL COMPENSATION TO THE CONTRACTOR.

ALL TRANSITIONS IN CURB HEIGHT SHALL OCCUR OVER 6 FEET ALONG CURB LINE. AT LOCATIONS WHERE CURB TERMINATES, THE LAST 1 FOOT SHALL BE DEPRESSED. DEPRESSED CURB SHALL ALSO BE AT LOCATIONS SHOWN ON THE PLANS AND AS DIRECTED BY THE ENGINEER.

GENERAL NOTES

1. THE OWNER, THE CITY OF WILMINGTON SHALL BE NOTIFIED IN WRITING AT LEAST (3) FULL WORKING DAYS PRIOR TO COMMENCEMENT OF CONSTRUCTION.
2. THE CONTRACTOR SHALL PROVIDE ALL NECESSARY PROTECTION FOR EXISTING UTILITIES IN CONFORMANCE WITH THE AFFECTED UTILITY COMPANIES REQUIREMENTS AS MAY BE REQUIRED TO PERFORM THE WORK OF THIS CONTRACT.
3. BEFORE BEGINNING CONSTRUCTION, THE CONTRACTOR SHALL VERIFY THE LINE AND GRADES SHOWN ON THE CONTRACT DRAWINGS. IF THERE ARE ANY DISCREPANCIES FROM WHAT IS SHOWN ON THE CONTRACT DRAWINGS, THE CONTRACTOR SHALL IMMEDIATELY REPORT SAME TO THE OWNER PRIOR TO PERFORMING WORK. CONTRACTOR SHALL BE RESPONSIBLE FOR COORDINATION OF WORK AS REQUIRED. IF CONTRACTOR FAILS TO REPORT DISCREPANCIES BEFORE CONSTRUCTION, NO ADDITIONAL COMPENSATION WILL BE PAID FOR RESULTING DISCREPANCIES.
4. ALL ELEVATIONS SHOWN ON THE CONTRACT DRAWINGS ARE NAVD '88.
5. THE CONTRACT DOCUMENTS ARE NOT INTENDED TO SHOW EVERY AND ALL DETAILS OF WORK TO BE PERFORMED OR EQUIPMENT TO BE SUPPLIED, THE INTENT OF THE CONTRACT DOCUMENTS IS TO ILLUSTRATE THE CONCEPTUAL DESIGN AND LAYOUT. THE CONTRACTOR SHALL BE KNOWLEDGEABLE AND REGULARLY ENGAGED IN THE TYPE OF WORK DESCRIBED BY THESE CONTRACT DOCUMENTS, AND SHALL BE RESPONSIBLE FOR UNDERSTANDING THEIR INTENT. ANY WORK TO BE PERFORMED OR ITEM OF EQUIPMENT TO BE SUPPLIED WHICH IS NOT SPECIFICALLY CALLED FOR BY THESE CONTRACT DOCUMENTS BUT WHICH IS NECESSARY TO PROVIDE A COMPLETE AND SUCCESSFUL WORKING SYSTEM SHALL BE INCLUDED IN THE CONTRACTOR'S SCOPE OF WORK AT NO ADDITIONAL COST TO THE OWNER.
6. THE WORK PERFORMED UNDER THIS CONTRACT SHALL IN NO WAY INTERFERE WITH THE NORMAL OPERATION OF ANY EXISTING UTILITY SERVICE. THE CONTRACTOR SHALL FURNISH ALL NECESSARY ITEMS OF EQUIPMENT REQUIRED TO MAINTAIN SUCH NORMAL OPERATION AT NO ADDITIONAL COST TO THE OWNER. THE COST ASSOCIATED FOR THIS WORK SHALL BE CONSIDERED INCIDENTAL TO THE COST OF THE CONTRACT.
7. ORIENTATION OF PIPING, CONDUITS, EQUIPMENT, ETC. MAY VARY. CONTRACTOR TO COORDINATE SAME WITH THE OWNER.
8. ANY AND ALL DEWATERING REQUIRED TO KEEP EXCAVATIONS DRY SHALL BE THE RESPONSIBILITY OF THE CONTRACTOR.
9. CERTAIN INFORMATION SHOWN ON THESE DRAWINGS HAS BEEN OBTAINED FROM DRAWINGS OF RECORD. CONTRACTOR SHALL VERIFY SUCH INFORMATION PRIOR TO ACTUAL START OF WORK. WHERE DISCREPANCIES ARE DISCOVERED THE CONTRACTOR SHALL IMMEDIATELY NOTIFY THE OWNER'S REPRESENTATIVE. FAILURE BY THE CONTRACTOR TO IMMEDIATELY NOTIFY THE OWNER'S REPRESENTATIVE OF SUCH DISCREPANCIES SHALL RESULT IN THE CONTRACTOR BEARING THE FULL BURDEN OF ALL RISKS/COSTS ATTRIBUTED TO THE DISCOVERED DISCREPANCY.
10. PAY ITEMS IN THE SUMMARY OF QUANTITIES HAVE BEEN ESTIMATED. IF, IN THE ENGINEER'S OPINION, THE WORK IS NOT REQUIRED, THE ITEM WILL BE DEDUCTED FROM THE CONTRACT AND NO ADDITIONAL COMPENSATION WILL BE ALLOWED.
11. ONLY THOSE TREES DESIGNATED BY THE ENGINEER OR SHOWN ON THE PLANS SHALL BE REMOVED. THE CONTRACTOR SHALL PROTECT ALL REMAINING TREES FROM DAMAGE DUE TO HIS OPERATIONS. TREES DAMAGED DURING CONSTRUCTION SHALL BE REPAIRED AT NO ADDITIONAL COST TO THE CITY.
12. ALL CITY STREETS SHALL BE KEPT FREE OF ALL DIRT, DUST AND DEBRIS AT ALL TIMES. AT THE END OF EACH WORKING DAY THE ADJACENT CITY STREETS WILL BE CLEARED VIA STREET SWEEPER WITH WATER, AS REQUESTED BY THE ENGINEER, AS NEEDED TO ENSURE ALL STREETS ARE KEPT FREE AND CLEAR OF ALL DIRT, DUST AND DEBRIS.

STORM SEWER CONSTRUCTION NOTES

1. A VERTICAL SEPARATION OF EIGHTEEN (18) INCHES BETWEEN THE INVERT OF THE SEWER OR DRAIN AND THE CROWN OF THE WATER MAIN SHALL BE MAINTAINED WHERE A WATER MAIN CROSSES UNDER A SEWER. SUPPORT THE SEWER OR DRAIN LINES TO PREVENT SETTling AND BREAKING THE WATER MAIN, AS SHOWN ON THE PLANS OR AS APPROVED BY THE ENGINEER, WHICH SHALL BE INCLUDED IN THE COST OF THE WATER MAIN.
2. WHENEVER, DURING CONSTRUCTION, OPERATIONS ANY LOOSE MATERIAL IS DEPOSITED IN THE FLOW LINE OF DRAINAGE STRUCTURES SUCH THAT THE NATURAL FLOW OF WATER IS OBSTRUCTED, IT SHALL BE REMOVED AT THE CLOSE OF EACH WORKING DAY, AT THE CONCLUSION OF CONSTRUCTION OPERATIONS. ALL UTILITY STRUCTURES SHALL BE FREE FROM DIRT AND DEBRIS. THE WORK SPECIFIED ABOVE WILL NOT BE PAID FOR SEPARATELY BUT SHALL BE INCLUDED IN THE COST FOR THE STORM SEWER.
3. ANY EXISTING OR PROPOSED STORM SEWER DAMAGED BY THE CONTRACTOR DURING CONSTRUCTION SHALL BE REPLACED BY THE CONTRACTOR AT NO COST TO THE CITY.
4. DRAINAGE STRUCTURE OFFSETS AS SHOWN ON THE PLANS ARE GIVEN TO THE FOLLOWING POINTS: (A) FOR STRUCTURES FALLING IN THE CURB LINE - TO THE EDGE OF PAVEMENT; B) FOR ALL OTHER STRUCTURES - TO THE CENTER OF STRUCTURE.
5. TOP-OF-FRAME ELEVATIONS SHOWN ON THE PLANS FOR DRAINAGE STRUCTURES IN THE CURB LINE ARE EDGE-OF-PAVEMENT ELEVATIONS.
6. FRAME ELEVATIONS GIVEN ON THE PLANS ARE ONLY TO ASSIST THE CONTRACTOR IN DETERMINING THE APPROXIMATE OVERALL HEIGHT OF THE STRUCTURE. FRAMES OF ALL NEW, ADJUSTED OR RECONSTRUCTED STRUCTURES SHALL BE ADJUSTED TO THE FINAL ELEVATION OF THE AREA IN WHICH THEY ARE LOCATED AS PART OF THE STRUCTURE, ADJUSTMENT, OR RECONSTRUCTION COST.
7. WHEN EXISTING DRAINAGE OR SEWERAGE FACILITIES ARE DISTURBED, THE CONTRACTOR SHALL PROVIDE AND MAINTAIN TEMPORARY OUTLETS AND CONNECTIONS FOR ALL PUBLIC OR PRIVATE DRAINS, SEWERS, OR CATCH BASINS. HE SHALL PROVIDE FACILITIES TO TAKE ALL STORM WATER WHICH WOULD BE RECEIVED BY THESE FACILITIES AND DISCHARGE SAME. HE SHALL ALSO PROVIDE AND MAINTAIN AN EFFICIENT PUMPING PLANT, IF NECESSARY, AND A TEMPORARY OUTLET, AND BE PREPARED AT ALL TIMES TO DISPOSE OF THE WATER RECEIVED FROM THESE TEMPORARY CONNECTIONS UNTIL SUCH TIME THAT PERMANENT CONNECTIONS WITH SEWERS ARE CONSTRUCTED AND IN SERVICE. THIS WORK SHALL BE CONSIDERED INCIDENTAL TO THE CONTRACT.
8. THE CONTRACTOR SHALL NOT OPEN OR SHUT ANY WATER VALVES OR FIRE HYDRANTS WITHOUT PRIOR AUTHORIZATION FROM THE CITY. UNAUTHORIZED USE OF CITY WATER VALVES SHALL RESULT IN A FINE OF \$750 FOR EACH OCCURANCE.

CHAMLIN & ASSOCIATES, INC. © 2024 H:\PROJECTS\4814155-00 WILMINGTON SOUTH ISLAND PARK IMPROVEMENTS 2023\CADD\Sheet\GEN 01-14155.dgn

DRAWN BY: CJM	REVISIONS				 PERU OTTAWA MORRIS ILLINOIS	CLIENT:  CITY OF WILMINGTON 1165 S. Water Street Wilmington, Illinois 60481	SOUTH ISLAND PARK IMPROVEMENTS GENERAL NOTES	CURRENT AS OF:	2/08/2024	
	DESIGNED BY: CJM	NO.	BY	DATE				DESCRIPTION	SCALE: 1:50	SHEET 2
	CHECKED BY: REH								FILE NO.: 14155	OF 7

PLOTTED: 2/9/2024

CHAMLIN & ASSOCIATES, INC. © 2024
 H:\A\081748\14158-00 WILMINGTON SOUTH ISLAND PARK IMPROVEMENTS 2023\CAD\Sheet\SS00_01-14158.dgn

CODE NO.	ITEM	UNIT	TOTAL QUANTITY
20100110	TREE REMOVAL (6 TO 15 UNITS DIAMETER)	UNIT	18
20100210	TREE REMOVAL (OVER 15 UNITS DIAMETER)	UNIT	237
20101100	TREE TRUNK PROTECTION	EACH	21
20101200	TREE ROOT PRUNING	EACH	10
20200100	EARTH EXCAVATION	CU YD	1200
20201200	REMOVAL AND DISPOSAL OF UNSUITABLE MATERIAL	CU YD	65
20700220	POROUS GRANULAR EMBANKMENT	CU YD	65
20800150	TRENCH BACKFILL	CU YD	24
21001000	GEOTECHNICAL FABRIC FOR GROUND STABILIZATION	SQ YD	2000
21101625	TOPSOIL FURNISH AND PLACE, 6"	SQ YD	5250
25000110	SEEDING, CLASS 1A	ACRE	1.08
25000400	NITROGEN FERTILIZER NUTRIENT	POUND	100
25000500	PHOSPHORUS FERTILIZER NUTRIENT	POUND	100
25000600	POTASSIUM FERTILIZER NUTRIENT	POUND	100
25100630	EROSION CONTROL BLANKET	SQ YD	5250
28000510	INLET FILTERS	EACH	5
28100105	STONE RIPRAP, CLASS A3	SQ YD	4
30300112	AGGREGATE SUBGRADE IMPROVEMENT 12"	SQ YD	1250
35101600	AGGREGATE BASE COURSE, TYPE B 4"	SQ YD	900
35102100	AGGREGATE BASE COURSE, TYPE B 9"	SQ YD	750
40600275	BITUMINOUS MATERIALS (PRIME COAT)	POUND	6250

CODE NO.	ITEM	UNIT	TOTAL QUANTITY
40600290	BITUMINOUS MATERIALS (TACK COAT)	POUND	475
40603080	HOT-MIX ASPHALT BINDER COURSE, IL-19-0, N50	TON	163
40604050	HOT-MIX ASPHALT SURFACE COURSE, IL-9.5, MIX "C", N50	TON	359
42400200	PORTLAND CEMENT CONCRETE SIDEWALK 5 INCH	SQ FT	725
42400800	DETECTABLE WARNINGS	SQ FT	72
44000100	PAVEMENT REMOVAL	SQ YD	436
44000500	COMBINATION CURB AND GUTTER REMOVAL	FOOT	165
44000600	SIDEWALK REMOVAL	SQ FT	980
54213657	PRECAST REINFORCED CONCRETE FLARED END SECTIONS 12"	EACH	1
550A0340	STORM SEWERS, CLASS A, TYPE 2 12"	FOOT	130
550B0340	STORM SEWERS, CLASS B, TYPE 2 12"	FOOT	285
60236200	INLETS, TYPE A, TYPE 8 GRATE	EACH	5
60603800	COMBINATION CONCRETE CURB AND GUTTER, TYPE B-6.12	FOOT	275
60605000	COMBINATION CONCRETE CURB AND GUTTER, TYPE B-6.24	FOOT	75
67100100	MOBILIZATION	L SUM	1
72000100	SIGN PANEL - TYPE 1	SQ FT	2
72800100	TELESCOPING STEEL SIGN SUPPORT	FOOT	13
78001100	PAINT PAVEMENT MARKING - LETTERS AND SYMBOLS	SQ FT	4
78001110	PAINT PAVEMENT MARKING - LINE 4"	FOOT	290
X0320050	CONSTRUCTION LAYOUT (SPECIAL)	L SUM	1
X7010216	TRAFFIC CONTROL AND PROTECTION, (SPECIAL)	L SUM	1
Z0017400	DRAINAGE & UTILITY STRUCTURES TO BE ADJUSTED	EACH	5

DRAWN BY: CJM	REVISIONS		
DESIGNED BY: CJM	NO.	BY	DATE
CHECKED BY: REH			
PLOTTED: 2/9/2024			

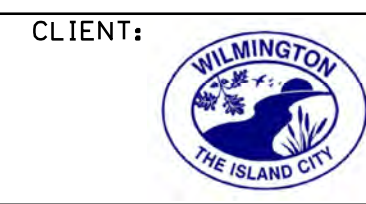

CITY OF WILMINGTON
 1165 S. Water Street
 Wilmington, Illinois 60481

**SOUTH ISLAND PARK IMPROVEMENTS
 SUMMARY OF QUANTITIES**

CURRENT AS OF:	2/08/2024
SCALE: 1:50	SHEET 3
FILE NO.: 14158	OF 7

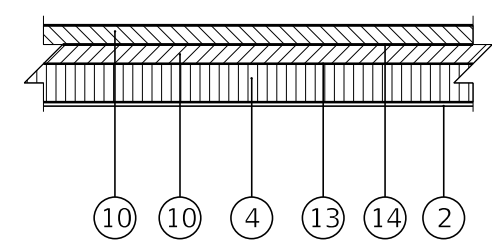

PARKING LOT TYPICAL SECTION

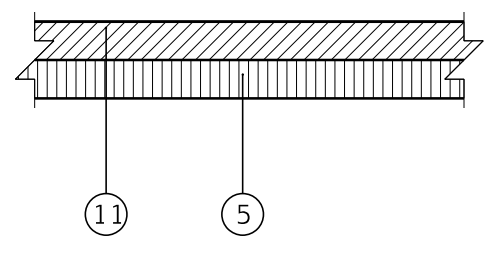

PATH TYPICAL SECTION

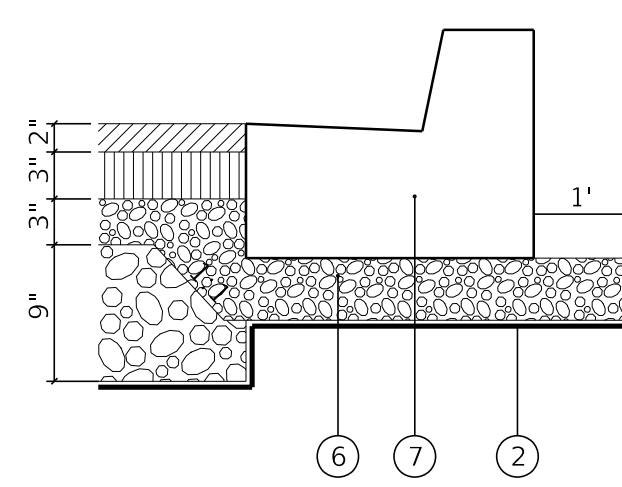

CURB AND GUTTER DETAIL

LEGEND

- ① EXISTING GROUND
- ② GEOTECHNICAL FABRIC FOR GROUND STABILIZATION
- ③ AGGREGATE SUBGRADE IMPROVEMENT, 12"
- ④ AGGREGATE BASE COURSE, TY B, 9"
- ⑤ AGGREGATE BASE COURSE, TY B, 4"
- ⑥ AGGREGATE BASE COURSE, TY B, 4" - MINIMUM (INCLUDED IN COST OF CONC. CURB AND GUTTER)
- ⑦ COMBINATION CONCRETE CURB AND GUTTER, TY B-6.12
- ⑧ PCC SIDEWALK, 5"
- ⑨ AGGREGATE BASE COURSE, TY B, 4" (INCLUDED IN COST OF PCC SIDEWALK, 5")
- ⑩ HMA SURFACE COURSE, MIX C, N50, 1.5"
- ⑪ HMA SURFACE COURSE, MIX C, N50, 3"
- ⑫ HMA BINDER COURSE, IL-19.0, N50, 2.5"
- ⑬ BITUMINOUS MATERIALS (PRIME COAT)
- ⑭ BITUMINOUS MATERIAL (TACK COAT)
- ⑮ TOPSOIL FURNISH AND PLACE, 6"
- ⑯ SEEDING, CLASS 1A
- ⑰ EROSION CONTROL BLANKET

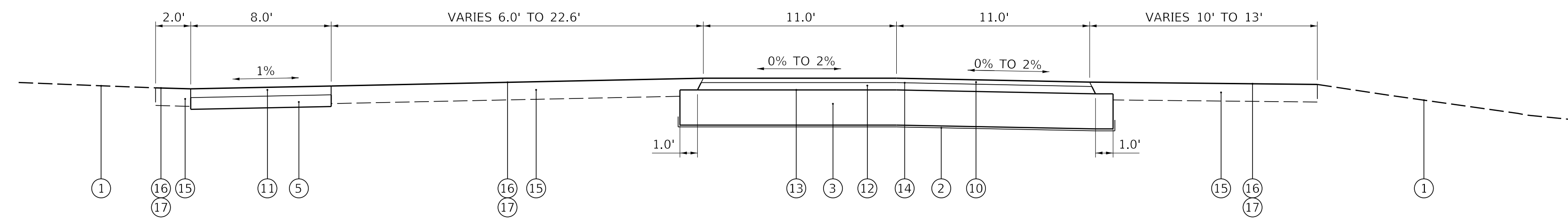

**PROPOSED TYPICAL SECTION
STA 50+00 - STA 51+25**

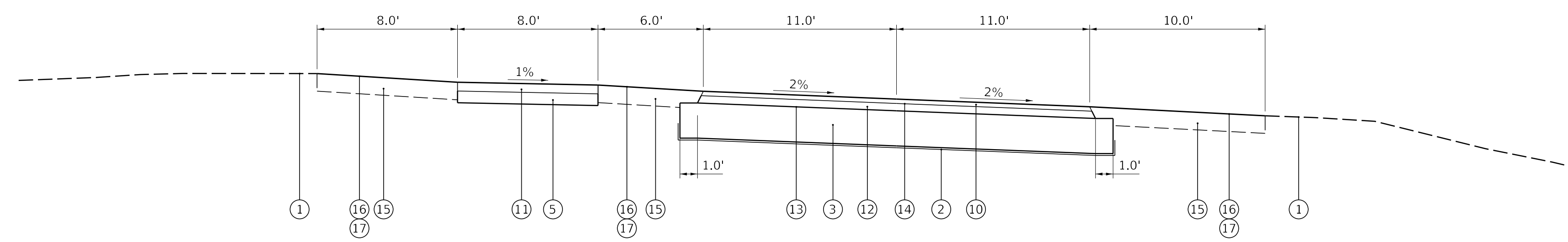

**PROPOSED TYPICAL SECTION
STA 51+25 - STA 52+59.16**

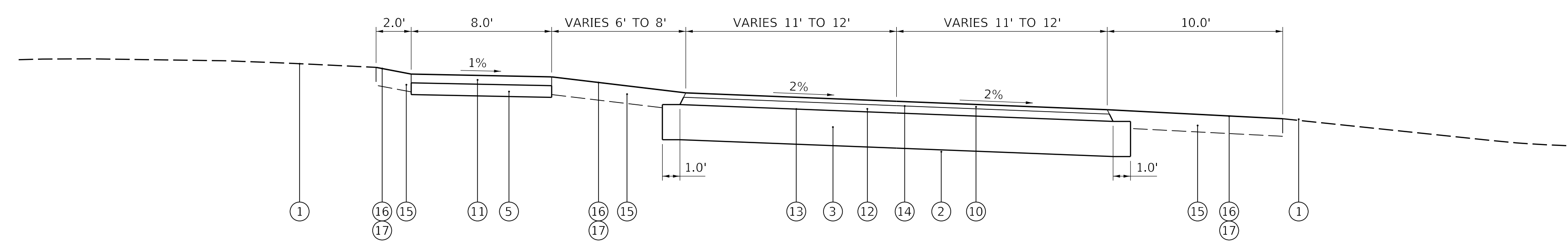

**PROPOSED TYPICAL SECTION
STA 52+59.16 - STA 52+84.12**

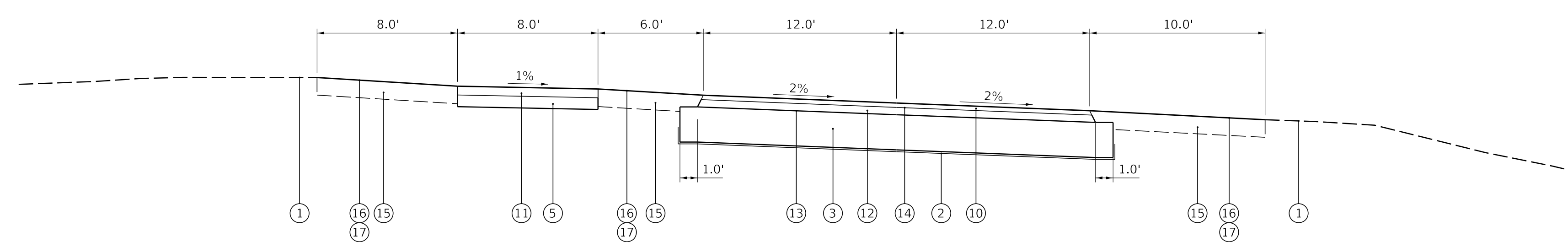

**PROPOSED TYPICAL SECTION
STA 52+59.16 - STA 53+18.25**

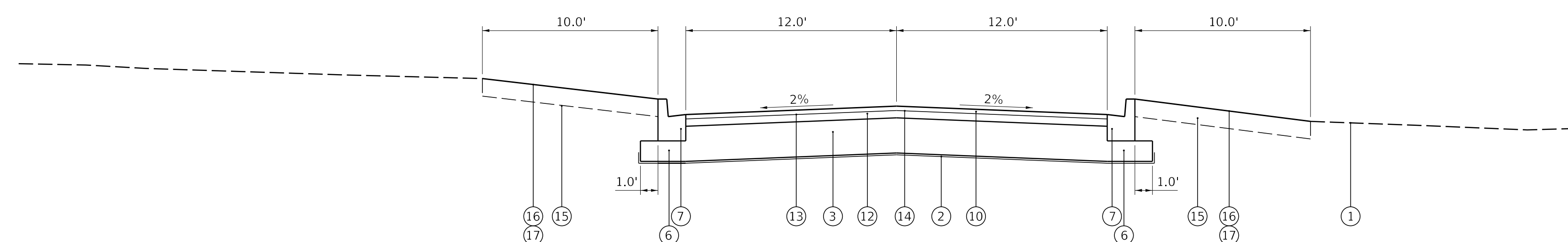

**PROPOSED TYPICAL SECTION
STA 53+18.25 - STA 54+37.04**

CHAMLIN & ASSOCIATES, INC. © 2024 H:\PROJECTS\41158-00 WILMINGTON SOUTH ISLAND PARK IMPROVEMENTS 2023\CAD\Sheet\TYP-01-14158.dgn

DRAWN BY: CJM	REVISIONS			
	NO.	BY	DATE	DESCRIPTION
DESIGNED BY: CJM				
CHECKED BY: REH				

CA CHAMLIN & ASSOCIATES
PERU OTTAWA MORRIS ILLINOIS

CLIENT: **CITY OF WILMINGTON**
1165 S. Water Street
Wilmington, Illinois 60481



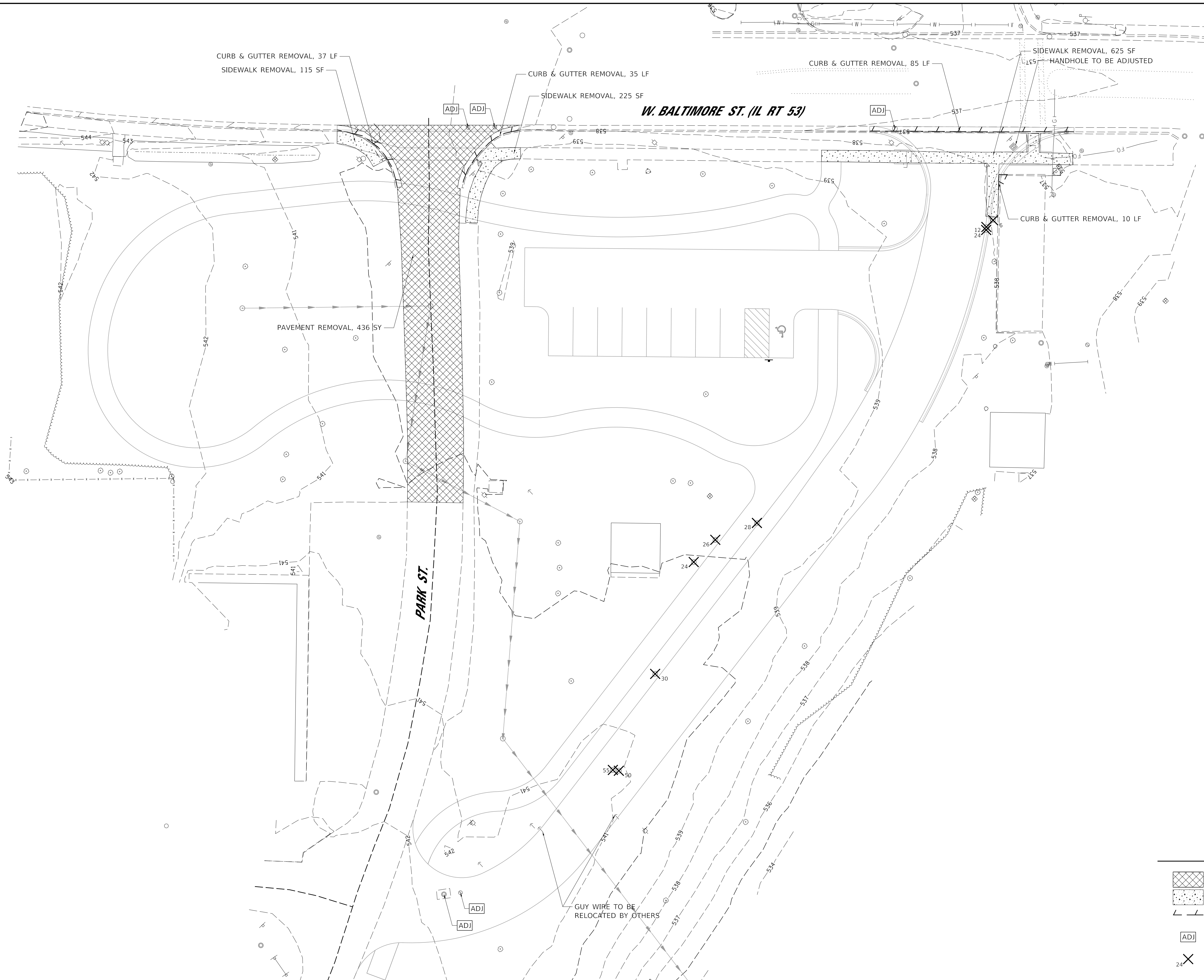
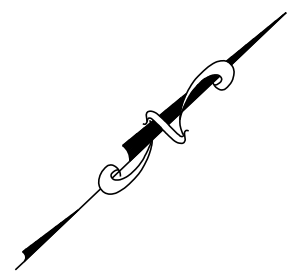

**SOUTH ISLAND PARK IMPROVEMENTS
TYPICAL SECTION**

CURRENT AS OF:	2/08/2024
SCALE: N.T.S.	SHEET 4
FILE NO.: 14158	OF 7

PLOTTED: 2/9/2024

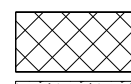

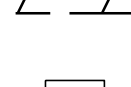
LEGEND

-  PAVEMENT REMOVAL
-  SIDEWALK REMOVAL
-  CURB AND GUTTER REMOVAL
-  DRAINAGE AND UTILITY STRUCTURE TO BE ADJUSTED
-  TREE REMOVAL

CHAMLIN & ASSOCIATES, INC. © 2024
 H:\AUG08\14158-00 WILMINGTON SOUTH ISLAND PARK IMPROVEMENTS 2023\CAD\Sheet\SRM_01-14158.dgn

DRAWN BY: CJM		NO.		BY	DATE	REVISIONS	DESCRIPTION
DESIGNED BY: CJM							
CHECKED BY: REH							
PLOTTED: 2/9/2024							



PERU OTTAWA MORRIS
ILLINOIS
Chamlin & Associates

CLIENT:  **CITY OF WILMINGTON**
 1165 S. Water Street
 Wilmington, Illinois 60481

SOUTH ISLAND PARK IMPROVEMENTS
EXISTING CONDITION AND REMOVAL PLAN

CURRENT AS OF:	2/08/2024
SCALE: 1:20	SHEET 5
FILE NO.: 14158	OF 7

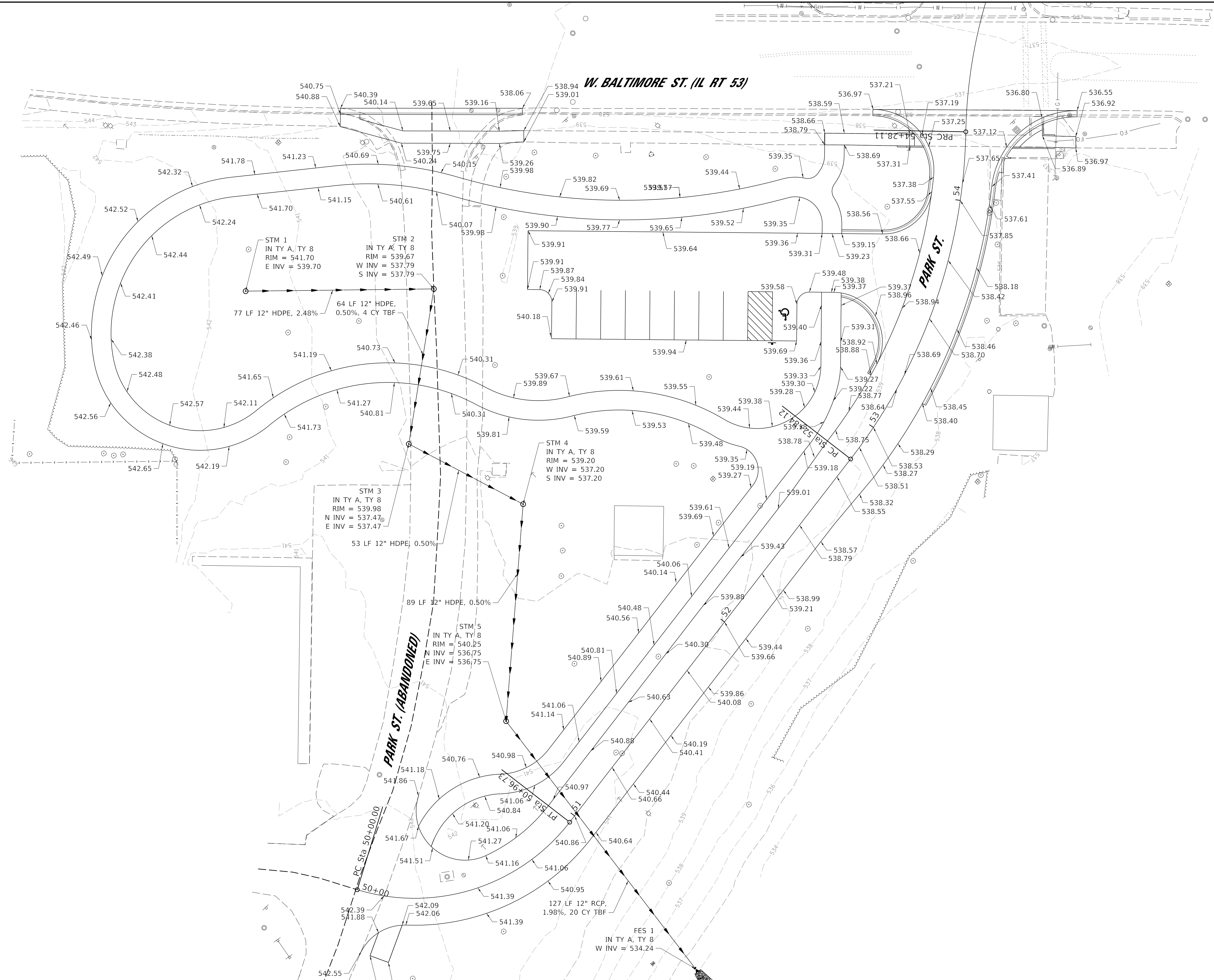
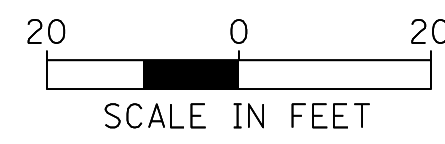

CHAMLIN & ASSOCIATES, INC. © 2024
 H:\AUGUST 2023\CAD\Sheet\Sheet\IGRD_01-14158.dwg
 WILMINGTON SOUTH ISLAND PARK IMPROVEMENTS 2023

DRAWN BY: CJM	REVISIONS			
	NO.	BY	DATE	DESCRIPTION
DESIGNED BY: CJM				
CHECKED BY: REH				
PLOTTED: 2/9/2024				

PERU OTTAWA MORRIS
ILLINOIS
Chamlin & Associates

CLIENT:  **CITY OF WILMINGTON**
 1165 S. Water Street
 Wilmington, Illinois 60481

SOUTH ISLAND PARK IMPROVEMENTS
PROPOSED GRADING PLAN

CURRENT AS OF:	2/08/2024
SCALE: 1:20	SHEET 7
FILE NO.: 14158	OF 7



**Illinois Department
of Transportation**

Project South Island Park
Route Park Street
Section _____
County Will

Estimate of Cost

Location of Improvement: North end of South Island Park, City of Wilmington Illinois

For a total distance of _____ Net improvement of _____

Type _____ Width _____ Thickness _____

Shoulders _____ Average Haul _____ Maximum Grade _____ %

Code Number	Item	Unit of Measure	Quantity	Unit Price	Total Cost
20100110	TREE REMOVAL (6 TO 15 UNITS DIAMETER)	UNIT	18	\$30.00	\$540.00
20100210	TREE REMOVAL (OVER 15 UNITS DIAMETER)	UNIT	237	\$30.00	\$7,110.00
20101100	TREE TRUNK PROTECTION	EACH	21	\$200.00	\$4,200.00
20101200	TREE ROOT PRUNING	EACH	10	\$200.00	\$2,000.00
20200100	EARTH EXCAVATION	CU YD	1200	\$30.00	\$36,000.00
20201200	REMOVAL AND DISPOSAL OF UNSUITABLE MATERIAL	CU YD	65	\$30.00	\$1,950.00
20700220	POROUS GRANULAR EMBANKMENT	CU YD	65	\$30.00	\$1,950.00
20800150	TRENCH BACKFILL	CU YD	24	\$30.00	\$720.00
21001000	GEOTECHNICAL FABRIC FOR GROUND STABILIZATION	SQ YD	2000	\$2.00	\$4,000.00
21101625	TOPSOIL FURNISH AND PLACE, 6"	SQ YD	5250	\$5.50	\$28,875.00
25000110	SEEDING, CLASS 1A	ACRE	1.08	\$1,000.00	\$1,080.00
25000400	NITROGEN FERTILIZER NUTRIENT	POUND	100	\$3.00	\$300.00
25000500	PHOSPHORUS FERTILIZER NUTRIENT	POUND	100	\$3.00	\$300.00
25000600	POTASSIUM FERTILIZER NUTRIENT	POUND	100	\$3.00	\$300.00
25100630	EROSION CONTROL BLANKET	SQ YD	5250	\$2.50	\$13,125.00
28000510	INLET FILTERS	EACH	5	\$200.00	\$1,000.00
28100105	STONE RIPRAP, CLASS A3	SQ YD	4	\$20.00	\$80.00
30300112	AGGREGATE SUBGRADE IMPROVEMENT 12"	SQ YD	1250	\$18.00	\$22,500.00
35101600	AGGREGATE BASE COURSE, TYPE B 4"	SQ YD	900	\$10.00	\$9,000.00
35102100	AGGREGATE BASE COURSE, TYPE B 9"	SQ YD	750	\$16.00	\$12,000.00
40600275	BITUMINOUS MATERIALS (PRIME COAT)	POUND	6250	\$1.00	\$6,250.00
40600290	BITUMINOUS MATERIALS (TACK COAT)	POUND	475	\$1.00	\$475.00
40603080	HOT-MIX ASPHALT BINDER COURSE, IL-19.0, N50	TON	163	\$80.00	\$13,040.00
40604050	HOT-MIX ASPHALT SURFACE COURSE, IL-9.5, MIX "C", N50	TON	359	\$80.00	\$28,720.00
42400200	PORTLAND CEMENT CONCRETE SIDEWALK 5 INCH	SQ FT	725	\$8.00	\$5,800.00
42400800	DETECTABLE WARNINGS	SQ FT	72	\$30.00	\$2,160.00
44000100	PAVEMENT REMOVAL	SQ YD	436	\$10.00	\$4,360.00
44000500	COMBINATION CURB AND GUTTER REMOVAL	FOOT	165	\$10.00	\$1,650.00

44000600	SIDEWALK REMOVAL	SQ FT	980	\$3.00	\$2,940.00
54213657	PRECAST REINFORCED CONCRETE FLARED END SECTIONS 12"	EACH	1	\$850.00	\$850.00
550A0340	STORM SEWERS, CLASS A, TYPE 2 12"	FOOT	130	\$65.00	\$8,450.00
550B0340	STORM SEWERS, CLASS B, TYPE 2 12"	FOOT	285	\$50.00	\$14,250.00
60236200	INLETS, TYPE A, TYPE 8 GRATE	EACH	5	\$1,200.00	\$6,000.00
60603800	GUTTER, TYPE B-6.12	FOOT	275	\$20.00	\$5,500.00
60605000	GUTTER, TYPE B-6.24	FOOT	75	\$30.00	\$2,250.00
67100100	MOBILIZATION	L SUM	1	\$8,288.51	\$8,288.51
72000100	SIGN PANEL - TYPE 1	SQ FT	2	\$30.00	\$60.00
72800100	TELESCOPING STEEL SIGN SUPPORT	FOOT	13	\$8.00	\$104.00
78001100	PAINT PAVEMENT MARKING - LETTERS AND SYMBOLS	SQ FT	4	\$6.50	\$26.00
78001110	PAINT PAVEMENT MARKING - LINE 4"	FOOT	290	\$2.00	\$580.00
X0320050	CONSTRUCTION LAYOUT (SPECIAL)	L SUM	1	\$10,000.00	\$10,000.00
X7010216	TRAFFIC CONTROL AND PROTECTION, (SPECIAL)	L SUM	1	\$5,000.00	\$5,000.00
Z0017400	DRAINAGE & UTILITY STRUCTURES TO BE ADJUSTED	EACH	5	\$500.00	\$2,500.00
TOTAL ESTIMATED COST OF WORK INCLUDING ALL LABOR, MATERIALS AND PROFITS.					\$276,283.51

Made by CJM Date 2/8/2024 Examined _____, _____
Checked by REH Date 2/9/2024 _____ Regional Engineer



MEMO

Date: February 9, 2024

To: Honorable Mayor Dietz and City Council Members

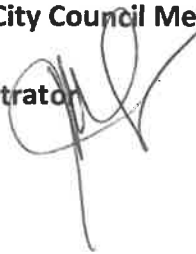
From: Jeannine Smith, City Administrator 

Cc: Joie Ziller, Deputy Clerk
Department Directors

Re: Intergovernmental Agreement with the State of Illinois Department of Natural Resources

Budget Impact: Est. total match of \$110,000

History: The Will County Forest Preserve District and the City of Wilmington entered into an Intergovernmental Agreement (“IGA”) which is a requirement for a grant application submitted for a kayak launch at North Island. Currently there are no launch sites in Wilmington and the North Island is a popular launch area for kayakers. You will note on the next page, organizations such as paddleillinoiswatertrails.org and www.illinoispaddle.com direct people to this area as a place of portage.

The Wilmington City Council approved the IGA and the grant application was submitted in Spring of 2023. Subsequently, Staff and the Wilmington Park District spent time with a representative of the Illinois Department of Natural Resources last summer identifying the proposed location of the launch and completing required forms substantiating the need and the appropriateness of the launch site.

On January 29, 2024 the City received notice that we received the grant. The City is now required to enter into an agreement (“Agreement”) with the State of Illinois prior to receiving funds. Pursuant to the Agreement, the City would receive \$80,000 toward the project; the remainder of which would be split between the Forest Preserve District and the City. The current estimated project cost is \$300,000. Therefore, \$220,000 would be split equally.

Staff Analysis: Staff has reviewed the Agreement before you and respectfully requests your approval to move this item to the February 13, 2024 meeting for consideration.

Forest Preserve District of Will County North Island Canoe and Kayak Launch Project Location Map

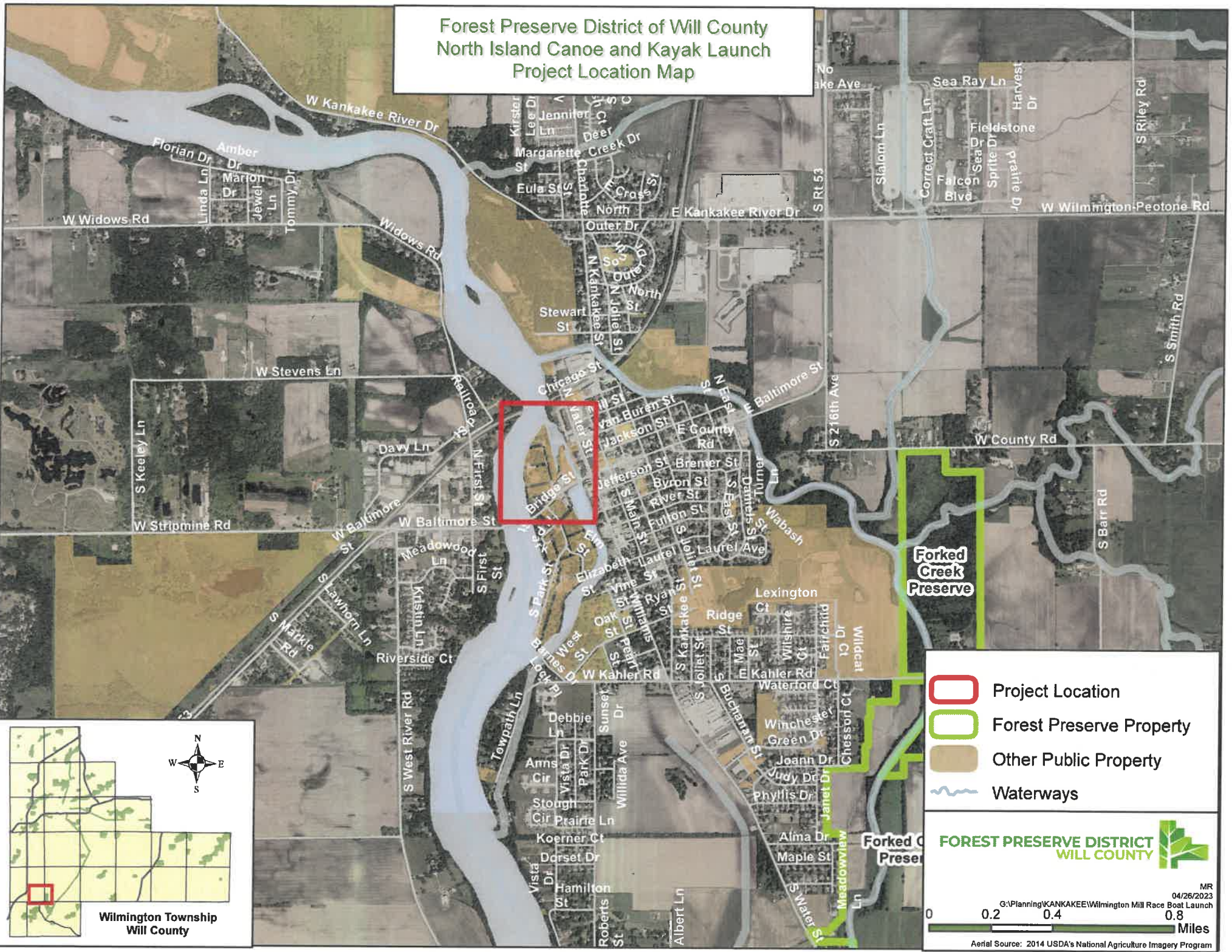

- Project Location
- Forest Preserve Property
- Other Public Property
- Waterways

FOREST PRESERVE DISTRICT
WILL COUNTY

MR
04/26/2023
G:\Planning\KANKAKEE\Wilmington Mill Race Boat Launch
0 0.2 0.4 0.8
Miles
Aerial Source: 2014 USDA's National Agriculture Imagery Program

Wilmington Township
Will County



WILMINGTON DAM TO DES PLAINES CONSERVATION AREA BOAT LAUNCH

SKILL LEVEL: Beginner To Intermediate Depending On Water Levels

TRAIL LENGTH: 5.65 Miles

WATERWAY TRAIL: Kankakee River Trails

Intermediate, Kankakee River Trails, Medium Trips

WILMINGTON DAM TO DES PLAINES CONSERVATION AREA BOAT LAUNCH

Directions: Put-in downstream of the Wilmington Dam or at the downstream end of South Island, which on the east bank of the Kankakee River, in downtown Wilmington.

The take-out is on river right approximately 1.5 miles past the I-55 Bridge.

Access the Des Plaines Fish and Wildlife Area Boat Launch from the west side of N. River Road, just north of the intersection with I-55.

Note: Camping is available at the Des Plaines Fish and Wildlife Area. The campground is open from mid-April to mid-October, closed the rest of the year.

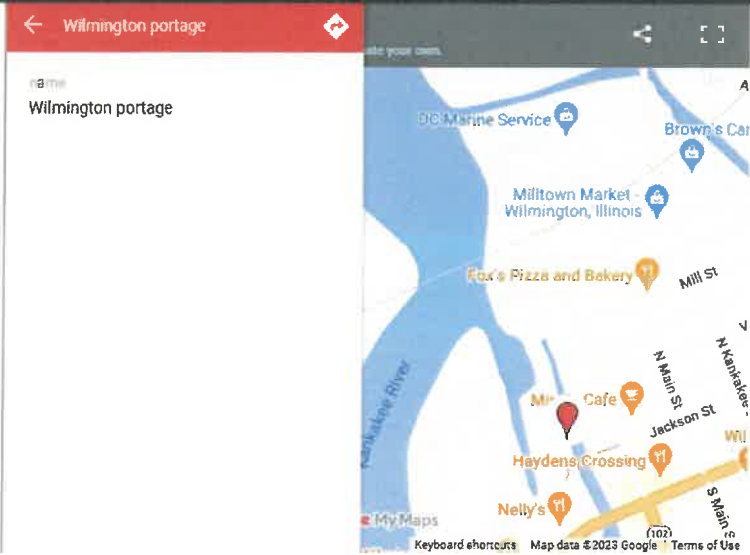

EXAMPLE OF WHAT AN ACCESSIBLE KAYAK LAUNCH LOOKS LIKE





**GRANT AGREEMENT
BETWEEN
THE STATE OF ILLINOIS, Natural Resources
AND
City of Wilmington**

The parties to this Grant Agreement (Agreement) are the State of Illinois (State), acting through the undersigned agency (Grantor) and City of Wilmington (Grantee) (collectively, the "Parties" and individually, a "Party"). The Agreement, consisting of the signature page, the parts listed below, and any additional exhibits or attachments referenced in this Agreement, constitute the entire agreement between the Parties. No promises, terms, or conditions not recited, incorporated or referenced herein, including prior agreements or oral discussions, are binding upon either Grantee or Grantor.

PART ONE – The Uniform Terms

Article I	Definitions
Article II	Award Information
Article III	Grantee Certifications and Representations
Article IV	Payment Requirements
Article V	Scope of Award Activities/Purpose of Award
Article VI	Budget
Article VII	Allowable Costs
Article VIII	Lobbying
Article IX	Maintenance and Accessibility of Records; Monitoring
Article X	Financial Reporting Requirements
Article XI	Performance Reporting Requirements
Article XII	Audit Requirements
Article XIII	Termination; Suspension; Non-compliance
Article XIV	Subcontracts/Subawards
Article XV	Notice of Change
Article XVI	Structural Reorganization and Reconstitution of Board Membership
Article XVII	Conflict of Interest
Article XVIII	Equipment or Property
Article XIX	Promotional Materials; Prior Notification
Article XX	Insurance
Article XXI	Lawsuits and Indemnification
Article XXII	Miscellaneous
Exhibit A	Project Description
Exhibit B	Deliverables or Milestones
Exhibit C	Contact Information
Exhibit D	Performance Measures and Standards
Exhibit E	Specific Conditions

PART TWO – Grantor-Specific Terms

PART THREE – Project-Specific Terms

The Parties or their duly authorized representatives hereby execute this Agreement.

Department of Natural Resources

By: _____

Signature of Director, Natalie Finnie

By: _____

Signature of Designee

Date: _____

Printed Name: _____

Printed Title: _____

Designee

City of Wilmington

By: _____

Signature of Authorized Representative

Date: _____

Printed Name: _____

Printed Title: _____

E-mail: _____

By: _____

Signature of Second Grantor Approver, if applicable

Date: _____

Printed Name: _____

Printed Title: _____

Second Grantor Approver

By: _____

Signature of Second Grantee Approver, if applicable

Date: _____

Printed Name: _____

Printed Title: _____

Second Grantee Approver
(optional at Grantee's discretion)

By: _____

Signature of Third Grantor Approver, if applicable

Date: _____

Printed Name: _____

Printed Title: _____

Third Grantor Approver

PART ONE – THE UNIFORM TERMS

**ARTICLE I
DEFINITIONS**

1.1. Definitions. Capitalized words and phrases used in this Agreement have the meanings stated in 2 CFR 200.1 unless otherwise stated below.

“Allowable Costs” has the same meaning as in 44 Ill. Admin. Code 7000.30.

“Award” has the same meaning as in 44 Ill. Admin. Code 7000.30.

“Budget” has the same meaning as in 44 Ill. Admin. Code 7000.30.

“Catalog of State Financial Assistance” or “CSFA” has the same meaning as in 44 Ill. Admin. Code 7000.30.

“Close-out Report” means a report from the Grantee allowing Grantor to determine whether all applicable administrative actions and required work have been completed, and therefore closeout actions can commence.

“Conflict of Interest” has the same meaning as in 44 Ill. Admin. Code 7000.30.

“Cooperative Research and Development Agreement” has the same meaning as in 15 USC 3710a.

“Direct Costs” has the same meaning as in 44 Ill. Admin. Code 7000.30.

“Financial Assistance” has the same meaning as in 44 Ill. Admin. Code 7000.30.

“GATU” has the same meaning as in 44 Ill. Admin. Code 7000.30.

“Grant Agreement” has the same meaning as in 44 Ill. Admin. Code 7000.30.

“Grant Funds” means the Financial Assistance made available to Grantee through this Agreement.

“Grantee Portal” has the same meaning as in 44 Ill. Admin. Code 7000.30.

“Indirect Costs” has the same meaning as in 44 Ill. Admin. Code 7000.30.

“Indirect Cost Rate” means a device for determining in a reasonable manner the proportion of Indirect Costs each Program should bear. It is a ratio (expressed as a percentage) of the Indirect Costs to a Direct Cost base. If reimbursement of Indirect Costs is allowable under an Award, Grantor will not reimburse those Indirect Costs unless Grantee has established an Indirect Cost Rate covering the applicable activities and period of time, unless Indirect Costs are reimbursed at a fixed rate.

“Indirect Cost Rate Proposal” has the same meaning as in 44 Ill. Admin. Code 7000.30.

“Obligations” has the same meaning as in 44 Ill. Admin. Code 7000.30.

“Period of Performance” has the same meaning as in 44 Ill. Admin. Code 7000.30.

"Prior Approval" has the same meaning as in 44 Ill. Admin. Code 7000.30.

"Profit" means an entity's total revenue less its operating expenses, interest paid, depreciation, and taxes. "Profit" is synonymous with the term "net revenue."

"Program" means the services to be provided pursuant to this Agreement. "Program" is used interchangeably with "Project."

"Program Costs" means all Allowable Costs incurred by Grantee and the value of the contributions made by third parties in accomplishing the objectives of the Award during the Term of this Agreement.

"Related Parties" has the meaning set forth in Financial Accounting Standards Board (FASB) Accounting Standards Codification (ASC) 850-10-20.

"SAM" means the federal System for Award Management (SAM), the federal repository into which an entity must provide information required for the conduct of business as a recipient.

"State Grantee Compliance Enforcement System" means the statewide framework for State agencies to manage occurrences of non-compliance with Award requirements.

"State-issued Award" means the assistance that a grantee receives directly from a State agency. The funding source of the State-issued Award can be federal pass-through, State or a combination thereof. "State-issued Award" does not include the following:

- contracts issued pursuant to the Illinois Procurement Code that a State agency uses to buy goods or services from a contractor or a contract to operate State government-owned, contractor-operated facilities;
- agreements that meet the definition of "contract" under 2 CFR 200.1 and 2 CFR 200.331, which a State agency uses to procure goods or services but are exempt from the Illinois Procurement Code due to an exemption listed under 30 ILCS 500/1-10, or pursuant to a disaster proclamation, executive order, or any other exemption permitted by law;
- amounts received for services rendered to an individual;
- Cooperative Research and Development Agreements;
- an agreement that provides only direct cash assistance to an individual;
- a subsidy;
- a loan;
- a loan guarantee; or
- insurance.

"Illinois Stop Payment List" has the same meaning as in 44 Ill. Admin. Code 7000.30.

"Unallowable Cost" has the same meaning as in 44 Ill. Admin. Code 7000.30.

"Unique Entity Identifier" or "UEI" has the same meaning as in 44 Ill. Admin. Code 7000.30.

**ARTICLE II
AWARD INFORMATION**

2.1. Term. This Agreement is effective Upon execution by the Director and expires on **03/31/2026** (the Term), unless terminated pursuant to this Agreement.

2.2. Amount of Agreement. Grant Funds **\$80,000.00**, of which **\$0.00** are federal funds. Grantee accepts Grantor's payment as specified in this ARTICLE.

2.3. Payment. Payment will be made as follows (see additional payment requirements in ARTICLE IV; additional payment provisions specific to this Award may be included in **PART TWO** or **PART THREE**):

2.4. Award Identification Numbers. If applicable, the Federal Award Identification Number (FAIN) is , the federal awarding agency is , and the Federal Award date is . If applicable, the Assistance Listing Program Title is and Assistance Listing Number is . The Catalog of State Financial Assistance (CSFA) Number is **422-11-1095** and the CSFA Name is **BAAD - Boat Access Area Development (FY23)**. If applicable, the State Award Identification Number (SAIN) is **BA 23-316 Wilmington, City of**.

**ARTICLE III
GRANTEE CERTIFICATIONS AND REPRESENTATIONS**

3.1. Registration Certification. Grantee certifies that: (i) it is registered with SAM and **FJNLGB8J3EE5** is Grantee's correct UEI; (ii) it is in good standing with the Illinois Secretary of State, if applicable; and (iii) Grantee has successfully completed the annual registration and prequalification through the Grantee Portal.

Grantee must remain current with these registrations and requirements. If Grantee's status with regard to any of these requirements changes, or the certifications made in and information provided in the uniform grant application changes, Grantee must notify Grantor in accordance with ARTICLE XV.

3.2. Tax Identification Certification. Grantee certifies that: **366006159** is Grantee's correct federal employer identification number (FEIN) or Social Security Number. Grantee further certifies, if applicable: (a) that Grantee is not subject to backup withholding because (i) Grantee is exempt from backup withholding, or (ii) Grantee has not been notified by the Internal Revenue Service (IRS) that Grantee is subject to backup withholding as a result of a failure to report all interest or dividends, or (iii) the IRS has notified Grantee that Grantee is no longer subject to backup withholding; and (b) Grantee is a U.S. citizen or other U.S. person. Grantee is doing business as a :

If Grantee has not received a payment from the State of Illinois in the last two years, Grantee must submit a W-9 tax form with this Agreement.

3.3. Compliance with Uniform Grant Rules. Grantee certifies that it must adhere to the applicable Uniform Administrative Requirements, Cost Principles, and Audit Requirements for Federal Awards, which are published in Title 2, Part 200 of the Code of Federal Regulations (2 CFR Part 200) and are incorporated herein by reference. 44 Ill. Admin. Code 7000.40(c)(1)(A). The requirements of 2 CFR Part 200 apply to the Grant Funds awarded through this Agreement, regardless of whether the original source of the funds is State or federal, unless an exception is noted in federal or State statutes or regulations. 30 ILCS 708/5(b).

3.4. Representations and Use of Funds. Grantee certifies under oath that (1) all representations made in this Agreement are true and correct and (2) all Grant Funds awarded pursuant to this Agreement must be used

only for the purpose(s) described herein. Grantee acknowledges that the Award is made solely upon this certification and that any false statements, misrepresentations, or material omissions will be the basis for immediate termination of this Agreement and repayment of all Grant Funds.

3.5. **Specific Certifications.** Grantee is responsible for compliance with the enumerated certifications in this Paragraph to the extent that the certifications apply to Grantee.

(a) **Bribery.** Grantee certifies that it has not been convicted of bribery or attempting to bribe an officer or employee of the State of Illinois, nor made an admission of guilt of such conduct which is a matter of record.

(b) **Bid Rigging.** Grantee certifies that it has not been barred from contracting with a unit of State or local government as a result of a violation of Paragraph 33E-3 or 33E-4 of the Criminal Code of 2012 (720 ILCS 5/33E-3 or 720 ILCS 5/33E-4, respectively).

(c) **Debt to State.** Grantee certifies that neither it, nor its affiliate(s), is/are barred from receiving an Award because Grantee, or its affiliate(s), is/are delinquent in the payment of any debt to the State, unless Grantee, or its affiliate(s), has/have entered into a deferred payment plan to pay off the debt.

(d) **International Boycott.** Grantee certifies that neither it nor any substantially owned affiliated company is participating or will participate in an international boycott in violation of the provision of the Anti-Boycott Act of 2018, Part II of the Export Control Reform Act of 2018 (50 USC 4841 through 4843), and the anti-boycott provisions set forth in Part 760 of the federal Export Administration Regulations (15 CFR Parts 730 through 774).

(e) **Discriminatory Club Dues or Fees.** Grantee certifies that it is not prohibited from receiving an Award because it pays dues or fees on behalf of its employees or agents, or subsidizes or otherwise reimburses employees or agents for payment of their dues or fees to any club which unlawfully discriminates (775 ILCS 25/2).

(f) **Pro-Children Act.** Grantee certifies that it is in compliance with the Pro-Children Act of 2001 in that it prohibits smoking in any portion of its facility used for the provision of health, day care, early childhood development services, education or library services to children under the age of eighteen (18) (except such portions of the facilities which are used for inpatient substance abuse treatment) (20 USC 7181-7184).

(g) **Drug-Free Workplace.** If Grantee is not an individual, Grantee certifies it will provide a drug free workplace pursuant to the Drug Free Workplace Act. 30 ILCS 580/3. If Grantee is an individual and this Agreement is valued at more than \$5,000, Grantee certifies it will not engage in the unlawful manufacture, distribution, dispensation, possession, or use of a controlled substance during the performance of the Agreement. 30 ILCS 580/4. Grantee further certifies that if it is a recipient of federal pass-through funds, it is in compliance with the government-wide requirements for a drug-free workplace as set forth in 41 USC 8103.

(h) **Motor Voter Law.** Grantee certifies that it is in full compliance with the terms and provisions of the National Voter Registration Act of 1993 (52 USC 20501 *et seq.*).

(i) **Clean Air Act and Clean Water Act.** Grantee certifies that it is in compliance with all applicable standards, orders or regulations issued pursuant to the Clean Air Act (42 USC 7401 *et seq.*) and the Federal Water Pollution Control Act, as amended (33 USC 1251 *et seq.*).

(j) **Debarment.** Grantee certifies that it is not debarred, suspended, proposed for debarment or permanent inclusion on the Illinois Stop Payment List, declared ineligible, or voluntarily excluded from participation in this Agreement by any federal department or agency (2 CFR 200.205(a)), or by the State (30 ILCS 708/25(6)(G)).

(k) **Non-procurement Debarment and Suspension.** Grantee certifies that it is in compliance with Subpart C of 2 CFR Part 180 as supplemented by 2 CFR Part 376, Subpart C.

(l) **Health Insurance Portability and Accountability Act.** Grantee certifies that it is in compliance with the Health Insurance Portability and Accountability Act of 1996 (HIPAA) (Public Law No. 104-191, 45 CFR Parts 160, 162 and 164, and the Social Security Act, 42 USC 1320d-2 through 1320d-7), in that it may not use or disclose protected health information other than as permitted or required by law and agrees to use appropriate safeguards to prevent use or disclosure of the protected health information. Grantee must maintain, for a minimum of six (6) years, all protected health information.

(m) **Criminal Convictions.** Grantee certifies that:

(i) Neither it nor a managerial agent of Grantee (for non-governmental grantees only, this includes any officer, director or partner of Grantee) has been convicted of a felony under the Sarbanes-Oxley Act of 2002, nor a Class 3 or Class 2 felony under Illinois Securities Law of 1953, or that at least five (5) years have passed since the date of the conviction; and

(ii) It must disclose to Grantor all violations of criminal law involving fraud, bribery or gratuity violations potentially affecting this Award. Failure to disclose may result in remedial actions as stated in the Grant Accountability and Transparency Act. 30 ILCS 708/40. Additionally, if Grantee receives over \$10 million in total federal Financial Assistance, during the period of this Award, Grantee must maintain the currency of information reported to SAM regarding civil, criminal or administrative proceedings as required by 2 CFR 200.113 and Appendix XII of 2 CFR Part 200, and 30 ILCS 708/40.

(n) **Federal Funding Accountability and Transparency Act of 2006 (FFATA).** Grantee certifies that it is in compliance with the terms and requirements of 31 USC 6101 with respect to Federal Awards greater than or equal to \$30,000. A FFATA subaward report must be filed by the end of the month following the month in which the award was made.

(o) **Illinois Works Review Panel.** For Awards made for public works projects, as defined in the Illinois Works Jobs Program Act, Grantee certifies that it and any contractor(s) or subcontractor(s) that performs work using funds from this Award, must, upon reasonable notice, appear before and respond to requests for information from the Illinois Works Review Panel. 30 ILCS 559/20-25(d).

(p) **Anti-Discrimination.** Grantee certifies that its employees and subcontractors under subcontract made pursuant to this Agreement, must comply with all applicable provisions of State and federal laws and regulations pertaining to nondiscrimination, sexual harassment and equal employment opportunity including, but not limited to: Illinois Human Rights Act (775 ILCS 5/1-101 *et seq.*), including, without limitation, 44 Ill. Admin. Code 750- Appendix A, which is incorporated herein; Public Works Employment Discrimination Act (775 ILCS 10/1 *et seq.*); Civil Rights Act of 1964 (as amended) (42 USC 2000a - 2000h-6); Section 504 of the Rehabilitation Act of 1973 (29 USC 794); Americans with Disabilities Act of 1990 (as amended) (42 USC 12101 *et seq.*); and the Age Discrimination Act of 1975 (42 USC 6101 *et seq.*).

(q) **Internal Revenue Code and Illinois Income Tax Act.** Grantee certifies that it complies with all provisions of the federal Internal Revenue Code (26 USC 1), the Illinois Income Tax Act (35 ILCS 5), and all regulations and rules promulgated thereunder, including withholding provisions and timely deposits of employee taxes and unemployment insurance taxes.

**ARTICLE IV
PAYMENT REQUIREMENTS**

4.1. **Availability of Appropriation; Sufficiency of Funds.** This Agreement is contingent upon and subject to the availability of sufficient funds. Grantor may terminate or suspend this Agreement, in whole or in part, without penalty or further payment being required, if (i) sufficient funds for this Agreement have not been appropriated or otherwise made available to Grantor by the State or the federal funding source, (ii) the Governor or Grantor reserves funds, or (iii) the Governor or Grantor determines that funds will not or may not be available for payment. Grantor must provide notice, in writing, to Grantee of any such funding failure and its election to terminate or suspend this Agreement as soon as practicable. Any suspension or termination pursuant to this Paragraph will be effective upon the date of the written notice unless otherwise indicated.

4.2. **Pre-Award Costs.** Pre-award costs are not permitted unless specifically authorized by Grantor in **Exhibit A, PART TWO or PART THREE** of this Agreement. If they are authorized, pre-award costs must be charged to the initial Budget Period of the Award, unless otherwise specified by Grantor. 2 CFR 200.458.

4.3. **Return of Grant Funds.** Grantee must liquidate all Obligations incurred under the Award within forty-five (45) days of the end of the Period of Performance, or in the case of capital improvement Awards, within forty-five (45) days of the end of the time period the Grant Funds are available for expenditure or obligation, unless Grantor permits a longer period in **PART TWO OR PART THREE**.

4.4. **Cash Management Improvement Act of 1990.** Unless notified otherwise in **PART TWO or PART THREE**, Grantee must manage federal funds received under this Agreement in accordance with the Cash Management Improvement Act of 1990 (31 USC 6501 *et seq.*) and any other applicable federal laws or regulations. 2 CFR 200.305; 44 Ill. Admin. Code 7000.120.

4.5. **Payments to Third Parties.** Grantor will have no liability to Grantee when Grantor acts in good faith to redirect all or a portion of any Grantee payment to a third party. Grantor will be deemed to have acted in good faith when it is in possession of information that indicates Grantee authorized Grantor to intercept or redirect payments to a third party or when so ordered by a court of competent jurisdiction.

4.6. **Modifications to Estimated Amount.** If the Agreement amount is established on an estimated basis, then it may be increased by mutual agreement at any time during the Term. Grantor may decrease the estimated amount of this Agreement at any time during the Term if (i) Grantor believes Grantee will not use the funds during the Term, (ii) Grantor believes Grantee has used Grant Funds in a manner that was not authorized by this Agreement, (iii) sufficient funds for this Agreement have not been appropriated or otherwise made available to Grantor by the State or the federal funding source, (iv) the Governor or Grantor reserves funds, or (v) the Governor or Grantor determines that funds will or may not be available for payment. Grantee will be notified, in writing, of any adjustment of the estimated amount of this Agreement. In the event of such reduction, services provided by Grantee under **Exhibit A** may be reduced accordingly. Grantor must pay Grantee for work satisfactorily performed prior to the date of the notice regarding adjustment. 2 CFR 200.308.

4.7. **Interest.**

(a) All interest earned on Grant Funds held by a Grantee will be treated in accordance with 2 CFR 200.305(b)(9), unless otherwise provided in **PART TWO** or **PART THREE**. Grantee must remit annually any amount due in accordance with 2 CFR 200.305(b)(9) or to Grantor, as applicable.

(b) Grant Funds must be placed in an insured account, whenever possible, that bears interest, unless exempted under 2 CFR 200.305(b)(8).

4.8. **Timely Billing Required.** Grantee must submit any payment request to Grantor within fifteen (15) days of the end of the quarter, unless another billing schedule is specified in **ARTICLE II, PART TWO**, or **PART THREE**. Failure to submit such payment request timely will render the amounts billed Unallowable Costs which Grantor cannot reimburse. In the event that Grantee is unable, for good cause, to submit its payment request timely, Grantee shall timely notify Grantor and may request an extension of time to submit the payment request. Grantor's approval of Grantee's request for an extension shall not be unreasonably withheld.

4.9. **Certification.** Pursuant to 2 CFR 200.415, each invoice and report submitted by Grantee (or subrecipient) must contain the following certification by an official authorized to legally bind Grantee (or subrecipient):

By signing this report [or payment request or both], I certify to the best of my knowledge and belief that the report [or payment request] is true, complete, and accurate; that the expenditures, disbursements and cash receipts are for the purposes and objectives set forth in the terms and conditions of the State or federal pass-through award; and that supporting documentation has been submitted as required by the grant agreement. I acknowledge that approval for any other expenditure described herein is considered conditional subject to further review and verification in accordance with the monitoring and records retention provisions of the grant agreement. I am aware that any false, fictitious, or fraudulent information, or the omission of any material fact, may subject me to criminal, civil or administrative penalties for fraud, false statements, false claims or otherwise (U.S. Code Title 18, Section 1001 and Title 31, Sections 3729-3730 and 3801-3812; 30 ILCS 708/120).

ARTICLE V SCOPE OF AWARD ACTIVITIES/PURPOSE OF AWARD

5.1. **Scope of Award Activities/Purpose of Award.** Grantee must perform as described in this Agreement, including as described in **Exhibit A** (Project Description), **Exhibit B** (Deliverables or Milestones), and **Exhibit D** (Performance Measures and Standards), as applicable. Grantee must further comply with all terms and conditions set forth in the Notice of State Award (44 Ill. Admin. Code 7000.360) which is incorporated herein by reference. All Grantor-specific provisions and programmatic reporting required under this Agreement are described in **PART TWO** (Grantor-Specific Terms). All Project-specific provisions and reporting required under this Agreement are described in **PART THREE** (Project-Specific Terms).

5.2. **Scope Revisions.** Grantee must obtain Prior Approval from Grantor whenever a scope revision is necessary for one or more of the reasons enumerated in 44 Ill. Admin. Code 7000.370(b)(2). All requests for scope revisions that require Grantor approval must be signed by Grantee's authorized representative and submitted to Grantor for approval. Expenditure of funds under a requested revision is prohibited and will not be reimbursed if expended before Grantor gives written approval. 2 CFR 200.308.

5.3. Specific Conditions. If applicable, specific conditions required after a risk assessment are included in **Exhibit E**. Grantee must adhere to the specific conditions listed therein. 44 Ill. Admin. Code 7000.340(e).

ARTICLE VI BUDGET

6.1. Budget. The Budget submitted by Grantee at application, or a revised Budget subsequently submitted and approved by Grantor, is considered final and is incorporated herein by reference.

6.2. Budget Revisions. Grantee must obtain Prior Approval, whether mandated or discretionary, from Grantor whenever a Budget revision, is necessary for one or more of the reasons enumerated in 44 Ill. Admin. Code 7000.370(b). All requests for Budget revisions that require Grantor approval must be signed by Grantee's authorized representative and submitted to Grantor for approval. Expenditure of funds under a requested revision is prohibited and will not be reimbursed if expended before Grantor gives written approval.

6.3. Notification. Within thirty (30) calendar days from the date of receipt of the request for Budget revisions, Grantor will review the request and notify Grantee whether the Budget revision has been approved, denied, or the date upon which a decision will be reached. 44 Ill. Admin. Code 7000.370(b)(7).

ARTICLE VII ALLOWABLE COSTS

7.1. Allowability of Costs; Cost Allocation Methods. The allowability of costs and cost allocation methods for work performed under this Agreement will be determined in accordance with 2 CFR Part 200 Subpart E and Appendices III, IV, V, and VII.

7.2. Indirect Cost Rate Submission.

(a) All grantees, except for Local Education Agencies (as defined in 34 CFR 77.1), must make an Indirect Cost Rate election in the Grantee Portal, even grantees that do not charge or expect to charge Indirect Costs. 44 Ill. Admin. Code 7000.420(e).

(i) Waived and de minimis Indirect Cost Rate elections will remain in effect until Grantee elects a different option.

(b) Grantee must submit an Indirect Cost Rate Proposal in accordance with federal and State regulations, in a format prescribed by Grantor. For grantees who have never negotiated an Indirect Cost Rate before, the Indirect Cost Rate Proposal must be submitted for approval no later than three months after the effective date of the Award. For grantees who have previously negotiated an Indirect Cost Rate, the Indirect Cost Rate Proposal must be submitted for approval within 180 days of Grantee's fiscal year end, as dictated in the applicable appendices, such as:

(i) Appendix VII to 2 CFR Part 200 governs Indirect Cost Rate Proposals for state and Local Governments and Indian Tribes,

(ii) Appendix III to 2 CFR Part 200 governs Indirect Cost Rate Proposals for public and private institutions of higher education,

(iii) Appendix IV to 2 CFR Part 200 governs Indirect (F&A) Costs Identification and Assignment, and Rate Determination for Nonprofit Organizations, and

(iv) Appendix V to 2 CFR Part 200 governs state/Local Governmentwide Central Service Cost Allocation Plans.

(c) A grantee who has a current, applicable rate negotiated by a cognizant federal agency must provide to Grantor a copy of its Indirect Cost Rate acceptance letter from the federal government and a copy of all documentation regarding the allocation methodology for costs used to negotiate that rate, e.g., without limitation, the cost policy statement or disclosure narrative statement. Grantor will accept that Indirect Cost Rate, up to any statutory, rule-based or programmatic limit.

(d) A grantee who does not have a current negotiated rate, may elect to charge a de minimis rate of 10% of Modified Total Direct Cost which may be used indefinitely. No documentation is required to justify the 10% de minimis Indirect Cost Rate. 2 CFR 200.414(f).

7.3. **Transfer of Costs.** Cost transfers between Grants, whether as a means to compensate for cost overruns or for other reasons, are unallowable. 2 CFR 200.451.

7.4. **Commercial Organization Cost Principles.** The federal cost principles and procedures for cost analysis and the determination, negotiation and allowance of costs that apply to commercial organizations are set forth in 48 CFR Part 31.

7.5. **Financial Management Standards.** The financial management systems of Grantee must meet the following standards:

(a) **Accounting System.** Grantee organizations must have an accounting system that provides accurate, current, and complete disclosure of all financial transactions related to each state- and federally-funded Program. Accounting records must contain information pertaining to State and federal pass-through awards, authorizations, Obligations, unobligated balances, assets, outlays, and income. These records must be maintained on a current basis and balanced at least quarterly. Cash contributions to the Program from third parties must be accounted for in the general ledger with other Grant Funds. Third party in-kind (non-cash) contributions are not required to be recorded in the general ledger, but must be under accounting control, possibly through the use of a memorandum ledger. To comply with 2 CFR 200.305(b)(7)(i) and 30 ILCS 708/97, Grantee must use reasonable efforts to ensure that funding streams are delineated within Grantee's accounting system. 2 CFR 200.302.

(b) **Source Documentation.** Accounting records must be supported by such source documentation as canceled checks, bank statements, invoices, paid bills, donor letters, time and attendance records, activity reports, travel reports, contractual and consultant agreements, and subaward documentation. All supporting documentation must be clearly identified with the Award and general ledger accounts which are to be charged or credited.

(i) The documentation standards for salary charges to Grants are prescribed by 2 CFR 200.430, and in the cost principles applicable to the Grantee's organization.

(ii) If records do not meet the standards in 2 CFR 200.430, then Grantor may notify Grantee in **PART TWO, PART THREE** or **Exhibit E** of the requirement to submit personnel activity reports. 2 CFR 200.430(i)(8). Personnel activity reports must account on an after-the-fact basis for one hundred percent (100%) of the employee's actual time, separately indicating the time spent on the Award, other grants or projects, vacation or sick leave, and administrative time, if applicable. The reports must be signed by the employee, approved by the appropriate official, and coincide with a pay period. These time records must be used to record the distribution of salary costs to the appropriate accounts no less frequently than quarterly.

(iii) Formal agreements with independent contractors, such as consultants, must include a description of the services to be performed, the period of performance, the fee and method of payment, an itemization of travel and other costs which are chargeable to the agreement, and the signatures of both the contractor and an appropriate official of Grantee.

(iv) If third party in-kind (non-cash) contributions are used for Award purposes, the valuation of these contributions must be supported with adequate documentation.

(c) **Internal Control.** Grantee must maintain effective control and accountability for all cash, real and personal property, and other assets. Grantee must adequately safeguard all such property and must provide assurance that it is used solely for authorized purposes. Grantee must also have systems in place that provide reasonable assurance that the information is accurate, allowable, and compliant with the terms and conditions of this Agreement. 2 CFR 200.303.

(d) **Budget Control.** Grantee must maintain records of expenditures for each Award by the cost categories of the approved Budget (including Indirect Costs that are charged to the Award), and actual expenditures are to be compared with budgeted amounts at least quarterly.

(e) **Cash Management.** Requests for advance payment must be limited to Grantee's immediate cash needs. Grantee must have written procedures to minimize the time elapsing between the receipt and the disbursement of Grant Funds to avoid having excess funds on hand. 2 CFR 200.305.

7.6. **Profits.** It is not permitted for any person or entity to earn a Profit from an Award. *See, e.g.,* 2 CFR 200.400(g); *see also* 30 ILCS 708/60(a)(7).

7.7. **Management of Program Income.** Grantee is encouraged to earn income to defray Program Costs where appropriate, subject to 2 CFR 200.307.

ARTICLE VIII LOBBYING

8.1. **Improper Influence.** Grantee certifies that it will not use and has not used Grant Funds to influence or attempt to influence an officer or employee of any government agency or a member or employee of the State or federal legislature in connection with the awarding of any agreement, the making of any grant, the making of any loan, the entering into of any cooperative agreement, or the extension, continuation, renewal, amendment or modification of any agreement, grant, loan or cooperative agreement. Additionally, Grantee certifies that it has filed the required certification under the Byrd Anti-Lobbying Amendment (31 USC 1352), if applicable.

8.2. **Federal Form LLL.** If any federal funds, other than federally-appropriated funds, were paid or will be paid to any person for influencing or attempting to influence any of the above persons in connection with this Agreement, the undersigned must also complete and submit Federal Form LLL, Disclosure of Lobbying Activities Form, in accordance with its instructions.

8.3. **Lobbying Costs.** Grantee certifies that it is in compliance with the restrictions on lobbying set forth in 2 CFR 200.450. For any Indirect Costs associated with this Agreement, total lobbying costs must be separately identified in the Program Budget, and thereafter treated as other Unallowable Costs.

8.4. **Procurement Lobbying.** Grantee warrants and certifies that it and, to the best of its knowledge, its subrecipients have complied and will comply with Illinois Executive Order No. 1 (2007) (EO 1-2007). EO 1-2007

generally prohibits grantees and subcontractors from hiring the then-serving Governor's family members to lobby procurement activities of the State, or any other unit of government in Illinois including local governments, if that procurement may result in a contract valued at over \$25,000. This prohibition also applies to hiring for that same purpose any former State employee who had procurement authority at any time during the one-year period preceding the procurement lobbying activity.

8.5. **Subawards.** Grantee must include the language of this ARTICLE in the award documents for any subawards made pursuant to this Award at all tiers. All subrecipients are also subject to certification and disclosure. Pursuant to Appendix II(I) to 2 CFR Part 200, Grantee must forward all disclosures by contractors regarding this certification to Grantor.

8.6. **Certification.** This certification is a material representation of fact upon which reliance was placed to enter into this transaction and is a prerequisite for this transaction, pursuant to 31 USC 1352. Any person who fails to file the required certifications will be subject to a civil penalty of not less than \$10,000, and not more than \$100,000, for each such failure.

ARTICLE IX MAINTENANCE AND ACCESSIBILITY OF RECORDS; MONITORING

9.1. **Records Retention.** Grantee must maintain for three (3) years from the date of submission of the final expenditure report, adequate books, all financial records and, supporting documents, statistical records, and all other records pertinent to this Award, adequate to comply with 2 CFR 200.334, unless a different retention period is specified in 2 CFR 200.334, 44 Ill. Admin. Code 7000.430(a) and (b) or **PART TWO** or **PART THREE**. If any litigation, claim or audit is started before the expiration of the retention period, the records must be retained until all litigation, claims or audit exceptions involving the records have been resolved and final action taken.

9.2. **Accessibility of Records.** Grantee, in compliance with 2 CFR 200.337 and 44 Ill. Admin. Code 7000.430(f), must make books, records, related papers, supporting documentation and personnel relevant to this Agreement available to authorized Grantor representatives, the Illinois Auditor General, Illinois Attorney General, any Executive Inspector General, Grantor's Inspector General, federal authorities, any person identified in 2 CFR 200.337, and any other person as may be authorized by Grantor (including auditors), by the State of Illinois or by federal statute. Grantee must cooperate fully in any such audit or inquiry.

9.3. **Failure to Maintain Books and Records.** Failure to maintain books, records and supporting documentation, as described in this ARTICLE, establishes a presumption in favor of the State for the recovery of any Grant Funds paid by the State under this Agreement for which adequate books, records and supporting documentation are not available to support disbursement.

9.4. **Monitoring and Access to Information.** Grantee must monitor its activities to assure compliance with applicable state and federal requirements and to assure its performance expectations are being achieved. Grantor will monitor the activities of Grantee to assure compliance with all requirements and performance expectations of the Award. Grantee must timely submit all financial and performance reports, and must supply, upon Grantor's request, documents and information relevant to the Award. Grantor may make site visits as warranted by Program needs. 2 CFR 200.329; 200.332. Additional monitoring requirements may be in **PART TWO** or **PART THREE**.

ARTICLE X FINANCIAL REPORTING REQUIREMENTS

10.1. **Required Periodic Financial Reports.** Grantee must submit financial reports as requested and in the format required by Grantor no later than the dues date(s) specified in **PART TWO** or **PART THREE**. Grantee must submit quarterly reports with Grantor describing the expenditure(s) of the funds related thereto, unless more frequent reporting is required by the Grantee due to the funding source or pursuant to specific award conditions. 2 CFR 200.208. Any report required by 30 ILCS 708/125 may be detailed in **PART TWO** or **PART THREE**.

10.2. **Financial Close-out Report.**

(a) Grantee must submit a financial Close-out Report, in the format required by Grantor, by the due date specified in **PART TWO** or **PART THREE**, which must be no later than sixty (60) calendar days following the end of the Period of Performance for this Agreement or Agreement termination. The format of this financial Close-out Report must follow a format prescribed by Grantor. 2 CFR 200.344; 44 Ill. Admin. Code 7000.440(b).

(b) If an audit or review of Grantee occurs and results in adjustments after Grantee submits a Close-out Report, Grantee must submit a new financial Close-out Report based on audit adjustments, and immediately submit a refund to Grantor, if applicable. 2 CFR 200.345; 44 Ill. Admin. Code 7000.450.

10.3. **Effect of Failure to Comply.** Failure to comply with the reporting requirements in this Agreement may cause a delay or suspension of funding or require the return of improper payments or Unallowable Costs, and will be considered a material breach of this Agreement. Grantee's failure to comply with ARTICLE X, ARTICLE XI, or ARTICLE XVII will be considered prima facie evidence of a breach and may be admitted as such, without further proof, into evidence in an administrative proceeding before Grantor, or in any other legal proceeding. Grantee should refer to the State Grantee Compliance Enforcement System for policy and consequences for failure to comply. 44 Ill. Admin. Code 7000.80.

ARTICLE XI PERFORMANCE REPORTING REQUIREMENTS

11.1. **Required Periodic Performance Reports.** Grantee must submit performance reports as requested and in the format required by Grantor no later than the due date(s) specified in **PART TWO** or **PART THREE**. 44 Ill. Admin. Code 7000.410. Grantee must report to Grantor on the performance measures listed in **Exhibit D, PART TWO** or **PART THREE** at the intervals specified by Grantor, which must be no less frequent than annually and no more frequent than quarterly, unless otherwise specified in **PART TWO, PART THREE, or Exhibit E** pursuant to specific award conditions. For certain construction-related Awards, such reports may be exempted as identified in **PART TWO** or **PART THREE**. 2 CFR 200.329.

11.2. **Performance Close-out Report.** Grantee must submit a performance Close-out Report, in the format required by Grantor by the due date specified in **PART TWO** or **PART THREE**, which must be no later than 60 calendar days following the end of the Period of Performance or Agreement termination. 2 CFR 200.344; 44 Ill. Admin. Code 7000.440(b).

11.3. **Content of Performance Reports.** Pursuant to 2 CFR 200.329(b) and (c), all performance reports must relate the financial data and accomplishments to the performance goals and objectives of this Award and also include the following: a comparison of actual accomplishments to the objectives of the Award established for the period; where the accomplishments can be quantified, a computation of the cost and demonstration of cost effective practices (e.g., through unit cost data); performance trend data and analysis if required; and reasons

why established goals were not met, if appropriate. Additional content and format guidelines for the performance reports will be determined by Grantor contingent on the Award's statutory, regulatory and administrative requirements, and are included in **PART TWO** or **PART THREE** of this Agreement.

**ARTICLE XII
AUDIT REQUIREMENTS**

12.1. **Audits.** Grantee is subject to the audit requirements contained in the Single Audit Act Amendments of 1996 (31 USC 7501-7507), Subpart F of 2 CFR Part 200, and the audit rules and policies set forth by the Governor's Office of Management and Budget. 30 ILCS 708/65(c); 44 Ill. Admin. Code 7000.90.

12.2. **Consolidated Year-End Financial Reports (CYEFR).** All grantees must complete and submit a CYEFR through the Grantee Portal, except those exempted by federal or State statute or regulation, as set forth in **PART TWO** or **PART THREE**. The CYEFR is a required schedule in Grantee's audit report if Grantee is required to complete and submit an audit report as set forth herein.

(a) Grantee's CYEFR must cover the same period as the audited financial statements, if required, and must be submitted in accordance with the audit schedule at 44 Ill. Admin. Code 7000.90. If Grantee is not required to complete audited financial statements, the CYEFR must cover Grantee's fiscal year and must be submitted within 6 months of the Grantee's fiscal year-end.

(b) The CYEFR must include an in relation to opinion from the auditor of the financial statements included in the audit.

(c) The CYEFR must follow a format prescribed by Grantor.

12.3. **Entities That Are Not "For-Profit".**

(a) This Paragraph applies to Grantees that are not "for-profit" entities.

(b) **Single and Program-Specific Audits.** If, during its fiscal year, Grantee expends \$750,000 or more in federal Awards (direct federal and federal pass-through awards combined), Grantee must have a single audit or program-specific audit conducted for that year as required by 2 CFR 200.501 and other applicable sections of Subpart F of 2 CFR Part 200. The audit report packet must be completed as described in 2 CFR 200.512 (single audit) or 2 CFR 200.507 (program-specific audit), 44 Ill. Admin. Code 7000.90(h)(1) and the current GATA audit manual and submitted to the Federal Audit Clearinghouse, as required by 2 CFR 200.512. The results of peer and external quality control reviews, management letters issued by the auditors and their respective corrective action plans if significant deficiencies or material weaknesses are identified, and the CYEFR(s) must be submitted to the Grantee Portal. The due date of all required submissions set forth in this Paragraph is the earlier of (i) thirty (30) calendar days after receipt of the auditor's report(s) or (ii) nine (9) months after the end of Grantee's audit period.

(c) **Financial Statement Audit.** If, during its fiscal year, Grantee expends less than \$750,000 in federal Awards, Grantee is subject to the following audit requirements:

(i) If, during its fiscal year, Grantee expends \$500,000 or more in State-issued Awards, Grantee must have a financial statement audit conducted in accordance with the Generally Accepted Government Auditing Standards (GAGAS). Grantee may be subject to additional requirements in **PART TWO**, **PART THREE** or **Exhibit E** based on Grantee's risk profile.

(ii) If, during its fiscal year, Grantee expends less than \$500,000 in State-issued Awards, but expends \$300,000 or more in State-issued Awards, Grantee must have a financial statement audit conducted in accordance with the Generally Accepted Auditing Standards (GAAS).

(iii) If Grantee is a Local Education Agency (as defined in 34 CFR 77.1), Grantee must have a financial statement audit conducted in accordance with GAGAS, as required by 23 Ill. Admin. Code 100.110, regardless of the dollar amount of expenditures of State-issued Awards.

(iv) If Grantee does not meet the requirements in subsections 12.3(b) and 12.3(c)(i-iii) but is required to have a financial statement audit conducted based on other regulatory requirements, Grantee must submit those audits for review.

(v) Grantee must submit its financial statement audit report packet, as set forth in 44 Ill. Admin. Code 7000.90(h)(2) and the current GATA audit manual, to the Grantee Portal within the earlier of (i) thirty (30) calendar days after receipt of the auditor's report(s) or (ii) six (6) months after the end of Grantee's audit period.

12.4. "For-Profit" Entities.

(a) This Paragraph applies to Grantees that are "for-profit" entities.

(b) Program-Specific Audit. If, during its fiscal year, Grantee expends \$750,000 or more in federal pass-through funds from State-issued Awards, Grantee must have a program-specific audit conducted in accordance with 2 CFR 200.507. The auditor must audit federal pass-through programs with federal pass-through Awards expended that, in the aggregate, cover at least 50 percent (0.50) of total federal pass-through Awards expended. The audit report packet must be completed as described in 2 CFR 200.507 (program-specific audit), 44 Ill. Admin. Code 7000.90 and the current GATA audit manual, and must be submitted to the Grantee Portal. The due date of all required submissions set forth in this Paragraph is the earlier of (i) thirty (30) calendar days after receipt of the auditor's report(s) or (ii) nine (9) months after the end of Grantee's audit period.

(c) Financial Statement Audit. If, during its fiscal year, Grantee expends less than \$750,000 in federal pass-through funds from State-issued Awards, Grantee must follow all of the audit requirements in Paragraphs 12.3(c)(i)-(v), above.

(d) Publicly-Traded Entities. If Grantee is a publicly-traded company, Grantee is not subject to the single audit or program-specific audit requirements, but must submit its annual audit conducted in accordance with its regulatory requirements.

12.5. Performance of Audits. For those organizations required to submit an independent audit report, the audit must be conducted by the Illinois Auditor General (as required for certain governmental entities only), or a Certified Public Accountant or Certified Public Accounting Firm licensed in the State of Illinois or in accordance with Section 5.2 of the Illinois Public Accounting Act (225 ILCS 450/5.2). For all audits required to be performed subject to GAGAS or Generally Accepted Auditing Standards, Grantee must request and maintain on file a copy of the auditor's most recent peer review report and acceptance letter. Grantee must follow procedures prescribed by Grantor for the preparation and submission of audit reports and any related documents.

12.6. Delinquent Reports. When audit reports or financial statements required under this ARTICLE are prepared by the Illinois Auditor General, if they are not available by the above-specified due date, they must be provided to Grantor within thirty (30) days of becoming available. Grantee should refer to the State Grantee Compliance Enforcement System for the policy and consequences for late reporting. 44 Ill. Admin. Code 7000.80.

**ARTICLE XIII
TERMINATION; SUSPENSION; NON-COMPLIANCE**

13.1. Termination.

(a) Either Party may terminate this Agreement, in whole or in part, upon thirty (30) calendar days' prior written notice to the other Party.

(b) If terminated by the Grantee, Grantee must include the reasons for such termination, the effective date, and, in the case of a partial termination, the portion to be terminated. If Grantor determines in the case of a partial termination that the reduced or modified portion of the Award will not accomplish the purposes for which the Award was made, Grantor may terminate the Agreement in its entirety. 2 CFR 200.340(a)(4).

(c) This Agreement may be terminated, in whole or in part, by Grantor:

(i) Pursuant to a funding failure under Paragraph 4.1;

(ii) If Grantee fails to comply with the terms and conditions of this or any Award, application or proposal, including any applicable rules or regulations, or has made a false representation in connection with the receipt of this or any Award; or

(iii) If the Award no longer effectuates the Program goals or agency priorities as set forth in Exhibit A, PART TWO or PART THREE.

13.2. Suspension. Grantor may suspend this Agreement, in whole or in part, pursuant to a funding failure under Paragraph 4.1 or if the Grantee fails to comply with terms and conditions of this or any Award. If suspension is due to Grantee's failure to comply, Grantor may withhold further payment and prohibit Grantee from incurring additional Obligations pending corrective action by Grantee or a decision to terminate this Agreement by Grantor. Grantor may allow necessary and proper costs that Grantee could not reasonably avoid during the period of suspension.

13.3. Non-compliance. If Grantee fails to comply with the U.S. Constitution, applicable statutes, regulations or the terms and conditions of this or any Award, Grantor may impose additional conditions on Grantee, as described in 2 CFR 200.208. If Grantor determines that non-compliance cannot be remedied by imposing additional conditions, Grantor may take one or more of the actions described in 2 CFR 200.339. The Parties must follow all Grantor policies and procedures regarding non-compliance, including, but not limited to, the procedures set forth in the State Grantee Compliance Enforcement System. 44 Ill. Admin. Code 7000.80 and 7000.260.

13.4. Objection. If Grantor suspends or terminates this Agreement, in whole or in part, for cause, or takes any other action in response to Grantee's non-compliance, Grantee may avail itself of any opportunities to object and challenge such suspension, termination or other action by Grantor in accordance with any applicable processes and procedures, including, but not limited to, the procedures set forth in the State Grantee Compliance Enforcement System. 2 CFR 200.342; 44 Ill. Admin. Code 7000.80 and 7000.260.

13.5. Effects of Suspension and Termination.

(a) Grantor may credit Grantee for allowable expenditures incurred in the performance of authorized services under this Agreement prior to the effective date of a suspension or termination.

(b) Except as set forth in subparagraph (c), below, Grantee must not incur any costs or Obligations that require the use of Grant Funds after the effective date of a suspension or termination, and must cancel as many outstanding Obligations as possible.

(c) Costs to Grantee resulting from Obligations incurred by Grantee during a suspension or after termination of the Agreement are not allowable unless Grantor expressly authorizes them in the notice of suspension or termination or subsequently. However, Grantor may allow costs during a suspension or after termination if:

(i) The costs result from Obligations properly incurred before the effective date of suspension or termination, are not in anticipation of the suspension or termination, and the costs would be allowable if the Agreement was not suspended or terminated prematurely. 2 CFR 200.343.

13.6. Close-out of Terminated Agreements. If this Agreement is terminated, in whole or in part, the Parties must comply with all close-out and post-termination requirements of this Agreement. 2 CFR 200.340(d).

ARTICLE XIV SUBCONTRACTS/SUBAWARDS

14.1. Subcontracting/Subrecipients/Delegation. Grantee must not subcontract nor issue a subaward for any portion of this Agreement nor delegate any duties hereunder without Prior Approval of Grantor. The requirement for Prior Approval is satisfied if the subcontractor or subrecipient has been identified in the uniform grant application, such as, without limitation, a Project description, and Grantor has approved. Grantee must notify any potential subrecipient that the subrecipient must obtain and provide to the Grantee a Unique Entity Identifier prior to receiving a subaward. 2 CFR 25.300.

14.2. Application of Terms. If Grantee enters into a subaward agreement with a subrecipient, Grantee must notify the subrecipient of the applicable laws and regulations and terms and conditions of this Award by attaching this Agreement to the subaward agreement. The terms of this Agreement apply to all subawards authorized in accordance with Paragraph 14.1. 2 CFR 200.101(b)(2).

14.3. Liability as Guaranty. Grantee will be liable as guarantor for any Grant Funds it obligates to a subrecipient or subcontractor pursuant to this ARTICLE in the event Grantor determines the funds were either misspent or are being improperly held and the subrecipient or subcontractor is insolvent or otherwise fails to return the funds. 2 CFR 200.345; 30 ILCS 705/6; 44 Ill. Admin. Code 7000.450(a).

ARTICLE XV NOTICE OF CHANGE

15.1. Notice of Change. Grantee must notify Grantor if there is a change in Grantee's legal status, FEIN, UEI, SAM registration status, Related Parties, senior management (for non-governmental grantees only) or address. If the change is anticipated, Grantee must give thirty (30) days' prior written notice to Grantor. If the change is unanticipated, Grantee must give notice as soon as practicable thereafter. Grantor reserves the right to take any and all appropriate action as a result of such change(s).

15.2. **Failure to Provide Notification.** To the extent permitted by Illinois law (see Paragraph 21.2), Grantee must hold harmless Grantor for any acts or omissions of Grantor resulting from Grantee's failure to notify Grantor as required by Paragraph 15.1.

15.3. **Notice of Impact.** Grantee must notify Grantor in writing of any event, including, by not limited to, becoming a party to litigation, an investigation, or transaction that may have a material impact on Grantee's ability to perform under this Agreement. Grantee must provide notice to Grantor as soon as possible, but no later than five (5) days after Grantee becomes aware that the event may have a material impact.

15.4. **Effect of Failure to Provide Notice.** Failure to provide the notice described in this ARTICLE is grounds for termination of this Agreement and any costs incurred after the date notice should have been given may be disallowed.

ARTICLE XVI STRUCTURAL REORGANIZATION AND RECONSTITUTION OF BOARD MEMBERSHIP

16.1. **Effect of Reorganization.** This Agreement is made by and between Grantor and Grantee, as Grantee is currently organized and constituted. Grantor does not agree to continue this Agreement, or any license related thereto, should Grantee significantly reorganize or otherwise substantially change the character of its corporate structure, business structure or governance structure. Grantee must give Grantor prior notice of any such action or changes significantly affecting its overall structure or, for non-governmental grantees only, management makeup (for example, a merger or a corporate restructuring), and must provide all reasonable documentation necessary for Grantor to review the proposed transaction including financial records and corporate and shareholder minutes of any corporation which may be involved. Grantor reserves the right to terminate the Agreement based on whether the newly organized entity is able to carry out the requirements of the Award. This ARTICLE does not require Grantee to report on minor changes in the makeup of its board membership or governance structure, as applicable. Nevertheless, **PART TWO** or **PART THREE** may impose further restrictions. Failure to comply with this ARTICLE constitutes a material breach of this Agreement.

ARTICLE XVII CONFLICT OF INTEREST

17.1. **Required Disclosures.** Grantee must immediately disclose in writing any potential or actual Conflict of Interest to Grantor. 2 CFR 200.113; 30 ILCS 708/35.

17.2. **Prohibited Payments.** Payments made by Grantor under this Agreement must not be used by Grantee to compensate, directly or indirectly, any person currently holding an elective office in this State including, but not limited to, a seat in the General Assembly. In addition, where Grantee is not an instrumentality of the State of Illinois, as described in this Paragraph, Grantee must request permission from Grantor to compensate, directly or indirectly, any person employed by an office or agency of the State of Illinois. An instrumentality of the State of Illinois includes, without limitation, State departments, agencies, boards, and State universities. An instrumentality of the State of Illinois does not include, without limitation, units of Local Government and related entities.

17.3. **Request for Exemption.** Grantee may request written approval from Grantor for an exemption from Paragraph 17.2. Grantee acknowledges that Grantor is under no obligation to provide such exemption and that Grantor may grant an such exemption subject to additional terms and conditions as Grantor may require.

**ARTICLE XVIII
EQUIPMENT OR PROPERTY**

18.1. Purchase of Equipment. For any equipment purchased in whole or in part with Grant Funds, if Grantor determines that Grantee has not met the conditions of 2 CFR 200.439, the costs for such equipment will be disallowed. Grantor must notify Grantee in writing that the purchase of equipment is disallowed.

18.2. Prohibition against Disposition/Encumbrance. Any equipment, material, or real property that Grantee purchases or improves with Grant Funds must not be sold, transferred, encumbered (other than original financing) or otherwise disposed of during the Award Term without Prior Approval of Grantor unless a longer period is required in **PART TWO** or **PART THREE** and permitted by 2 CFR Part 200 Subpart D. Use or disposition of real property acquired or improved using Grant Funds must comply with the requirements of 2 CFR 200.311. Real property, equipment, and intangible property that are acquired or improved in whole or in part using Grant Funds are subject to the provisions of 2 CFR 200.316. Grantor may require the Grantee to record liens or other appropriate notices of record to indicate that personal or real property has been acquired or improved with this Award and that use and disposition conditions apply to the property.

18.3. Equipment and Procurement. Grantee must comply with the uniform standards set forth in 2 CFR 200.310–200.316 governing the management and disposition of property, the cost of which was supported by Grant Funds. Any waiver from such compliance must be granted by either the President’s Office of Management and Budget, the Governor’s Office of Management and Budget, or both, depending on the source of the Grant Funds used. Additionally, Grantee must comply with the standards set forth in 2 CFR 200.317-200.326 to establish procedures to use Grant Funds for the procurement of supplies and other expendable property, equipment, real property and other services.

18.4. Equipment Instructions. Grantee must obtain disposition instructions from Grantor when equipment, purchased in whole or in part with Grant Funds, is no longer needed for their original purpose. Notwithstanding anything to the contrary contained in this Agreement, Grantor may require transfer of any equipment to Grantor or a third party for any reason, including, without limitation, if Grantor terminates the Award or Grantee no longer conducts Award activities. Grantee must properly maintain, track, use, store and insure the equipment according to applicable best practices, manufacturer’s guidelines, federal and state laws or rules, and Grantor requirements stated herein.

18.5. Domestic Preferences for Procurements. In accordance with 2 CFR 200.322, as appropriate and to the extent consistent with law, Grantee must, to the greatest extent practicable under this Award, provide a preference for the purchase, acquisition, or use of goods, products, or materials produced in the United States (including but not limited to iron, aluminum, steel, cement, and other manufactured products). The requirements of this Paragraph must be included in all subawards and in all contracts and purchase orders for work or products under this Award.

**ARTICLE XIX
PROMOTIONAL MATERIALS; PRIOR NOTIFICATION**

19.1. Promotional and Written Materials. Use of Grant Funds for promotions is subject to the prohibitions for advertising or public relations costs in 2 CFR 200.421(e). In the event that Grant Funds are used in whole or in part to produce any written publications, announcements, reports, flyers, brochures or other written materials, Grantee must obtain Prior Approval for the use of those funds (2 CFR 200.467) and must

include in these publications, announcements, reports, flyers, brochures and all other such material, the phrase "Funding provided in whole or in part by the [Grantor]." 2 CFR 200.467. Exceptions to this requirement must be requested, in writing, from Grantor and will be considered authorized only upon written notice thereof to Grantee.

19.2. Prior Notification/Release of Information. Grantee must notify Grantor ten (10) days prior to issuing public announcements or press releases concerning work performed pursuant to this Agreement, or funded in whole or in part by this Agreement, and must cooperate with Grantor in joint or coordinated releases of information.

**ARTICLE XX
INSURANCE**

20.1. Maintenance of Insurance. Grantee must maintain in full force and effect during the Term of this Agreement casualty and bodily injury insurance, as well as insurance sufficient to cover the replacement cost of any and all real or personal property, or both, purchased or, otherwise acquired, or improved in whole or in part, with funds disbursed pursuant to this Agreement. 2 CFR 200.310. Additional insurance requirements may be detailed in **PART TWO** or **PART THREE**.

20.2. Claims. If a claim is submitted for real or personal property, or both, purchased in whole with funds from this Agreement and such claim results in the recovery of money, such money recovered must be surrendered to Grantor.

**ARTICLE XXI
LAWSUITS AND INDEMNIFICATION**

21.1. Independent Contractor. Neither Grantee nor any employee or agent of Grantee acquires any employment rights with Grantor by virtue of this Agreement. Grantee must provide the agreed services and achieve the specified results free from the direction or control of Grantor as to the means and methods of performance. Grantee must provide its own equipment and supplies necessary to conduct its business; provided, however, that in the event, for its convenience or otherwise, Grantor makes any such equipment or supplies available to Grantee, Grantee's use of such equipment or supplies provided by Grantor pursuant to this Agreement is strictly limited to official Grantor or State of Illinois business and not for any other purpose, including any personal benefit or gain.

21.2. Indemnification and Liability.

(a) **Non-governmental entities.** This subparagraph applies only if Grantee is a non-governmental entity. Grantee must hold harmless Grantor against any and all liability, loss, damage, cost or expenses, including attorneys' fees, arising from the intentional torts, negligence or breach of contract of Grantee, with the exception of acts performed in conformance with an explicit, written directive of Grantor. Indemnification by Grantor is governed by the State Employee Indemnification Act (5 ILCS 350/.01 *et seq.*) as interpreted by the Illinois Attorney General. Grantor makes no representation that Grantee, an independent contractor, will qualify or be eligible for indemnification under said Act.

(b) **Governmental entities.** This subparagraph applies only if Grantee is a governmental unit as designated in Paragraph 3.2. Neither Party shall be liable for actions chargeable to the other Party under this Agreement including, but not limited to, the negligent acts and omissions of the other Party's

agents, employees or subcontractors in the performance of their duties as described under this Agreement, unless such liability is imposed by law. This Agreement is not construed as seeking to enlarge or diminish any obligation or duty owed by one Party against the other or against a third party.

**ARTICLE XXII
MISCELLANEOUS**

22.1. Gift Ban. Grantee is prohibited from giving gifts to State employees pursuant to the State Officials and Employees Ethics Act (5 ILCS 430/10-10) and Illinois Executive Order 15-09.

22.2. Assignment Prohibited. This Agreement must not be sold, assigned, or transferred in any manner by Grantee, to include an assignment of Grantee's rights to receive payment hereunder, and any actual or attempted sale, assignment, or transfer by Grantee without the Prior Approval of Grantor in writing renders this Agreement null, void and of no further effect.

22.3. Copies of Agreements upon Request. Grantee must, upon request by Grantor, provide Grantor with copies of contracts or other agreements to which Grantee is a party with any other State agency.

22.4. Amendments. This Agreement may be modified or amended at any time during its Term by mutual consent of the Parties, expressed in writing and signed by the Parties.

22.5. Severability. If any provision of this Agreement is declared invalid, its other provisions will remain in effect.

22.6. No Waiver. The failure of either Party to assert any right or remedy pursuant to this Agreement will not be construed as a waiver of either Party's right to assert such right or remedy at a later time or constitute a course of business upon which either Party may rely for the purpose of denial of such a right or remedy.

22.7. Applicable Law; Claims. This Agreement and all subsequent amendments thereto, if any, are governed and construed in accordance with the laws of the State of Illinois. Any claim against Grantor arising out of this Agreement must be filed exclusively with the Illinois Court of Claims. 705 ILCS 505/1 *et seq.* Grantor does not waive sovereign immunity by entering into this Agreement.

22.8. Compliance with Law. This Agreement and Grantee's Obligations and services hereunder must be performed in compliance with all applicable federal and State laws, including, without limitation, federal regulations, State administrative rules, including but not limited to 44 Ill. Admin. Code Part 7000, laws and rules which govern disclosure of confidential records or other information obtained by Grantee concerning persons served under this Agreement, and any license requirements or professional certification provisions.

22.9. Compliance with Freedom of Information Act. Upon request, Grantee must make available to Grantor all documents in its possession that Grantor deems necessary to comply with requests made under the Freedom of Information Act. 5 ILCS 140/7(2).

22.10. Precedence.

(a) Except as set forth in subparagraph (b), below, the following rules of precedence are controlling for this Agreement: In the event there is a conflict between this Agreement and any of the exhibits or attachments hereto, this Agreement controls. In the event there is a conflict between **PART ONE** and **PART TWO** or **PART THREE** of this Agreement, **PART ONE** controls. In the event there is a conflict

between **PART TWO** and **PART THREE** of this Agreement, **PART TWO** controls. In the event there is a conflict between this Agreement and relevant statute(s) or rule(s), the relevant statute(s) or rule(s) controls.

(b) Notwithstanding the provisions in subparagraph (a), above, if a relevant federal or state statute(s) or rule(s) requires an exception to this Agreement's provisions, or an exception to a requirement in this Agreement is granted by GATU, such exceptions must be noted in **PART TWO** or **PART THREE**, and in such cases, those requirements control.

22.11. **Illinois Grant Funds Recovery Act.** In the event of a conflict between the Illinois Grant Funds Recovery Act and the Grant Accountability and Transparency Act, the provisions of the Grant Accountability and Transparency Act control. 30 ILCS 708/80.

22.12. **Headings.** Articles and other headings contained in this Agreement are for reference purposes only and are not intended to define or limit the scope, extent or intent of this Agreement or any provision hereof.

22.13. **Counterparts.** This Agreement may be executed in one or more counterparts, each of which are considered to be one and the same agreement, binding on all Parties hereto, notwithstanding that all Parties are not signatories to the same counterpart. Duplicated signatures, signatures transmitted via facsimile, or signatures contained in a Portable Document Format (PDF) document are deemed original for all purposes.

22.14. **Attorney Fees and Costs.** Unless prohibited by law, if Grantor prevails in any proceeding to enforce the terms of this Agreement, including any administrative hearing pursuant to the Grant Funds Recovery Act or the Grant Accountability and Transparency Act, Grantor has the right to recover reasonable attorneys' fees, costs and expenses associated with such proceedings.

22.15. **Continuing Responsibilities.** The termination or expiration of this Agreement does not affect: (a) the right of Grantor to disallow costs and recover funds based on a later audit or other review; (b) the obligation of the Grantee to return any funds due as a result of later refunds, corrections or other transactions, including, without limitation, final Indirect Cost Rate adjustments and those funds obligated pursuant to ARTICLE XIV; (c) the CYEFR(s); (d) audit requirements established in 44 Ill. Admin. Code 7000.90 and ARTICLE XII; (e) property management and disposition requirements established in 2 CFR 200.310 through 2 CFR 200.316 and ARTICLE XVIII; or (f) records related requirements pursuant to ARTICLE IX. 44 Ill. Admin. Code 7000.440.

THE REMAINDER OF THIS PAGE IS INTENTIONALLY LEFT BLANK.

EXHIBIT A

PROJECT DESCRIPTION

Project Address: North Island Park is 250 Bridge Street, Wilmington, IL 60481

Scope of Work: The Project consists of a canoe and kayak launch with an accessible, aluminum floating dock system, a gangway, an enhanced asphalt parking lot, and an accessible, concrete path from the parking lot to the launch. The Project will provide accessible river access to the Kankakee River for paddlers.

The Project's two termini are the existing gravel parking lot on N Bridge Street in Wilmington, and the water to the east of the parking lot.

EXHIBIT B

DELIVERABLES OR MILESTONES

This grant is funded through the Boat Access Area Development Grant Program (BAAD). It is funded up to 100% through (BAAD).

The Implementation and Billing Requirement Packet is incorporated into this Agreement by reference.

Project billings shall be submitted within 60 days of project completion unless otherwise approved by IDNR.

Deliverables/Milestones will be the completed project components as presented in the original application or an approved project scope change. They will be reported as directed in the Implementation and Billing Packet.

If the approved (BAAD) project includes the use of Force Account labor, the Grantee shall ensure that any audits required will include an internal control evaluation and opinion on the grantee's time and attendance allocation system. In addition, if the grantee uses materials purchased by means of a Central Procurement System and allocates a portion of those materials to the project (Force Account material claim), the audit must include testing and reporting on the allocation system used for tracking material use.

The Grantee is required to file quarterly status reports on the grant project describing the progress of the program, project, or use and expenditure of the grant funds related thereto, if the grant amount is over \$25,000.00 (30 ILCS 705/4(b)(2)). The grantee must submit status reports on the first day of the next existing quarterly schedule (Jan, April, July & Oct) beginning with the quarter immediately following the project effective date.

EXHIBIT C

CONTACT INFORMATION

CONTACTS FOR NOTIFICATION AND GRANT ADMINISTRATION:

Unless specified elsewhere, all notices required or desired to be sent by either Party must be sent to the persons listed below. Grantee must notify Grantor of any changes in its contact information listed below within five (5) business days from the effective date of the change, and Grantor must notify Grantee of any changes to its contact information as soon as practicable. The Party making a change must send any changes in writing to the contact for the other Party. No amendment to this Agreement is required if information in this Exhibit is changed.

FOR OFFICIAL GRANT NOTIFICATIONS

GRANTOR CONTACT

Name: Stacia McKinney

Title: Conservation Grant Administrator

Address: One Natural Resources Way, Spfld., IL 62702

GRANTEE CONTACT

Name: Jeannine Smith

Title: City Administrator

Address: 1165 S. Water Street, Wilmington, IL 60481

GRANTEE PAYMENT ADDRESS

(If different than the address above)

Address:

FOR GRANT ADMINISTRATION

<u>GRANTOR CONTACT</u>	<u>GRANTEE CONTACT</u>
Name: Stacia McKinney	Name: Jeannine Smith
Title: Conservation Grant Administrator	Title: City Administrator
Address: One Natural Resources Way, Spfld., IL 62702	Address: 1165 S. Water Street, Wilmington, IL 60481
Phone: 217.557.8781	Phone: 815.476.2175 EXT 232
TTY#:	TTY#:
E-mail Address: Stacia.McKinney@illinois.gov	E-mail Address: jsmith@wilmington-il.com

EXHIBIT D

PERFORMANCE MEASURES AND STANDARDS

Following all methods and standards as required by state and federal laws and regulations, this project will make outdoor recreation available to members of the public by accomplishing the following items:

Providing community members with outdoor recreational opportunities that can be utilized by members of the public.

Periodic Performance Report (PPR) that describes the progress of the project, and the Periodic Financial Report (PFR) that documents expenditure of funds in accordance with the budget line items as detailed in the approved Uniform Budget. Below is the required periodic reporting schedule for this Award.

Reporting Period	PPR and PFR Due Date
January 1 – March 31	April 15
April 1 – June 30	July 15
July 1 – September 30	October 15
October 1 – December 31	January 15

Final Project Report. The grantee shall submit a written Final Project Report to the department no later than 30 days following the completion of the Project or the ending date of the grant agreement, whichever is earlier, in accordance with the applicable administrative rules. The final report shall be in the form or format provided by the Department.

Final Project Report shall include but not be limited to the following information:

- Grant agreement number
- Grantee name, address, and telephone number
- Timeframe of the report
- Name and telephone number or e-mail address of grantee representative completing the report
- Project objective as described in the application and grant agreement
- Completed project description
- Summary of the project accomplishments
- Any other information/documentation as required by the Grantor.

Failure to provide the Final Project Report. As required may render the grantee ineligible to receive payments under the current award or make them ineligible for future awards.

EXHIBIT E

SPECIFIC CONDITIONS

Grantor may remove (or reduce) a Specific Condition included in this Exhibit by providing written notice to the Grantee, in accordance with established procedures for removing a Specific Condition.

ICQ Section: 05-Audit

Conditions: Grantee must submit, at least semi-annually, documentation to support the status of implementation of corrective action for audit findings.

Risk Explanation: Medium to high risk will result in repeated audit findings, potential questioned cost, and increase of administrative and programmatic specific conditions that will increase the cost of managing the grant program.

How to Fix: Implementation of grantee's corrective action plan.

Timeframe: When corrective action is complete.

PART TWO –GRANTOR-SPECIFIC TERMS

In addition to the uniform requirements in **PART ONE**, Grantor has the following additional requirements for its Grantee:

**ARTICLE XXIII
AUTHORIZED SIGNATORY**

23.1. Authorized Signatory. The signature of the Authorized Representative for the Grantor on the signature page of this Award is considered the Authorized Signatory for purposes of this Agreement. Any amendments or changes to this Agreement must be approved and signed by the Authorized Signatory.

**ARTICLE XXIV
ILLINOIS WORKS JOBS ACT**

24.1. Illinois Works Jobs Program Act (30 ILCS 559/20-1 et seq.). For grants with an estimated total project cost of \$500,000 or more, the grantee will be required to comply with the Illinois Works Apprenticeship Initiative (30 ILCS 559/20-20 to 20-25) and all applicable administrative rules. The “estimated total project cost” is a good faith approximation of the costs of an entire project being paid for in whole or in part by appropriated capital funds to construct a public work. The goal of the Illinois Apprenticeship Initiative is that apprentices will perform either 10% of the total labor hours actually worked in each prevailing wage classification or 10% of the estimated labor hours in each prevailing wage classification, whichever is less. Grantees will be permitted to seek from the Department a waiver or reduction of this goal in certain circumstances pursuant to 30 ILCS 559/20-20(b). The grantee must ensure compliance for the life of the entire project, including during the term of the grant and after the term ends, if applicable, and will be required to report on and certify its compliance.

**ARTICLE XXV
ADDITIONAL BUDGET PROVISIONS**

25.1. Restrictions on Discretionary Line-Item Transfers. Unless prohibited from doing so in 2 CFR 200.308 or 44 Ill. Admin. Code 7000.370(b), transfers between approved line items may be made without Grantor’s approval only if the total amount transferred does not exceed the allowable variance of the greater of either (1) ten percent (10%) of the Budget line item, or (2) one thousand dollars (\$1,000) of the Budget line item. Discretionary line-item transfers may not result in an increase to the Budget Total. Transfers above 10% of a line item, or over \$1,000 must be requested in advance and be approved by the Grantor.

**ARTICLE XXVI
ADDITIONAL TERMINATION, SUSPENSION, BILLING SCHEDULE AND NON-COMPLIANCE PROVISIONS**

26.1. Remedies for Non-Compliance. If Grantor suspends or terminates this Agreement pursuant to Article XIII herein, Grantor may also elect any additional remedy allowed by law, including, but not limited to, one or more of the following remedies:

- (a) Direct the Grantee to refund Grant Funds disbursed to it under this Agreement for costs determined ineligible,

(b) Direct the Grantee to remit an amount equivalent to the “Net Salvage Value” of all equipment or materials purchased with Grant Funds provided under this Agreement. For purposes of this Agreement, “Net Salvage Value” is defined as the amount realized, or that the Parties agree is likely to be realized from, the sale of equipment or materials purchased with Grant Funds provided under this Agreement at its current fair market value, less selling expenses; and,

(c) Direct the Grantee to transfer ownership of equipment or materials purchased with Grant Funds provided under this Agreement to the Grantor or its designee.

26.2. Grant Refunds. In accordance with the Illinois Grant Funds Recovery Act, 30 ILCS 705/1 et seq., the Grantee must, within forty-five (45) days of the effective date of a termination of this Agreement, refund to Grantor, any balance of Grant Funds not spent or not obligated as of said date.

**ARTICLE XXVII
ADDITIONAL MODIFICATION PROVISIONS**

27.1. Unilateral Modifications. The Parties agree that Grantor may, in its sole discretion, unilaterally modify this Agreement without prior approval of the Grantee when the modification is initiated by Grantor for the sole purpose of increasing the Grantee’s funding allocation as additional funds become available for the Award during the program year covered by the Term of this Agreement. A unilateral modification may also be used to de-obligate funds without prior approval of the Grantee when, a) a project is completed and funds remain that are no longer needed for the grant project, b) to secure unobligated/unspent funds, c) termination of the Grant Agreement.

27.2. Term Extensions. The Grantee acknowledges that all Grant Funds must be expended or legally obligated, and all Grant Activities, Deliverables, Milestones and Performance Measures (Exhibits A, B and E) must be completed during the Grant Term set forth in paragraph 2.1 herein. Extensions of the Award Term will be granted only for good cause, subject to the Grantor’s discretion. Pursuant to the Grant Funds Recovery Act (30 ILCS 705/1 et seq.), no Award may be extended in total beyond a two (2)-year period unless the Grant Funds are expended or legally obligated during that initial two-year period, or unless Grant Funds are disbursed for reimbursement of costs previously incurred by the Grantee. If Grantee requires an extension of the Award Term, Grantee should submit a written request to the Grant Manager at least sixty (60) days prior to the end of the Award Term or extended Award Term, as applicable, stating the reason for the extension.

**ARTICLE XXVIII
ADDITIONAL EQUIPMENT OR PROPERTY PROVISIONS**

28.1. Equipment Management. The Grantee is responsible for replacing or repairing equipment and materials purchased with Grant Funds that are lost, stolen, damaged, or destroyed. Any loss, damage or theft of equipment and materials shall be investigated and fully documented, and immediately reported to the Grantor and, where appropriate, the appropriate authorities.

28.2. Grantee will be responsible for the maintenance of any equipment purchased with grant funds.

**ARTICLE XXIX
APPLICABLE STATUTES**

To the extent applicable, Grantor and Grantee shall comply with the following:

29.1. Grantee Responsibility. All applicable federal, State and local laws, rules and regulations governing the performance required by Grantee shall apply to this Agreement and will be deemed to be included in this Agreement the same as though written herein in full. Grantee is responsible for ensuring compliance with all applicable laws, rules and regulations, including, but not limited to those specifically referenced herein. Except where expressly required by applicable laws and regulations.

29.2. Land Trust/Beneficial Interest Disclosure Act (765 ILCS 405/2.1). No Grant Funds shall be paid to any trustee of a land trust, or any beneficiary or beneficiaries of a land trust, for any purpose relating to the land, which is the subject of such trust, any interest in such land, improvements to such land or use of such land unless an affidavit is first filed with the Grantor identifying each beneficiary of the land trust by name and address and defining such interest therein.

29.3. Historic Preservation Act (20 ILCS 3420/1 et seq.). The Grantee will not expend Grant Funds under this Agreement which result in the destruction, alteration, renovation, transfer or sale, or utilization of a historic property, structure or structures, or in the introduction of visual, audible or atmospheric elements to a historic property, structure or structures, which will result in the change in the character or use of any historic property, except as approved by the Illinois Department of Natural Resources, Historic Preservation Division. The Grantee shall not expend Grant Funds under this Agreement for any project, activity, or program that can result in changes in the character or use of historic property, if any historic property is located in the area of potential effects without the approval of the Illinois Department of Natural Resources, Historic Preservation Division. 20 ILCS 3420/3(f).

29.4. Steel Products Procurement Act (30 ILCS 565 et seq.). The Grantee, if applicable, hereby certifies that any steel products used or supplied in accordance with this Award for a public works project shall be manufactured or produced in the United States per the requirements of the Steel Products Procurement Act (30 ILCS 565 et seq).

**ARTICLE XXX
ADDITIONAL MISCELLANEOUS PROVISIONS**

30.1. Workers' Compensation Insurance, Social Security, Retirement and Health Insurance Benefits, and Taxes. The Grantee shall provide Workers' Compensation insurance where the same is required and shall accept full responsibility for the payment of unemployment insurance, premiums for Workers' Compensation, Social Security and retirement and health insurance benefits, as well as all income tax deduction and any other taxes or payroll deductions required by law for its employees who are performing services specified by this Agreement.

**ARTICLE XXXI
ADDITIONAL REQUIRED CERTIFICATIONS**

The Grantee makes the following certifications as a condition of this Agreement. These certifications are required by State statute and are in addition to any certifications required by any Federal funding source as set forth in this

Agreement. Grantee's execution of this Agreement shall serve as its attestation that the certifications made herein are true and correct.

31.1. Applicable Taxes. The execution of this Agreement by the Grantee is its certification that (i) it is current as to the filing and payment of any federal, state and/or local taxes applicable to Grantee; and (ii) it is not delinquent in its payment of moneys owed to any federal, state, or local unit of government.

31.2. Lien Waivers. If applicable, the Grantee shall monitor construction to assure that necessary contractor's affidavits and waivers of mechanics liens are obtained prior to release of Grant Funds to contractors and subcontractors.

**ARTICLE XXXII
INCORPORATION**

32.1. Incorporation into Agreement. The full Uniform Application, Uniform Budget, Grant Manual, are hereby incorporated into this Agreement and therefore are a part of this Agreement.

PART THREE –PROJECT-SPECIFIC TERMS

In addition to the uniform requirements in **PART ONE** and Grantor-Specific Terms in **PART TWO**, Grantor has the following additional requirements for this Project:

**ARTICLE XXXIII
REPORT DELIVERABLE SCHEDULE**

33.1. Periodic Reports. The Grantee is required to submit the following periodic reports based on the Reporting Period and Due Dates listed below.

(a) **Periodic Performance Report (PPR)** – describes the progress of the activities/implementation of the project

(b) **Periodic Financial Report (PFR)** – documents expenditure of funds in accordance with the budget line items as detailed in the approved Uniform Budget.

<u>Reporting Period</u>	<u>PPR and PFR Due Date</u>
January 1 – March 31	April 15
April 1 – June 30	July 15
July 1 – September 30	October 15
October 1 – December 31	January 15

33.2. Final Project Report. The Grantee shall submit a written Final Project Report to the Grantor no later than 30 days following the completion of the project or the ending date of the grant agreement, whichever is earlier, in accordance with the applicable administrative rules. The final report shall be in the form or format provided by the Grantor.

Final Project Report shall include but not be limited to the following information:

- Grant agreement number
- Grantee name, address, and telephone number
- Timeframe of the report
- Name and telephone number or e-mail address of Grantee representative completing the report
- Project objective as described in the application and grant agreement
- Completed project description
- Summary of the project accomplishments
- Any other information/documentation as required by the Grantor

33.3. Failure to provide the Final Project Report. As required may render the Grantee ineligible to receive payments under the current award or make them ineligible for future awards.

**ARTICLE XXXIV
EQUIPMENT REPORTS**

34.1. Equipment reports. Are due on December 31st during each of the first 5 years following the project award. The Equipment Use Report shall suffice as the Annual Progress Report required if the equipment purchase was the only aspect of the project. (Administrative Rule 3060.80 (b) 7)

**ARTICLE XXXV
REIMBURSEMENT OF COSTS INCURRED**

35.1. Reimbursement based program. Grant funds are available on a reimbursement basis for expenditures incurred by the Grantee during the grant Term as identified in this Agreement. Costs incurred prior to the effective date identified in the Term of this Agreement, and costs incurred after the expiration date for the Term of this Agreement are not eligible for reimbursement.

**ARTICLE XXXVI
FINANCIAL INFORMATION**

36.1. Project Costs. Project costs eligible for assistance shall be determined upon the basis of criteria set forth for the Boat Access Area Development Programs as so specified in 17 Illinois Administrative Code Part 3035.

36.2. Payment. Any payment(s) to the Grantee will be made as reimbursement for eligible expenses following submission to Grantor of a certified billing request listing all funds expended and including any other documentation required by Grantor following all instructions provided in the Implementation and Billing Packet.

36.3. Project Billings. Project billings are to be submitted to the Grantor quarterly. Forms and instructions presented in the Implementation and Billing Requirements must be used.

26.4. Final Billing. A project shall be deemed completed for grant payment when the Grantee submits a final certified project billing form seeking final grant reimbursement which is approved for payment by the Grantor. Failure by the Grantee to submit required billing forms and substantiating documentation within 60 days following the project expiration date will result in the Grantee forfeiting all project reimbursements and relieves the Grantor from further payment obligations on the grant. Any grant funds remaining after final reimbursement to the Grantee will be reprogrammed at the discretion of Grantor.

36.5. Record Maintenance. The Grantee shall maintain, for a minimum of three years following project completion, satisfactory financial accounts, documents, and records associated with the project and the disbursement of grant funds pursuant to this Agreement, and shall make them available to the Grantor, or the Auditor General, or the Attorney General if requested, for auditing at reasonable times. Failure by the Grantee to maintain such accounts, documents, and records as required herein shall establish a presumption in favor of the State of Illinois for recovery of any funds paid by the State per this Agreement for which adequate records are not available to support their purported disbursement.

26.6. Audit. The Grantee, within 30 days of notification, shall provide the Grantor with a copy of any agency-wide audit(s) covering the period of the grant expenditures that report "findings" involving the herein referenced project.

**ARTICLE XXXVII
PROGRAM SPECIFIC TERMS**

37.1. Project Implementation. Grantee is solely responsible for the design and implementation of the project described in its Project Application, the terms and conditions of which are hereby incorporated by reference and made a part of this Agreement. Failure by the Grantee to comply with any of the Agreement terms or the terms of the Project Application shall be cause for the suspension of all grant assistance obligations

thereunder and may result in debarment for two grant cycles.

37.2. Project Progress. The Grantee agrees to implement and complete the approved project pursuant to the time schedule and plans set forth in the Project Application. Failure to render satisfactory progress or to complete the approved project to the satisfaction of the Grantor per the terms of this Agreement is cause for suspension and/or termination of all obligations of the Grantor under this Agreement.

37.3. Operation and Maintenance. Grantee must comply with and abide by the following operation and maintenance provisions as well as all provisions identified in 17 Ill. Adm. Code 3035.70.

(a) Operation and maintenance of the grant project facility is the responsibility of the Local Agency. The boat launching and access facilities shall be continuously operated and maintained by the Local Agency at no cost to the Grantor and shall be operated and utilized in a manner that maximizes the intended benefits to and for the general public.

(b) All land and water areas that are open to the public shall be available for use and enjoyment by the public without regard to race or color, sex, national origin, age or disability. No lessee or licensee of an area under a concessionaire providing a service to the public, including facilities and accommodations, shall discriminate against any person or persons because of race, color, sex, national origin, age or disability in the conduct of its operation under the lease, license or concession agreement.

(c) No improvements, alterations or modifications of these facilities shall be permitted except with the prior approval in writing by the Grantor. Approval will be given by the Grantor if the improvements, alterations or modifications comply with the criteria in Section 3035.50.

(d) The Grantor shall have access to all facilities at all times to ensure management and use of the facilities are in compliance with specified program regulations.

(e) Boats with gasoline or diesel motors shall not be prohibited from using any facility funded through State Boating Act Funds to launch and recover unless the facility is a designated canoe launch facility as approved by the Grantor.

37.4. Develop Projects. Projects receiving development/construction grant assistance only, shall be bound by the terms of this Agreement for the period of time specified below relating to the total amount of grant funds received. (17 Ill. Adm. Code 3025.70)

<u>Total Grant Award</u>	<u>Time Period After Final Billing</u>
\$1 to \$25,000	7 years
\$25,001 to \$100,000	12 years
\$100,000 to \$200,000	17 years

37.5. Acquisition Projects. Land acquired with funding assistance from the BAAD program shall be operated and maintained in perpetuity for public outdoor recreation use.

37.6. Permits/Licenses. In connection with project construction, and the subsequent operation and maintenance of the facilities, the Grantee agrees that it shall be responsible for and obtain all permits, licenses, or forms of consent required to complete the project. Failure to obtain any required permit or approval may jeopardize grant reimbursement and/or cause debarment.

37.7. Environmental and Cultural Resource Compliance. Approved grant project construction shall not

commence and no payment shall be made under this grant until the Grantee, as set forth under the Grantor's Comprehensive Environmental Review Process (CERP), has initiated and completed all necessary project review and consultation with the Grantor as required by section 11 of the Endangered Species Protection Act, 520 ILCS 10/11; section 17 of the Illinois Natural Areas Preservation Act, 525 ILCS 30/17; the mitigation or compensation determinations required by the Interagency Wetland Policy Act, 20 ILCS 830/1 et seq.; and the environmental and economic impact determination required by the Historic Preservation Act, 20 ILCS 3420/4.

37.8. Use of Illinois Resident Labor. At least 50% of the total labor hours on the project must be performed by actual residents of the State of Illinois. (20 ILCS 805/805-350).

37.9. Public Access. Any property acquired or developed through assistance from the Illinois BAAD grant program must be open to the public for outdoor recreation use without regard to race or color, creed, national origin, sex or disability, nor based on residence, except to the extent that reasonable differences in user fees may be imposed amounting to no more than double the fees charged to residents.

37.10. Conversion. Property acquired or developed with BAAD funds may not be converted to a use other than public outdoor recreation use as provided in this Part without prior Grantor approval. Approval for property conversion will be granted only if the Grantee substitutes replacement property of at least equal market value and comparable outdoor recreation usefulness, quality and location. (17 Ill. Adm. Code 3025.70)

37.11. Conversion Breach. Any deviation or conversion of the project site(s) from public BAAD recreation use without Grantor approval shall be considered a breach of this Agreement resulting in the Grantee being held liable for replacing said converted property with comparable land as deemed acceptable by the Grantor.

37.12. Property Appraisal. Projects receiving acquisition assistance must have an appraisal provided by the Grantee and submitted to the Grantor for review and certification to establish the property's market value. The appraisal must be completed to Grantor specifications. (17 Ill. Adm. Code 3035.70)

37.13. Title/Deed. For projects receiving development assistance, the Grantee must possess either fee simple title or other means of legal control and tenure (easement, lease, etc.) over the property being improved for a period of time commensurate with the program amortization schedule shown in the administrative rules, unless otherwise approved by the Grantor. The Grantor will consider, on a case-by-case basis, lease arrangements for shorter periods when State statute prohibits a unit of local government from entering into such a long-term agreement, or other circumstances beyond the control of the local unit of government prohibit such arrangements. The Grantee must also adhere to applicable local bidding and procurement requirements. (17 Ill. Adm. Code 3035.70)

37.14. Assignment. No assignment of grant provisions or duties is allowed.

37.15. Americans with Disabilities Act. All facilities constructed with state BAAD grant assistance must be designed and developed to fully accommodate accessibility standards as per the Illinois Accessibility Code Standards, the Americans with Disabilities Act (ADA) (42 U.S.C. 12101 et seq.), and the regulations thereunder 28 CFR 35.130.

37.16. Project Site Access. It is agreed and understood by the Grantee that a Grantor representative shall have access to the project site to make periodic inspections as work progresses. It is further agreed and understood by the Grantee that Grantor reserves the right to inspect the completed project prior to project acceptance and grant reimbursement to the Grantee.

37.17. Project Acknowledgement. The Grantee shall give proper credit to the appropriate Fund and coordinate with the Grantor on any publication, written document, news article, television and radio release, interview or personal presentation, if initiated by the Grantee, which refers to the project.

37.18. Signage. The Grantee shall post a sign, include a logo or affix a decal, if practical and applicable, crediting the applicable Fund. Signs, logos, and decals shall be supplied by the Grantor. The IDNR will provide guidance to the Grantee for posting of signs, logos and decals on projects awarded under this Fund.

37.19. Incorporation. The OSLAD Grant Manual, the Grant Application, Grant Budget, and Implementation and Billing Packet is hereby incorporated herein by reference and made a material and binding part of this Agreement.



City of Wilmington Public Works

To: Honorable Mayor Dietz and City Council Members
From: James Gretencord, Director of Public Works
Subject: January Director's Report
Date: February 13, 2024

Flooding Incident January 26, 2024:

- Public Works Staff worked around the clock from 1/26 to 1/29 helping emergency personnel secure flooding sites with barricades, to assure water tower levels would be maintained after flood levels at our pump house reached over two feet and to keep other critical infrastructure operational.
- From January 26th to February 3rd Public Works Employees averaged 23.35 hours of overtime.

In addition to this I would like to thank the following entities/companies for their help and quick response to Wilmington Public Works while facing this flooding event:

- Chamlin and Associates
- Clennon Electric
- City of Morris Public Works
- Xylem Dewatering Solutions
- Inman Electric Motors
- On Site Repair Services, INC.

City Crew:

- Completed 38+ Work Orders
- Plowed/Salted 8 Snow/Ice Events
- Repaired 3 Water Main Breaks
- Removed Christmas wreaths and banners

Sewer:

- Completed Annual Federal Sludge Report
- Completed Semi-Annual IEPA Sludge Report
- Completed SCADA upgrades to Riverwood Liftstation
- Completed 21 utility locates

Water:

- Collected 45 samples and submitted to the state
 - IEPA- Monthly Operating Report - added mandatory changes and updates to daily operations for compliance.
 - Completed Annual IEPA Lime Sludge Report
 - Sanitary Survey Response submitted to IEPA
 - Completed 14 service orders
 - Completed 4 work orders for on/off
 - 11-meter change-outs
-



MEMO

Date: February 13, 2024

To: Honorable Mayor Dietz and City Council Members

From: James Gretencord, Director of Public Works

Cc: Jeannine Smith, City Administrator
Nancy Gross, Finance Director

Re: State of Emergency Invoices

Budget Impact: \$24,521.35 ESDA Line Item 07-00-7500

Request: Approve the invoices relating to the State of Emergency.

Discussion: The following items are invoices received due to the flooding of our WTP pump house. In addition to these items, also included are estimates that will be voted on and paid at a later date once final inspections have been completed and final invoices are received.

Invoices Received To Date: 2/7/2024		
Company	Cost	Reason
Inman Electric Motors	\$ 11,363.10	Three new Motors 2-50HP 1-30HP
On Site Repair Services	\$ 11,737.22	Three new motor installs and one motor realignment
Grainger	\$ 922.18	4 clearwell transducers + coupling grease
Whitmore Ace	\$ 257.25	Misc. Needed items: visqueen, drain pain etc..
Dunkin Donuts	\$ 59.78	Coffee for First Responders 1/26/2024
Wilmington Pizzeria	\$ 182.00	Lunch for all P.W. Employees and Contractors 1/27/2024
<i>Total:</i>	\$ 24,521.53	
Future Invoice Estimates:(To be voted on later)		
Company	Estimated Cost	Reason
Clennon Electric	\$ 38,000.00	Inspection and repair of electrical systems that were submerged in water, diesel generator rental, 2 new transformers, 480V breaker install, misc electrical parts
Xylem	\$ 18,500.00	Rental 2 diesel powered trash pumps for WTP by-pass pumping
Heritage FS	\$ 3,150.00	Fuel for diesel generator
Servpro	\$ 1,500.00	Dehumidifier rental for pump house
Park Restorations	N/A	Waiting for insurance adjusters, building inspector report
Well 3 Restoration	N/A	Staff has not gained access to the site yet

Motion: Approve the Invoices relating to the State of Emergency at a total of \$24,521.35

Thank you in advance for your consideration of this request.



Inman Electric Motors

314 Civic Road · PO Box 1108 · La Salle, IL 61301
P: 815-223-2288 · F: 815-223-7108
www.inmanelectric.com

Invoice

Customer Number

CITWIL

Invoice Number

SSI13984

Contact

James

Order Date

1/27/2024

Shipped Date

1/27/2024

Invoice Date

1/31/2024

Bill To:

City of Wilmington
1165 S Water
WILMINGTON, IL 60481

Ship To:

City of Wilmington
1165 S Water
WILMINGTON, IL 60481

Ship Via

Our Truck

Terms

Net 30

Salesperson

House Employee

FOB

Customer PO

Verbal/Gretencord

Original Order #

S14337

Product ID	Qty	Ship	Description	Sales Price	Total
Returned					
	1	1	Toshiba 60 1800 326T 3 TEFC 840GLO 460V Mill & Chem, F1 Assembly	5,418.44	5,418.44
	1	1	Toshiba 50 1800 326T 3 TEFC 840GLO Mill & Chem, 460V, F1 Assembly	3,593.01	3,593.01
	1	1	Toshiba 30 1200 326T 3 TEFC 840GLO 460V	3,906.28	3,906.28

New motors sent JM22065, NM2593 & NM2459
Emergency Delivery

Subtotal: 12,948.73

Freight: 235.80

Other: 0.00

0.0000 % Sales Tax 1: 0.00

0.0000 % Sales Tax 2: 0.00

Total: 13,184.53

Thank you!

Our Tax ID: 36-2416376

Your Tax ID:

New Total 7735.09



Inman Electric Motors

314 Civic Road · PO Box 1108 · La Salle, IL 61301
P: 815-223-2288 · F: 815-223-7108
www.inmanelectric.com

Invoice

Customer Number

CITWIL

Invoice Number

SSI14009

Contact

James Gretencord

Order Date

2/1/2024

Shipped Date

2/1/2024

Invoice Date

2/2/2024

Bill To:

City of Wilmington
1165 S Water
WILMINGTON, IL 60481

Ship To:

City of Wilmington
1165 S Water
WILMINGTON, IL 60481

Ship Via

Your Truck

Terms

Net 30

Salesperson

House Employee

FOB

Customer PO

Verbal/James

Original Order #

S14364

Product ID	Qty	Ship	Description	Sales Price	Total
	1	1	Toshiba 50 1800 326T 3 TEFC 840GLO Mill & Chem, 460V, F1 Assembly	3,593.01	3,593.01

New motor sent, NM2859
Frt= S&H

Subtotal: 3,593.01

Freight: 35.00

Other: 0.00

0.0000 % Sales Tax 1: 0.00

0.0000 % Sales Tax 2: 0.00

Total: 3,628.01

Thank you!

Our Tax ID: 36-2416376

Your Tax ID:

On Site Repair Services, Inc.

PO Box 1486

La Salle, IL 61301

815-223-4058



INVOICE

BILL TO

City of Wilmington Water

Treatment

1165 S Water Street

Wilmington, IL 60418

INVOICE # 17469

DATE 01/29/2024

DUE DATE 02/28/2024

TERMS Net due in 30 days

DESCRIPTION

AMOUNT

OSR-111292 1/27/2024

8,218.96

Furnish labor, material and equipment to change out pump motor on P-15 & P-17; align and test run per instructions.

BALANCE DUE

\$8,218.96

We accept VISA, MasterCard & American Express.
A fee of 3.75% will be added to all credit card payments.

On Site Repair Services, Inc.

PO Box 1486

La Salle, IL 61301

815-223-4058



INVOICE

BILL TO

CITY OF WILMINGTON

WATER TREATMENT PLANT

1165 S Water Street

Wilmington, IL 60481

INVOICE # 17478

DATE 02/06/2024

DUE DATE 03/07/2024

TERMS Net due in 30 days

DESCRIPTION

AMOUNT

OSR-111370 2/5/2024

3,518.26

Furnish labor, material and equipment to change out & align 50HP Motor; align 60 HP Motor per instructions.

BALANCE DUE

\$3,518.26

We accept VISA, MasterCard & American Express.
A fee of 3.75% will be added to all credit card payments.



6001 W. 115TH ST.
ALSIP, IL 60803-5152
www.grainger.com

INVOICE

GRAINGER ACCOUNT NUMBER 836300012
INVOICE NUMBER 9008564297
INVOICE DATE 02/05/2024
DUE DATE 03/06/2024
AMOUNT DUE \$511.84

SHIP TO

CITY OF WILMINGTON
1165 S WATER ST
WILMINGTON IL 60481-1633

PO NUMBER: JAMES GRETECORD
CALLER: JAMES GRETECORD
CUSTOMER PHONE: 7798012127
ORDER NUMBER: 1505472947
INCO TERMS: FOB DESTINATION

BILL TO
CITY OF WILMINGTON
1165 S WATER ST
WILMINGTON IL 60481-1633

Pay invoices online at:
www.grainger.com/invoicing
Sign up for paperless invoicing at:
www.grainger.com/paperlessinvoicing

THANK YOU! FEI NUMBER 36-1150280
FOR QUESTIONS ABOUT THIS INVOICE OR ACCOUNT CALL **1-800-472-4643**

PO LINE #	ITEM #	DESCRIPTION	QUANTITY	UNIT PRICE	TOTAL
	41NR74	GREASE, 14 OZ, CARTRIDGE, WHITE, NSF H2 MANUFACTURER # 50350	5	20.30	101.50
	2HLV5	PRESSURE TRANSMITTER, 0 TO 15 PSI, 1/4 IN MANUFACTURER # 628-07-GH-P1-E1-S1	2	205.17	410.34
Delivery #: 6619954137 Date: 02/05/2024 Carrier: ZDC WILL CALL No: of Pkgs: 1 Wt: 5.700 PICKED UP FROM: DC MINOOKA 005 701 GRAINGER WAY, MINOOKA, IL 60447-9998					

*THIS PURCHASE IS GOVERNED EXCLUSIVELY BY GRAINGER'S TERMS OF SALE, INCLUDING: (I) DISPUTE RESOLUTION REMEDIES, AND (II) CERTAIN WARRANTY AND DAMAGES LIMITATIONS AND DISCLAIMERS IN EFFECT AT THE TIME OF THE ORDER, WHICH ARE INCORPORATED BY REFERENCE HEREIN. GRAINGER'S TERMS OF SALE ARE AVAILABLE AT WWW.GRAINGER.COM
PRODUCT RETURN INSTRUCTIONS ARE AVAILABLE AT WWW.GRAINGER.COM/RETURNS*

INVOICE SUB TOTAL 511.84

These items are sold for domestic consumption. If exported, purchaser assumes full responsibility for compliance with US export controls. Diversion contrary to US law prohibited.

Reprint

PAY THIS INVOICE - PAYMENT TERMS Net 30 days after inv IN U.S. DOLLARS.

AMOUNT DUE \$511.84

PLEASE DETACH THIS PORTION AND RETURN WITH YOUR PAYMENT

BILL TO:

CITY OF WILMINGTON
1165 S WATER ST
WILMINGTON IL 60481-1633
UNITED STATES OF AMERICA

REMIT TO:

GRAINGER
DEPT. 836300012
PALATINE, IL 60038-0001

836300012900856429710000511841000000010000000100000024030636

X	ACCOUNT NUMBER	DATE	INVOICE NUMBER	AMOUNT DUE
	836300012	02/05/2024	9008564297	\$511.84



6001 W. 115TH ST.
ALSIP, IL 60803-5152
www.grainger.com

INVOICE

GRAINGER ACCOUNT NUMBER 836300012
INVOICE NUMBER 9007009229
INVOICE DATE 02/02/2024
DUE DATE 03/03/2024
AMOUNT DUE \$410.34

SHIP TO
ATTN: JAMES GRETECORD
CITY OF WILMINGTON
CRAIG PALMER
1165 S WATER ST
WILMINGTON IL 60481-1633

PO NUMBER: JAMES GRETECORD
CALLER: JAMES GRETECORD
CUSTOMER PHONE: 7798012127
ORDER NUMBER: 1505350994
INCO TERMS: FOB DESTINATION

BILL TO
CITY OF WILMINGTON
1165 S WATER ST
WILMINGTON IL 60481-1633

Pay invoices online at:
www.grainger.com/invoicing
Sign up for paperless invoicing at:
www.grainger.com/paperlessinvoicing

THANK YOU! FEI NUMBER 36-1150280
FOR QUESTIONS ABOUT THIS INVOICE OR ACCOUNT CALL **1-800-472-4643**

PO LINE #	ITEM #	DESCRIPTION	QUANTITY	UNIT PRICE	TOTAL
	2HLV5	PRESSURE TRANSMITTER,0 TO 15 PSI,1/4 IN MANUFACTURER # 628-07-GH-P1-E1-S1 Delivery #:6619752435 Date: 02/02/2024 Carrier: ZDC WILL CALL No:of Pkgs:1 Wt: 0.800 PICKED UP FROM: DC MINOOKA 005 701 GRAINGER WAY,MINOOKA,IL 60447-9998	2	205.17	410.34

*THIS PURCHASE IS GOVERNED EXCLUSIVELY BY GRAINGER'S TERMS OF SALE, INCLUDING: (I) DISPUTE RESOLUTION REMEDIES, AND (II) CERTAIN WARRANTY AND DAMAGES LIMITATIONS AND DISCLAIMERS IN EFFECT AT THE TIME OF THE ORDER, WHICH ARE INCORPORATED BY REFERENCE HEREIN. GRAINGER'S TERMS OF SALE ARE AVAILABLE AT WWW.GRAINGER.COM
PRODUCT RETURN INSTRUCTIONS ARE AVAILABLE AT WWW.GRAINGER.COM/RETURNS*

INVOICE SUB TOTAL 410.34

These items are sold for domestic consumption. If exported, purchaser assumes full responsibility for compliance with US export controls. Diversion contrary to US law prohibited.

Reprint

PAY THIS INVOICE - PAYMENT TERMS Net 30 days after inv IN U.S. DOLLARS.

AMOUNT DUE \$410.34

PLEASE DETACH THIS PORTION AND RETURN WITH YOUR PAYMENT

BILL TO:

CITY OF WILMINGTON
1165 S WATER ST
WILMINGTON IL 60481-1633
UNITED STATES OF AMERICA

REMIT TO:

GRAINGER
DEPT. 836300012
PALATINE, IL 60038-0001

836300012900700922910000410341000000010000000100000024030387

X ACCOUNT NUMBER 836300012 DATE 02/02/2024 INVOICE NUMBER 9007009229 AMOUNT DUE \$410.34

THANK YOU FOR SHOPPING AT
WHITMORE ACE HARDWARE - 3600I
1105 S. WATER ST
WILMINGTON, IL 60481
WWW.WHITMOREACE.COM
(815) 476-7731

THANK YOU FOR SHOPPING AT
WHITMORE ACE HARDWARE - 3600I
1105 S. WATER ST
WILMINGTON, IL 60481
WWW.WHITMOREACE.COM
(815) 476-7731

SERVING OUR CUSTOMERS SINCE 1896
TO OUR CUSTOMERS AND FRIENDS

SERVING OUR CUSTOMERS SINCE 1896
TO OUR CUSTOMERS AND FRIENDS

1/28/24 9:51AM KS 553 SALE

99706 1 EA 19.59 EA N
GARDNER HOSE LD 5/8"X15 19.59

IB-TOTAL:\$ 19.59 TAX: \$.00
TOTAL: \$ 19.59

LARGE AMT: 19.59



>> JRNL# G32486 INV#327553
CUST NO: 16840/ 2
ACE REWARDS ID # 19818729162

Customer Copy

02/01/24 8:56AM JW1 553 SALE

45453 1 10 64.99 10 N
PIPE S&D LEAD LATRL6X10 64.99

SUB-TOTAL:\$ 64.99 TAX: \$.00
TOTAL: \$ 64.99

CHARGE AMT: 64.99



==>> JRNL# G34111 INV#327640
CUST NO: 16840/ 4
ACE REWARDS ID # 19818729162

Customer Copy

Name: X
RETENCORD, JAMES
Address: WATER
Phone #: JAMES

See our return policy at:
<https://www.whitmoreace.com/policies>

Tell us about your experience
today and Enter to win a \$50
gift card!

To participate
Visit: TalkTo.AceHardware.com
text HELPFUL to 223439

This survey invitation is

Name: X
KOLINSKI, BRIAN
Acct: CITY WORKERS (PUBLIC WORKS)
PO#: BRIAN

See our return policy at:
<https://www.whitmoreace.com/policies>

Tell us about your experience
today and Enter to win a \$50
gift card!

To participate
* Visit: TalkTo.AceHardware.com
or text HELPFUL to 223439

* This survey invitation is
valid for 72 hours

* Store # 03600
* Survey approximately 5 mins

No purchase necessary.
Must be 18 or older to
enter sweepstakes. Void
where prohibited. See rules
at: TalkTo.AceHardware.com

THANK YOU FOR SHOPPING AT
 WHITMORE ACE HARDWARE - 3600I
 1105 S. WATER ST
 WILMINGTON, IL 60481
 WWW.WHITMOREACE.COM
 (815) 476-7731

SERVING OUR CUSTOMERS SINCE 1896
 TO OUR CUSTOMERS AND FRIENDS

01/29/24 8:48AM KS 553 SALE

 1005957 1 OZ 6.99 OZ N
 CLOROX BLEACH REG 43OZ 6.99
 7810161 1 EA 7.99 EA N
 CHEM RESIST SPRAYER 32OZ 7.99
 SUB-TOTAL:\$ 14.98 TAX: \$.00
 TOTAL: \$ 14.98
 CHARGE AMT: 14.98



====> JRNL# G32694 INV#327560
 CUST NO: 16840/ 2
 ACE REWARDS ID # 19818729162

Customer Copy

M

Name : X
 GRETENCORD, JAMES
 Acct: WATER
 PO#: JAMES

See our return policy at:
<https://www.whitmoreace.com/policies>

 Tell us about your experience
 today and Enter to win \$500

THANK YOU FOR SHOPPING AT
 WHITMORE ACE HARDWARE - 3600I
 1105 S. WATER ST
 WILMINGTON, IL 60481
 WWW.WHITMOREACE.COM
 (815) 476-7731

SERVING OUR CUSTOMERS SINCE 1896
 TO OUR CUSTOMERS AND FRIENDS

02/01/24 8:18AM JW1 553 SALE

 GD0794MBLKBLV 1 EA 18.99 EA N
 HIGH DEXTERITY OPEN CUFF GLOV 18.99
 7561913 1 EA 7.99 EA N
 ACE WINTR GLOVE LATX XL 7.99
 7803018 1 EA 11.99 EA N
 CHEM GLOVE ORG PVC LG 11.99
 SUB-TOTAL:\$ 38.97 TAX: \$.00
 TOTAL: \$ 38.97
 CHARGE AMT: 38.97



====> JRNL# G34105 INV#327639
 CUST NO: 16840/ 4
 ACE REWARDS ID # 19818729162

Customer Copy

B R

Name : X
 KOLINSKI, BRIAN
 Acct: CITY WORKERS (PUBLIC WORKS)
 PO#: BRIAN

See our return policy at:

THANK YOU FOR SHOPPING AT
 WHITMORE ACE HARDWARE - 3600I
 1105 S. WATER ST
 WILMINGTON, IL 60481
 WWW.WHITMOREACE.COM
 (815) 476-7731

SERVING OUR CUSTOMERS SINCE 1896
 TO OUR CUSTOMERS AND FRIENDS

WILMINGTON PIZZERIA
 205 E BALTIMORE ST
 WILMINGTON, IL 60481

Ref #: 0002

Server ID: 1

Phone Order

XXXXXXXXXXXX5903

VISA Entry Method: Manual

Amount: \$ 167.00

Tip: 15.-

Total: 182.-

01/28/24 9:48AM KS 553 SALE

54301	1	EA	19.59	EA	N
FILM POLY CLR4MIL 10X25					19.59
4894770	1	EA	26.99	EA	N
WTR HTR PAN ALUM 24"					26.99
47800	1	EA	5.99	EA	N
RED COUPLNG GLV 1X3/4"					5.99
71934	1	EA	8.99	EA	N
COUPL BRS3/4MH-3/4MH ACE					8.99
71935	1	EA	8.99	EA	N
HOSE COUPLR BRS 3/4"					8.99
1595685	1	EA	8.99	EA	N
SILICONE II CLEAR 2.80Z					8.99
4595559	2	EA	19.59	EA	N
GORILLA TAPE TOUGH&WIDE					39.18

SUB-TOTAL: \$ 118.72 TAX: \$.00
 TOTAL: \$ 118.72
 CHARGE AMT: 118.72



==>> JRNL# G32485 INV#327552
 CUST NO: 16840/ 2
 ACE REWARDS ID # 19818729162

Customer Copy

01/27/24 13:01:06
 Inv #: 000002 Appr Code: 061639
 Transaction ID: 464027684667919
 Apprvd: Online Batch#: 000543
 AVS Code: ZIP MATCH Z
 CVV2 Code: MATCH M

Customer Copy

Name : X
 GRETENCORD, JAMES
 Acct: WATER
 PO#: JAMES

See our return policy at:
<https://www.whitmoreace.com/policies>

 Tell us about your experience
 today and Enter to win a \$50
 gift card!

Flood 07-00-7500

Dunkin' - Baskin-Robbins'
Store #: 351650
9500 179th St
Tinley Park, IL 60487
(708) 429-9600

534092 RAHIM

CHK 3752
1/26/2024 6:58 AM

Eat In

2 12 Donuts 29.98
1 Box Hot Orig Cof 24.49
Visa \$59.78

*****1191

Tran Type : Purchase
Entry Mode : INSERTED
Auth Code : 015397
VISA CREDIT

AID: A0000000031010

No Signature Required

I agree to pay the above total
amount according to the card
issuer

(merchant agreement if credit
voucher)

Subtotal \$54.47
State Tax \$5.31
Payment \$59.78

Change Due \$0.00

----- Check Closed -----
1/26/2024 6:58 AM

Donut forget to tell us about
today's visit! Talk to us at
www.DunkinBaskinRunsOnYou.com
within 3 days and receive a
FREE CLASSIC DONUT
on your next visit when you
purchase a Medium or Larger Beverage
See restrictions on dunkindonuts.com

Survey Code: 75201-51650-0601-2645

Additional Discounts Will Not Be
Applied to Promotional Offers

Thank You. Come Back Again.

3752
Total Items: 3

Resolution No. 2024-02

RESOLUTION TO DISPOSE OF SURPLUS PROPERTY

WHEREAS, 65 ILCS 5/11-76-4 provides for the methodology to dispose of certain municipal property which is no longer necessary or useful to the city; and

WHEREAS, the City Council of the City of Wilmington has determined that the City of Wilmington no longer needs the items of personal property on the attached Exhibit A, and such items are surplus property.

THEREFORE, BE IT RESOLVED, that the City Council declares that the items on the attached Exhibit to be surplus property; and

BE IT FURTHER RESOLVED that if the cost of disposal, sale, and transportation of the items is more than they are worth, then the items are declared worthless and may be junked or demolished.

BE IT FURTHER RESOLVED that the surplus property may be transferred to another governmental agency or unit pursuant to Illinois statutes.

NOW THEREFORE BE IT RESOLVED that the Public Works Director is hereby authorized to dispose of property identified in Exhibit A in a manner consistent with Illinois law as set forth above.

ADOPTED this ____ day of _____ 2024 with ____ members voting aye, 0 members voting nay, the Mayor voting N/A, with 0 members abstaining or passing and said vote being:

Ryan Jeffries	_____	Kevin Kirwin	_____
Ryan Knight	_____	Dennis Vice	_____
Jonathan Mietzner	_____	Leslie Allred	_____
Thomas Smith	_____	Todd Holmes	_____

Approved this ____ day of _____ 2024

Ben Dietz, Mayor

Attest:

Joie Ziller, Deputy City Clerk

Exhibit A

**Surplus Sheet
City of Wilmington**

Date: 02/13/2024
Name: City of Wilmington
Address: 1165 S. Water Street
Wilmington, IL 60481

Description	Unit Value	Value
2008 Nissan Street Sweeper (VIN JNAPC81L48AE70119)	N/A	N/A



**Environmental Design
International inc.**

Chicago & Joliet

33 W. Monroe St., Suite 1825
Chicago, IL 60603-5326

phone: 312-345-1400
fax: 312-345-0529
web: www.envdesigni.com

3230 Executive Drive
Joliet, IL 60431-8401

phone: 815-730-3444
fax: 815-730-6703

February 5, 2024

Ms. Jeannine Smith, Administrator
City of Wilmington
1165 W. Water Street
Wilmington, IL 60481

Re: Invoices for Kankakee Street Bridge
IDOT Number 11-00044-00-BR
EDI Job Number 8012.001 (10716-1)

Dear Ms. Smith,

Environmental Design International inc. submits two invoices for the referenced project for review and approval by the City.

Invoice #: 10716-1-01
Amount: \$25,562.57
Local Participation @ 20%: \$ 5,112.51
Federal Participation @80%: \$20,450.06
Paid to: Hamilton Consulting Engineers, Inc.*
Invoice Period: 01/19/2023 – 05/31/23
Work Performed: Bridge inspection by Wiss, Janney, Elstner and preparation/follow up.

Invoice #: 1 (EDI 23606)
Amount: \$16,388.38
Local Participation@20%: \$ 3,277.68
Federal Participation@80%: \$13,110.70
Paid to: Environmental Design International inc.*
Invoice Period: 06/01/2023 – 12/31/2023
Work Performed: Preliminary report from Wiss, Janney, Elstner re: bridge status and possible next steps. Review and discuss, contact Pennsylvania limestone bridge expert for guidance, follow up with City.

*Note that the most recent approved Project Program Information form (PPI) revision 4 is included that shows the change of Consultant Company Name from Hamilton Consulting Engineers, Inc. (HCE) to Environmental Design International inc. (EDI) effective June 1, 2023, due to acquisition of HCE by EDI.

The first invoice is therefore from HCE for work performed through 5/31/2023 while the second invoice is from EDI for work performed after the acquisition on 6/1/23.

Upon approval, the City pays the invoices in full through the standard City process, then applies for reimbursement of the Federal Portion as listed from IDOT.



Project status as of 1/1/2024:

IDOT # 11-00044-00-BR	Maximum Allowable Budget	Invoiced through 5/31/2024 (HCE)	Invoiced through 12/31/2024 (EDI)	Remaining to Invoice
Preliminary Engineering	\$ 237,656.00	\$ 109,701.64	\$ 126,090.02	\$ 111,565.98
Federal Participation - 80%	\$ 190,124.80			
Local Participation - 20%	\$ 47,531.20			

Please do not hesitate to contact me with any questions. Thank you for the opportunity to work with the City on this important project.

Respectfully,

Environmental Design International inc.

Kristen R. Hamilton
Manager – EDI Joliet



Project Program Information

Revision Number 4

Federally Funded Yes No Amendment/Supplement: # _____ for _____ FY _____ Cost Increase: _____

Local Agency / Project Information

Detailed Project Description

Bridge Rehabilitation and Widening

County: Kane Cook McHenry
 Lake DuPage Will Various Regional Council Will Council of Mayors transportation@wcgl.org

Local Agency CITY OF WILMINGTON Federal Congressional District(s) 16 Illinois Representative District(s) H 75/S 38 GATA Registration 678604 Local Agency TIN 363006159 DUNS 03-409-1496

MFT Section Number 11-00044-00-BR SAM Cage Code 3VDC4 UEI (Unique Entity Identifier) FJNLGB8J3EE5 Design Approval Date _____ Target Letting Date 03/08/24 State Let
 Local Let

Construction Contract No. _____ Estimate of Const. Cost \$1,100,000.00 Non-Participating Cost _____ Non-Participating Items _____

Contact / General Information

IDOT MFT Engineer Alex.Househ@illinois.gov Subregional Council Will County, (815)254-7700 Bridge Project PM Jeffrey T. Snape, PE LEED AP

Bridge PM Email jsnape@envdesigni.com Program Administrator Hugh O'Hara, Will Co. Governmental League Administrator Email transportation@wcgl.org

Local Agency Official Jeannine Smith Title City Administrator Local Agency Phone (815) 467-2175 Local Agency Email jsmith@wilmington-il.com

Local Agency Address 1165 S. Water Street City Wilmington State IL Zip Code 60481

Local Agency Project Contact Jeffrey T. Snape, PE Consultant Company Name Environmental Design Internati Phase PE Ph 2 IDOT Design Engineer Carmen Ramos Consultant Company TIN 363759119 Consultant Contact Person Jeffrey T. Snape, PE

Consultant Contact Email jsnape@envdesigni.com Consultant Contact Phone (815) 730-3444

TIP ID Number 12-11-0034 ITEP Number _____ HPP Bill Number _____ SRTS Number _____

Funding Type

Fund	Percent	Fund	Percent
Surf Trans Pgm Bridge-(STP-BR Off)	80/20		

Project Location(s)

Key Route Designation	Functional Classification	Street Name		List termini west or north limit, followed by the east or south limit. Provide GIS Station in decimal miles <u>Getting Around Illinois</u>			
		Project Length (miles)	0.14	from/at	Station 0.00	to	Station 0.00
5 0321	5-Major Collector	Kankakee Street		Stewart St	1.04	Chicago St	1.18

Programming of Projects for Add Lanes and Resurfacing Improvement Types

Improvement Type	Length (miles)	Street Name	from/at	Station 0.0	to	Station 0.00
Resurfacing	0.14	Kankakee Stret	Stewart St	1.04	Chicago St	1.18

Transportation Asset Management Plan (TAMP) Information - Bridge Information

Bridge Improvement Type	Facility Crossed		Maintenance Type for Bridge Improvement			Proposed Structure #
Facility Carried	Station 0.00	BCC	Existing Structure #			
Kankakee Street - 0321	Forked Creek - waterway	1.09	3	099-7100	n/a	

Add Row

Work Type Classification Codes

Program Classification Codes (PCL)	J06 - Bridge / Twp Br	Maintenance Type PCL J18 & J23	N/A
Fund Type Code(s)	Improvement Type(s)	Fund Type Code(s)	Improvement Type(s)
Roadway (RD)	Bridge Rehab		

Add Row

Project Funding Table

State Job Number	Federal Project Number	Federal Fiscal Year	State Fiscal Year	Est. Total Cost	Federal Participation	Local Participation	State Participation *
<input checked="" type="checkbox"/> P 91 495-11	BRM-9003(807)	2021	2021	\$237,655.00	\$190,124.00	\$47,531.00	
<input checked="" type="checkbox"/> D 91 495-11	7KBL(147)	2023	2023	\$143,062.00	\$114,450.00	\$28,612.00	
<input type="checkbox"/> R							
<input checked="" type="checkbox"/> C 91 495-11	Z3EW(387)	2024	2024	\$1,100,000.00	\$880,000.00	\$220,000.00	
	Construction Engineering	2024	2024	\$60,000.00	\$48,000.00	\$12,000.00	

Multi-Phase Agreement Yes No

Type Bi-Phase Tri-Phase

Maintenance / Jurisdiction Information

Construction only - Check box for all that apply

Work on IDOT Right of Way Yes No

If "Yes" select Type of work on IDOT or other LPA ROW

Emergency Vehicle Preemption (EVP)

- | | | | |
|---|---|--|--|
| <input type="checkbox"/> Traffic Signal | <input type="checkbox"/> New | <input type="checkbox"/> modification | <input type="checkbox"/> combination poles |
| <input type="checkbox"/> Street Lights | <input type="checkbox"/> New | <input type="checkbox"/> modification | <input type="checkbox"/> ornamental |
| <input checked="" type="checkbox"/> Sidewalks | <input type="checkbox"/> New | <input checked="" type="checkbox"/> modification | <input type="checkbox"/> decorative |
| <input checked="" type="checkbox"/> Bike Path | <input checked="" type="checkbox"/> New | <input type="checkbox"/> modification | <input type="checkbox"/> decorative |
| <input type="checkbox"/> Retaining Wall | <input type="checkbox"/> New | <input type="checkbox"/> modification | <input type="checkbox"/> decorative |
| <input type="checkbox"/> Other | <input type="checkbox"/> New | <input type="checkbox"/> modification | |

Railroad Agreement Yes No Intergovernmental Agreement Yes No

Division of Cost

Fund Type	Phase	Federal Participation \$	LPA required match \$	LPA only \$	State Participation \$
- Surf Trans Pgm Bridge (STP-BR Off)	PE Ph1	\$190,124.00	\$47,531.00		
- Surf Trans Pgm Bridge (STP-BR Off)	PE Ph2	\$114,450.00	\$28,612.00		
- Surf Trans Pgm Bridge (STP-BR Off)	CE	\$48,000.00	\$12,000.00		
- Surf Trans Pgm Bridge (STP-BR Off)	CON	\$880,000.00	\$220,000.00		

Add Row

Date Submitted Date Revised Date Completed

Comments

This revised form is submitted to change the Consultant Company Name, FEIN and contact email address from Hamilton Consulting Engineers, Inc. (HCE)/36-3287225/jsnape@hccemail.org to Environmental Design International inc.(EDI)/36-3759119/jsnape@envdesigni.com EFFECTIVE June 1, 2023 due to acquisition of HCE by EDI on this date. All work previous to 6/1/23 is Hamilton, while all work after is EDI. We also updated the schedule.

Bridge Category Codes	
BCC	Description
1	New
2	Replacement
3	Rehabilitation
4	Repair
5	Other Bridge Work

Local Public Agency City of Wilmington	County Will	Section Number 11-00044-00-BR	State Job No. P-91-495-11	Project No. BRM-9003(807)
Firm Name Hamilton Consulting Engineers, Inc.	Date 12/29/23	From 01/19/23	To 05/31/23	Invoice No. 10716-1-01

Item	Max Allowable	Rate	Quantity	Total	Remarks
Overtime Premium (See Personnel Summary)					
Mileage		\$0.655	45.00	\$29.48	2/9/23 Site Visit
Total for this Period				\$29.48	

Kankakee over Forked Creek Timesheets dtd. 2.7.23 - 5.25.23

City of Wilmington BRM - 9003(807) (HCE10716-01)

Date	Phase Description	Activity	Units/Hours
Howard Hamilton			4.00
02/07/23	Phase I Engineering Contract IDOT Project No. BRM-9003(807) Phase I Engineering	Project Management	1.00
05/16/23	Phase I Engineering Contract IDOT Project No. BRM-9003(807) Phase I Engineering	Meetings, preparation and follow-up	1.25
05/17/23	Phase I Engineering Contract IDOT Project No. BRM-9003(807) Phase I Engineering	Meetings, preparation and follow-up	1.00
05/24/23	Phase I Engineering Contract IDOT Project No. BRM-9003(807) Phase I Engineering	Meetings, preparation and follow-up	0.75
Jeffrey Snape			4.25
02/07/23	Phase I Engineering Contract IDOT Project No. BRM-9003(807) Phase I Engineering	Project Management	0.50
02/27/23	Phase I Engineering Contract IDOT Project No. BRM-9003(807) Phase I Engineering	Telephone Calls and Email Correspondence	0.25
03/06/23	Phase I Engineering Contract IDOT Project No. BRM-9003(807) Phase I Engineering	Meetings, preparation and follow-up	1.00
05/15/23	Phase I Engineering Contract IDOT Project No. BRM-9003(807) Phase I Engineering	Telephone Calls and Email Correspondence	0.50
05/16/23	Phase I Engineering Contract IDOT Project No. BRM-9003(807) Phase I Engineering	Telephone Calls and Email Correspondence	1.00
05/25/23	Phase I Engineering Contract IDOT Project No. BRM-9003(807) Phase I Engineering	Telephone Calls and Email Correspondence	1.00
Michael Buiting			3.00
02/09/23	Phase I Engineering Contract IDOT Project No. BRM-9003(807) Phase I Engineering	Data Collection	3.00
Kristen Hamilton			1.50
03/06/23	Phase I Engineering Contract IDOT Project No. BRM-9003(807) Phase I Engineering	Project Management	1.00
05/03/23	Phase I Engineering Contract IDOT Project No. BRM-9003(807) Phase I Engineering	Project Management	0.50
Total			12.75

Kankakee over Forked Creek Timesheets dtd. 2.7.23 - 5.25.23

City of Wilmington BRM - 9003(807) (HCE10716-01)

Date	Phase Description	Activity	Units/Hours
------	-------------------	----------	-------------

The timesheets submitted reflect all time charged to the subject Contract. Days not included in the timesheets do not have any time charged.

Kristen Hamilton / Principal I

 1-3-24

Howard Hamilton/Principal II

 1-3-24

Jeffrey T. Snape / Project Engineer I

 1/24/24

Michael G. Bunting/Project Engineer II

 1/3/24

Invoice #23IL021

Quigg Engineering Inc.
1845 South Main St.
Jacksonville, IL 62650
217-245-5375

HAMILTON CONSULTING ENGINEERS, INC.
3230 EXECUTIVE DRIVE
JOLIET, IL 60431

Invoice date: 6/10/2023

January 19, 2023 - May 31, 2023	Invoice Number	Invoice Date	Amount
HAMILTON CONSULTING ENGINEERS, INC.			
23IL021 City of Wilmington - Hamilton - Kankakee St. Arch Bridge BCR TSL			
44 hrs. Completed Bridge Inspection field work	23IL02101	6/10/2023	6,328.14
	Invoice Total		6,328.14



QUIGG ENGINEERING INC

HAMILTON CONSULTING ENGINEERS, INC.

Project **23IL021 Hamilton Consulting Engineers Inc.-Wilmington Kankakee St. Arch Bridge BCR TSL**

Invoice number **23IL02101**

Date **08/23/2023**

David R. Booher

Timesheet Date: 05/20/2023

Project	Phase	Activity	Employee Type	Sun-14	Mon-15	Tue-16	Wed-17	Thu-18	Fri-19	Sat-20	Total
23IL021 Hamilton Consulting Engineers Inc.-Wilmington Kankakee St. Arch Bridge BCR TSL	Phase I BCR	Coordination	Engineer VI			1.00					1.00
Regular total				0.00	0.00	1.00	0.00	0.00	0.00	0.00	1.00
Timesheet total				0.00	0.00	1.00	0.00	0.00	0.00	0.00	1.00

Employee submitted	David R. Booher	05/23/2023
Supervisor approved	Todd A. Welz	05/23/2023
Accounting approved	Lindsey James	05/23/2023

Timesheet Date: 05/13/2023

Project	Phase	Activity	Employee Type	Sun-07	Mon-08	Tue-09	Wed-10	Thu-11	Fri-12	Sat-13	Total
23IL021 Hamilton Consulting Engineers Inc.-Wilmington Kankakee St. Arch Bridge BCR TSL	Phase I BCR	Coordination	Engineer VI				1.00	1.00			2.00
Regular total				0.00	0.00	0.00	1.00	1.00	0.00	0.00	2.00
Timesheet total				0.00	0.00	0.00	1.00	1.00	0.00	0.00	2.00

Employee submitted	David R. Booher	05/16/2023
Supervisor approved	Todd A. Welz	05/16/2023
Accounting approved	Lindsey James	05/16/2023

Timesheet Date: 05/06/2023

Project	Phase	Activity	Employee Type	Sun-30	Mon-01	Tue-02	Wed-03	Thu-04	Fri-05	Sat-06	Total
23IL021 Hamilton Consulting Engineers Inc.-Wilmington Kankakee St. Arch Bridge BCR TSL	Phase I BCR	Coordination	Engineer VI				1.00				1.00
Regular total				0.00	0.00	0.00	1.00	0.00	0.00	0.00	1.00
Timesheet total				0.00	0.00	0.00	1.00	0.00	0.00	0.00	1.00

Employee submitted	David R. Booher	05/08/2023
Supervisor approved	Julian I. Gnatenco	05/08/2023
Accounting approved	Lindsey James	05/08/2023

Timesheet Date: 04/15/2023

Project	Phase	Activity	Employee Type	Sun-09	Mon-10	Tue-11	Wed-12	Thu-13	Fri-14	Sat-15	Total
23IL021 Hamilton Consulting Engineers Inc.-Wilmington Kankakee St. Arch Bridge BCR TSL	Phase I BCR	Design Calculations	Engineer VI		1.00		2.00				3.00
Regular total				0.00	1.00	0.00	2.00	0.00	0.00	0.00	3.00
Timesheet total				0.00	1.00	0.00	2.00	0.00	0.00	0.00	3.00

Employee submitted	David R. Booher	04/17/2023
Supervisor approved	Julian I. Gnatenco	04/18/2023
Accounting approved	Lindsey James	04/19/2023



QUIGG ENGINEERING INC

HAMILTON CONSULTING ENGINEERS, INC.

Project **23IL021 Hamilton Consulting Engineers Inc.-Wilmington Kankakee St. Arch Bridge BCR TSL**

Invoice number **23IL02101**

Date **08/23/2023**

Megan Littleton

Timesheet Date: 05/20/2023

Project	Phase	Activity	Employee Type	Sun-14	Mon-15	Tue-16	Wed-17	Thu-18	Fri-19	Sat-20	Total
23IL021 Hamilton Consulting Engineers Inc.-Wilmington Kankakee St. Arch Bridge BCR TSL	Administration	Invoice	Accounting Associate						1.00		1.00
Regular total				0.00	0.00	0.00	0.00	0.00	1.00	0.00	1.00
Timesheet total				0.00	0.00	0.00	0.00	0.00	1.00	0.00	1.00

Employee submitted	Megan Littleton	05/19/2023
Supervisor approved	Rebecca K. Upchurch	05/23/2023
Accounting approved	Lindsey James	05/23/2023

Michael D. Cima

Timesheet Date: 05/27/2023

Project	Phase	Activity	Employee Type	Sun-21	Mon-22	Tue-23	Wed-24	Thu-25	Fri-26	Sat-27	Total
23IL021 Hamilton Consulting Engineers Inc.-Wilmington Kankakee St. Arch Bridge BCR TSL	Phase I BCR	Design Services	Engineer VI					0.25			0.25
Regular total				0.00	0.00	0.00	0.00	0.25	0.00	0.00	0.25
Timesheet total				0.00	0.00	0.00	0.00	0.25	0.00	0.00	0.25

Employee submitted	Michael D. Cima	05/25/2023
Supervisor approved	Todd A. Welz	05/30/2023
Accounting approved	Lindsey James	05/30/2023

Timesheet Date: 05/20/2023

Project	Phase	Activity	Employee Type	Sun-14	Mon-15	Tue-16	Wed-17	Thu-18	Fri-19	Sat-20	Total
23IL021 Hamilton Consulting Engineers Inc.-Wilmington Kankakee St. Arch Bridge BCR TSL	Phase I BCR	Design Services	Engineer VI			0.25					0.25
Regular total				0.00	0.00	0.25	0.00	0.00	0.00	0.00	0.25
Timesheet total				0.00	0.00	0.25	0.00	0.00	0.00	0.00	0.25

Employee submitted	Michael D. Cima	05/18/2023
Supervisor approved	Todd A. Welz	05/22/2023
Accounting approved	Lindsey James	05/22/2023

Timesheet Date: 05/13/2023

Project	Phase	Activity	Employee Type	Sun-07	Mon-08	Tue-09	Wed-10	Thu-11	Fri-12	Sat-13	Total
23IL021 Hamilton Consulting Engineers Inc.-Wilmington Kankakee St. Arch Bridge BCR TSL	Phase I BCR	Design Services	Engineer VI				0.50				0.50
Regular total				0.00	0.00	0.00	0.50	0.00	0.00	0.00	0.50
Timesheet total				0.00	0.00	0.00	0.50	0.00	0.00	0.00	0.50

Employee submitted	Michael D. Cima	05/12/2023
Supervisor approved	Todd A. Welz	05/16/2023
Accounting approved	Lindsey James	05/16/2023



QUIGG ENGINEERING INC

HAMILTON CONSULTING ENGINEERS, INC.

Project **23IL021 Hamilton Consulting Engineers Inc.-Wilmington Kankakee St. Arch Bridge BCR TSL**

Invoice number 23IL02101

Date 08/23/2023

Michael D. Cima

Timesheet Date: 04/29/2023

Project	Phase	Activity	Employee Type	Sun-23	Mon-24	Tue-25	Wed-26	Thu-27	Fri-28	Sat-29	Total
23IL021 Hamilton Consulting Engineers Inc.-Wilmington Kankakee St. Arch Bridge BCR TSL	Phase I BCR	Coordination	Engineer VI					0.25			0.25
Regular total				0.00	0.00	0.00	0.00	0.25	0.00	0.00	0.25
Timesheet total				0.00	0.00	0.00	0.00	0.25	0.00	0.00	0.25

Employee submitted	Michael D. Cima	04/28/2023
Supervisor approved	Julian I. Gnatenco	05/01/2023
Accounting approved	Lindsey James	05/02/2023

Timesheet Date: 04/15/2023

Project	Phase	Activity	Employee Type	Sun-09	Mon-10	Tue-11	Wed-12	Thu-13	Fri-14	Sat-15	Total
23IL021 Hamilton Consulting Engineers Inc.-Wilmington Kankakee St. Arch Bridge BCR TSL	Phase I BCR	Coordination	Engineer VI			0.25					0.25
Regular total				0.00	0.00	0.25	0.00	0.00	0.00	0.00	0.25
Timesheet total				0.00	0.00	0.25	0.00	0.00	0.00	0.00	0.25

Employee submitted	Michael D. Cima	04/16/2023
Supervisor approved	Julian I. Gnatenco	04/18/2023
Accounting approved	Lindsey James	04/19/2023

Rebecca L. Stocker

Timesheet Date: 03/25/2023

Project	Phase	Activity	Employee Type	Sun-19	Mon-20	Tue-21	Wed-22	Thu-23	Fri-24	Sat-25	Total
23IL021 Hamilton Consulting Engineers Inc.-Wilmington Kankakee St. Arch Bridge BCR TSL	Administration	Invoice	Administrative Principal						0.50		0.50
Regular total				0.00	0.00	0.00	0.00	0.00	0.50	0.00	0.50
Timesheet total				0.00	0.00	0.00	0.00	0.00	0.50	0.00	0.50

Employee submitted	Rebecca L. Stocker	03/24/2023
Supervisor approved	Rebecca L. Stocker	03/24/2023
Accounting approved	Rebecca L. Stocker	03/24/2023

Robert P. Whiteside

Timesheet Date: 05/20/2023

Project	Phase	Activity	Employee Type	Sun-14	Mon-15	Tue-16	Wed-17	Thu-18	Fri-19	Sat-20	Total
23IL021 Hamilton Consulting Engineers Inc.-Wilmington Kankakee St. Arch Bridge BCR TSL	Phase I BCR	PH1 TSL	Engineer III			1.50					1.50
Regular total				0.00	0.00	1.50	0.00	0.00	0.00	0.00	1.50
Timesheet total				0.00	0.00	1.50	0.00	0.00	0.00	0.00	1.50



QUIGG ENGINEERING INC

HAMILTON CONSULTING ENGINEERS, INC.

Project **23IL021 Hamilton Consulting Engineers Inc.-Wilmington Kankakee St. Arch Bridge BCR TSL**

Invoice number 23IL02101

Date 08/23/2023

Robert P. Whiteside

Timesheet Date: 05/20/2023

Employee submitted	Robert P. Whiteside	05/22/2023
Supervisor approved	Michael D. Cima	05/22/2023
Accounting approved	Lindsey James	05/22/2023

Timesheet Date: 05/13/2023

Project	Phase	Activity	Employee Type	Sun-07	Mon-08	Tue-09	Wed-10	Thu-11	Fri-12	Sat-13	Total
23IL021 Hamilton Consulting Engineers Inc.-Wilmington Kankakee St. Arch Bridge BCR TSL	Phase I BCR	PH1 TSL	Engineer III		4.75	3.00	1.00	0.50			9.25
Regular total				0.00	4.75	3.00	1.00	0.50	0.00	0.00	9.25
Timesheet total				0.00	4.75	3.00	1.00	0.50	0.00	0.00	9.25

Employee submitted	Robert P. Whiteside	05/12/2023
Supervisor approved	Michael D. Cima	05/13/2023
Accounting approved	Lindsey James	05/15/2023

Timesheet Date: 04/29/2023

Project	Phase	Activity	Employee Type	Sun-23	Mon-24	Tue-25	Wed-26	Thu-27	Fri-28	Sat-29	Total
23IL021 Hamilton Consulting Engineers Inc.-Wilmington Kankakee St. Arch Bridge BCR TSL	Phase I BCR	PH1 TSL	Engineer III		1.00			0.50			1.50
23IL021 Hamilton Consulting Engineers Inc.-Wilmington Kankakee St. Arch Bridge BCR TSL	Phase I Field Inspection	PH1 TSL	Engineer III		1.00		8.50				9.50
Regular total				0.00	2.00	0.00	8.50	0.50	0.00	0.00	11.00
Timesheet total				0.00	2.00	0.00	8.50	0.50	0.00	0.00	11.00

Employee submitted	Robert P. Whiteside	04/28/2023
Supervisor approved	Michael D. Cima	04/30/2023
Accounting approved	Lindsey James	05/01/2023

Timesheet Date: 04/15/2023

Project	Phase	Activity	Employee Type	Sun-09	Mon-10	Tue-11	Wed-12	Thu-13	Fri-14	Sat-15	Total
23IL021 Hamilton Consulting Engineers Inc.-Wilmington Kankakee St. Arch Bridge BCR TSL	Phase I BCR	PH1 TS WARR	Engineer III			0.50	3.50				4.00
Regular total				0.00	0.00	0.50	3.50	0.00	0.00	0.00	4.00
Timesheet total				0.00	0.00	0.50	3.50	0.00	0.00	0.00	4.00

Employee submitted	Robert P. Whiteside	04/14/2023
Supervisor approved	Michael D. Cima	04/14/2023
Accounting approved	Lindsey James	04/17/2023

Zoe Davidson

Timesheet Date: 04/29/2023

Project	Phase	Activity	Employee Type	Sun-23	Mon-24	Tue-25	Wed-26	Thu-27	Fri-28	Sat-29	Total
23IL021 Hamilton Consulting Engineers Inc.-Wilmington Kankakee St. Arch Bridge BCR TSL	Phase I Field Inspection	Field Study	Engineer I				8.25				8.25



QUIGG ENGINEERING INC

HAMILTON CONSULTING ENGINEERS, INC.

Project **23IL021 Hamilton Consulting Engineers Inc.-Wilmington Kankakee St. Arch Bridge BCR TSL**

Invoice number **23IL02101**

Date **08/23/2023**

Zoe Davidson

Timesheet Date: 04/29/2023

Regular total	0.00	0.00	0.00	8.25	0.00	0.00	0.00	8.25
Timesheet total	0.00	0.00	0.00	8.25	0.00	0.00	0.00	8.25

Employee submitted	Zoe Davidson	04/28/2023
Supervisor approved	Michael D. Cima	04/30/2023
Accounting approved	Lindsey James	05/01/2023



Expense Report

Quigg Engineering Inc.

Friday, May 19, 2023
Page 1

Name: Robert P. Whiteside	Report Dates:	Report Amounts:
Description:	Begin Date 4/23/2023	Advance Amount 0.00
Notes:	End Date 5/8/2023	Total Amount 192.57

Date	ID	Project Description	Phase	Expense Item	Payee	Units	Rate	Amount	Reference	Credit Card	Import	Prsnl
4/26/2023	23IL021	Hamilton Consulting Engineers Inc.- Wilmington Kankakee St. Arch Bridge BCR TSL	Vehicle Own/Lsd	Company Vehicle Mileage		294.00	0.6550	192.57		Company Vehicle	<input type="checkbox"/>	<input type="checkbox"/>
Total:								192.57				
Advance:								0.00				
Credit Card:								-192.57				
Personal:								0.00				
Net Due:								0.00				

Employee Signature

Date

Manager Signature

Date

Approval:	Name	Approved
Supervisor:	Lindsey James	05/10/23
Accounting:	Lindsey James	05/10/23

Invoice
0549060

Wiss, Janney, Elstner Associates, Inc.
Engineers, Architects, Materials Scientists
Please remit to: PO Box 204645
Dallas, TX 75320-4645
TIN: 36-2757956

6/15/2023

Hamilton Consulting Engineers, Inc.

Attn: Accounts Payable
3230 Executive Drive
Joliet, IL 60431

Project: 2021.0594.0 May 1, 2023 - May 31, 2023

KANKAKEE STREET OVER FORKED CREEK BRIDGE (CITY OF WILMINGTON, IL) IDOT PROJECT BRM-9003(807)
INSPECTION, ANALYSIS, AND LOAD TESTING OF LOCAL ARCH BRIDGE

26.25 hrs. Structural analysis; material examination; reporting; project coordination \$4,914.52

Invoice Total: \$ 4,914.52



Wiss, Janney, Elstner Associates, Inc.
330 Pfingsten Road
Northbrook, Illinois 60062
847.272.7400 tel
www.wje.com

June 15, 2023

Illinois Department of Transportation

RE: Certification of Timecards

To whom it may concern:

I hereby certify that in my position as Payroll Manager for Wiss, Janney, Elstner Associates, Inc. (WJE), I Candace Malone have conducted an examination of the timecard payroll records of WJE.

Based on the foregoing, I hereby certify on behalf of WJE that the timecards following on the attached invoice are complete and accurate timecards for the employee.

This information is confidential and to be used solely for support of pay rates for projects with the City of Chicago Department of Transportation. Any other use of the information contained herein is strictly prohibited without the express written consent of the management of Wiss, Janney, Elstner Associates, Inc.

Sincerely,

WISS, JANNEY, ELSTNER ASSOCIATES, INC.

Candace R. Malone

Candace Malone
Payroll Manager

Detailed Timesheet for the Period Ending 5/7/2023

Wednesday, June 7, 2023

Wiss, Janney, Elstner Associates, Inc.

2:57:49 PM

Employee **1962** **Jarrett, Matthew W.**

		Total Hr	Mon 5/1	Tue 5/2	Wed 5/3	Thu 5/4	Fri 5/5	Sat 5/6	Sun 5/7
2021.0594.0	KANKAKEE STREET OVER FORKED CREEK BRIDGE								
00	BASE								

Client: Hamilton Consulting Engineers, Inc.

Reg	3.00	2.00	1.00					
OIL07								

5/1 Review AASHTO MBE load test guidance; discuss load test procedure

5/2 Review arch calculations

Detailed Timesheet for the Period Ending 5/14/2023

Wednesday, June 7, 2023

Wiss, Janney, Elstner Associates, Inc.

2:58:16 PM

Employee **1962** **Jarrett, Matthew W.**

		Total Hr	Mon 5/8	Tue 5/9	Wed 5/10	Thu 5/11	Fri 5/12	Sat 5/13	Sun 5/14
2021.0594.0	KANKAKEE STREET OVER FORKED CREEK BRIDGE								
00	BASE								

Client: Hamilton Consulting Engineers, Inc.

01L07

Reg	5.00	2.50		2.00	.50			

- 5/8 Arch analysis and research
- 5/10 Discuss arch analysis and load test procedure w/ Quigg
- 5/11 Discuss material sample examination work

Detailed Timesheet for the Period Ending 5/21/2023

Wednesday, June 7, 2023

2:58:34 PM

Wiss, Janney, Elstner Associates, Inc.

Employee **1962** **Jarrett, Matthew W.**

		Total Hr	Mon 5/15	Tue 5/16	Wed 5/17	Thu 5/18	Fri 5/19	Sat 5/20	Sun 5/21
2021.0594.0	KANKAKEE STREET OVER FORKED CREEK BRIDGE								
00	BASE								

Client: Hamilton Consulting Engineers, Inc.

01L07	Reg	1.00		1.00					
-------	------------	------	--	------	--	--	--	--	--

5/16 Conference call regarding load testing

Detailed Timesheet for the Period Ending 5/28/2023

Wednesday, June 7, 2023

Wiss, Janney, Elstner Associates, Inc.

2:58:57 PM

Employee **1962** **Jarrett, Matthew W.**

		Total Hr	Mon 5/22	Tue 5/23	Wed 5/24	Thu 5/25	Fri 5/26	Sat 5/27	Sun 5/28
2021.0594.0	KANKAKEE STREET OVER FORKED CREEK BRIDGE								
00	BASE								

Client: Hamilton Consulting Engineers, Inc.

0IL07

Reg	1.50		.50		1.00			

5/23 Discuss load test and analysis

5/25 Zoom meeting to discuss bridge

Detailed Timesheet for the Period Ending 5/14/2023

Wednesday, June 7, 2023

Wiss, Janney, Elstner Associates, Inc.

2:59:26 PM

Employee **1820** **Lauer, Steven L.**

		Total Hr	Mon 5/8	Tue 5/9	Wed 5/10	Thu 5/11	Fri 5/12	Sat 5/13	Sun 5/14
2021.0594.0	KANKAKEE STREET OVER FORKED CREEK BRIDGE								
00	BASE								

Client: Hamilton Consulting Engineers, Inc.

01L07	Reg	.50	.50						
-------	------------	-----	-----	--	--	--	--	--	--

5/8 Load test discussion and planning.

Detailed Timesheet for the Period Ending 6/4/2023

Wednesday, June 7, 2023

Wiss, Janney, Elstner Associates, Inc.

3:00:23 PM

Employee **3121** **Knudtsen, Jonathan**

		Total Hr	Mon 5/29	Tue 5/30	Wed 5/31	Thu 6/1	Fri 6/2	Sat 6/3	Sun 6/4
2021.0594.0	KANKAKEE STREET OVER FORKED CREEK BRIDGE								
00	BASE								
	SOR09								
	Reg	.50		.50					
	5/30 Analysis								

Client: Hamilton Consulting Engineers, Inc.

Detailed Timesheet for the Period Ending 5/14/2023

Wednesday, June 7, 2023

Wiss, Janney, Elstner Associates, Inc.

3:00:47 PM

Employee **2383** **Reo, George A.**

	Total Hr	Mon	Tue	Wed	Thu	Fri	Sat	Sun
		5/8	5/9	5/10	5/11	5/12	5/13	5/14
2021.0594.0								
00								
KANKAKEE STREET OVER FORKED CREEK BRIDGE		Client: Hamilton Consulting Engineers, Inc.						
BASE								

0IL09

Reg	.50				.50			
------------	-----	--	--	--	-----	--	--	--

5/11 Review of Samples

Detailed Timesheet for the Period Ending 5/14/2023

Wednesday, June 7, 2023

Wiss, Janney, Elstner Associates, Inc.

3:01:23 PM

Employee **2806** **Sherry, Samuel T.**

		Total Hr	Mon 5/8	Tue 5/9	Wed 5/10	Thu 5/11	Fri 5/12	Sat 5/13	Sun 5/14
2021.0594.0	KANKAKEE STREET OVER FORKED CREEK BRIDGE								
00	BASE								

Client: Hamilton Consulting Engineers, Inc.

0IL09

Reg							
	.25	.25					

5/8 Project talk with matthew

Invoice
054615

Wiss, Janney, Elstner Associates, Inc.
Engineers, Architects, Materials Scientists
Please remit to: PO Box 204645
Dallas, TX 75320-4645
TIN: 36-2757956

5/12/2023

Hamilton Consulting Engineers, Inc.

Attn: Accounts Payable
3230 Executive Drive
Joliet, IL 60431

Project: 2021.0594.0 March 6, 2023 - April 30, 2023

KANKAKEE STREET OVER FORKED CREEK BRIDGE (CITY OF WILMINGTON, IL) IDOT PROJECT BRM-9003(807)
INSPECTION, ANALYSIS, AND LOAD TESTING OF LOCAL ARCH BRIDGE

58.25 hrs. Performed initial site visit and preliminary structural analysis	\$10,380.97
Coring Equipment Rental and service truck rental	<u>200.00</u>
	\$10,580.97

Invoice Total: \$10,580.97



Wiss, Janney, Elstner Associates, Inc.
 330 Pfingsten Road
 Northbrook, Illinois 60062
 847.272.7400 tel | 847.291.4813 fax
 www.wje.com

Kankakee Street over Forked Creek Bridge (City of Wilmington)
IDOT Project BRM-9003(807)

Invoice No. 1

Date: 4/30/2023

Project Information:

WJE No. - 2021.0594.0
 Proj. Manager - M. Jarrett

Project Address:

Hamilton Consulting Engineers, Inc.
 Attn: Jeffrey Snape
 3230 Executive Drive
 Joliet, IL 60431

Item	Qty	Unit	Description	Rate (\$/unit)	Amount
1	1	Day	Coring Equipment Rental (4/21/2023)	\$100.00	\$ 100.00
2	1	Day	Ford F450-1 Service Truck w/ 10kW Gen (4/21/2023)	\$100.00	\$ 100.00
3					\$ -
4					\$ -
5					\$ -
6					\$ -
7					\$ -
8					\$ -
9					\$ -
10					\$ -
11					\$ -
12					\$ -
13					\$ -
14					\$ -
15					\$ -
				Total	\$ 200.00

Atlanta | Austin | Boston | Chicago | Cleveland | Dallas | Denver | Detroit | Doylestown | Honolulu | Houston | Indianapolis
 London | Los Angeles | Milwaukee | Minneapolis | New Haven | Northbrook (HQ) | New York | Philadelphia | Pittsburgh
 Portland | Princeton | Raleigh | San Antonio | San Diego | San Francisco | Seattle | South Florida | Washington, DC



Wiss, Janney, Elstner Associates, Inc.
330 Pvingsten Road
Northbrook, Illinois 60062
847.272.7400 tel
www.wje.com

May 12, 2023

Illinois Department of Transportation

RE: Certification of Timecards

To whom it may concern:

I hereby certify that in my position as Payroll Manager for Wiss, Janney, Elstner Associates, Inc. (WJE), I Candace Malone have conducted an examination of the timecard payroll records of WJE.

Based on the foregoing, I hereby certify on behalf of WJE that the timecards following on the attached invoice are complete and accurate timecards for the employee.

This information is confidential and to be used solely for support of pay rates for projects with the City of Chicago Department of Transportation. Any other use of the information contained herein is strictly prohibited without the express written consent of the management of Wiss, Janney, Elstner Associates, Inc.

Sincerely,

WISS, JANNEY, ELSTNER ASSOCIATES, INC.

Candace R. Malone

Candace Malone
Payroll Manager

Detailed Timesheet for the Period Ending 3/12/2023

Thursday, May 11, 2023
12:55:54 PM

Wiss, Janney, Elstner Associates, Inc.

Employee **1962** **Jarrett, Matthew W.**

		Total Hr	Mon 3/6	Tue 3/7	Wed 3/8	Thu 3/9	Fri 3/10	Sat 3/11	Sun 3/12
2021.0594.0	KANKAKEE STREET OVER FORKED CREEK BRIDGE								
0P	PROPOSAL								
01L07	Reg	1.00	1.00						
	3/6 Call with Hamilton; proposal								

Client: Hamilton Consulting Engineers, Inc.

Detailed Timesheet for the Period Ending 3/26/2023

Thursday, May 11, 2023

12:57:06 PM

Wiss, Janney, Elstner Associates, Inc.

Employee **1962** **Jarrett, Matthew W.**

		Total Hr	Mon 3/20	Tue 3/21	Wed 3/22	Thu 3/23	Fri 3/24	Sat 3/25	Sun 3/26
2021.0594.0	KANKAKEE STREET OVER FORKED CREEK BRIDGE								
0P	PROPOSAL								

Client: Hamilton Consulting Engineers, Inc.

0IL07	Reg	1.00		1.00					
	3/21 Coordinate upcoming field work; discuss preliminary analysis								

Detailed Timesheet for the Period Ending 4/16/2023

Thursday, May 11, 2023

1:00:28 PM

Wiss, Janney, Elstner Associates, Inc.

Employee **1962** **Jarrett, Matthew W.**

		Total Hr	Mon 4/10	Tue 4/11	Wed 4/12	Thu 4/13	Fri 4/14	Sat 4/15	Sun 4/16
2021.0594.0	KANKAKEE STREET OVER FORKED CREEK BRIDGE								
00	BASE								

Client: Hamilton Consulting Engineers, Inc.

01L07	Reg	1.00		.50		.50			
-------	------------	------	--	-----	--	-----	--	--	--

4/11 Site visit prep; discuss preliminary analysis

4/13 Coordinate field visit

Detailed Timesheet for the Period Ending 4/23/2023

Thursday, May 11, 2023

1:00:49 PM

Wiss, Janney, Elstner Associates, Inc.

Employee **1962** **Jarrett, Matthew W.**

		Total Hr	Mon 4/17	Tue 4/18	Wed 4/19	Thu 4/20	Fri 4/21	Sat 4/22	Sun 4/23
2021.0594.0	KANKAKEE STREET OVER FORKED CREEK BRIDGE								
00	BASE								

Client: Hamilton Consulting Engineers, Inc.

01L07	Reg	11.25		.50	.75		10.00		
-------	------------	-------	--	-----	-----	--	-------	--	--

4/18 Prep for site visit

4/19 Prep for site visit; arch analysis

4/21 Bridge site visit: measurements and sampling; pack and unpack equipment

Detailed Timesheet for the Period Ending 4/30/2023

Thursday, May 11, 2023

Wiss, Janney, Elstner Associates, Inc.

1:01:18 PM

Employee **1962** **Jarrett, Matthew W.**

		Total Hr	Mon 4/24	Tue 4/25	Wed 4/26	Thu 4/27	Fri 4/28	Sat 4/29	Sun 4/30
2021.0594.0	KANKAKEE STREET OVER FORKED CREEK BRIDGE								
00	BASE								

Client: Hamilton Consulting Engineers, Inc.

0IL07

Reg						
	1.50		.75			75

4/25 Review site visit findings

4/28 Discuss arch analysis

Detailed Timesheet for the Period Ending 3/26/2023

Thursday, May 11, 2023

1:01:37 PM

Wiss, Janney, Elstner Associates, Inc.

Employee **2806** **Sherry, Samuel T.**

Total Hr	Mon 3/20	Tue 3/21	Wed 3/22	Thu 3/23	Fri 3/24	Sat 3/25	Sun 3/26
----------	----------	----------	----------	----------	----------	----------	----------

2021.0594.0
OP

KANKAKEE STREET OVER FORKED CREEK BRIDGE
PROPOSAL

Client: Hamilton Consulting Engineers, Inc.

OIL09

Reg	1.00		1.00				
-----	------	--	------	--	--	--	--

3/21 Work discussion with matthew and folks about GPR

Detailed Timesheet for the Period Ending 4/16/2023

Thursday, May 11, 2023

1:02:12 PM

Wiss, Janney, Elstner Associates, Inc.

Employee **2806** **Sherry, Samuel T.**

Total Hr	Mon 4/10	Tue 4/11	Wed 4/12	Thu 4/13	Fri 4/14	Sat 4/15	Sun 4/16
---------------------	-------------	-------------	-------------	-------------	-------------	-------------	-------------

2021.0594.0
00

KANKAKEE STREET OVER FORKED CREEK BRIDGE
BASE

Client: Hamilton Consulting Engineers, Inc.

01L09

Reg	11.50		.50	8.00	3.00			
------------	-------	--	-----	------	------	--	--	--

4/11 Initial analysis work

4/12 Analysis of structure

4/13 Analysis of structure

Detailed Timesheet for the Period Ending 4/23/2023

Thursday, May 11, 2023

Wiss, Janney, Elstner Associates, Inc.

1:02:28 PM

Employee **2806** **Sherry, Samuel T.**

		Total Hr	Mon 4/17	Tue 4/18	Wed 4/19	Thu 4/20	Fri 4/21	Sat 4/22	Sun 4/23
2021.0594.0	KANKAKEE STREET OVER FORKED CREEK BRIDGE								
00	BASE								

Client: Hamilton Consulting Engineers, Inc.

0IL09	Reg	14.00		6.00			8.00		
-------	------------	-------	--	------	--	--	------	--	--

4/18 Arch talk with Matthew, Emails about work, and some analysis calcs.

4/21 Bridge Inspection and Limestone Cores

Detailed Timesheet for the Period Ending 4/23/2023

Thursday, May 11, 2023

1:03:32 PM

Wiss, Janney, Elstner Associates, Inc.

Employee **0948** **Beltran, J. Consuelo**

Total Hr	Mon 4/17	Tue 4/18	Wed 4/19	Thu 4/20	Fri 4/21	Sat 4/22	Sun 4/23
----------	----------	----------	----------	----------	----------	----------	----------

2021.0594.0
00

KANKAKEE STREET OVER FORKED CREEK BRIDGE
BASE

Client: Hamilton Consulting Engineers, Inc.

OIL15

Reg							
8.50					8.50		

4/21 packing equipment & cores

Detailed Timesheet for the Period Ending 4/30/2023

Thursday, May 11, 2023

1:03:54 PM

Wiss, Janney, Elstner Associates, Inc.

Employee **0948** **Beltran, J. Consuelo**

		Total Hr	Mon 4/24	Tue 4/25	Wed 4/26	Thu 4/27	Fri 4/28	Sat 4/29	Sun 4/30
2021.0594.0	KANKAKEE STREET OVER FORKED CREEK BRIDGE								
00	BASE								

Client: Hamilton Consulting Engineers, Inc.

Reg	1.00	1.00						
0IL15								

4/24 unpack equipment

LOCAL AGENCY COST PLUS FIXED FEE INVOICE

Date 01/23/24 Invoice No. 1(EDI23606)

To
 City of Wilmington
 Attention To
 Deputy City Clerk
 Address
 1165 W. Water Street
 City State Zip Code
 Wilmington IL 60481

From
 Environmental Design International inc.
 Address
 33 West Monroe St., Suite 1825
 City State Zip Code
 Chicago IL 60603

Local Public Agency County Section Number State Job No. Project No.
 City of Wilmington Will 11-00044-00-BR P-91-495-11 BRM-9003(807)

For Professional Service performed as set forth in Agreement dated: 08/12/11 Consultant's Job No. 8012.001 Overhead Rate 172.85
 & Supplemental Agreement(s) dated: 1/19/2023 FHWA Authorization Date

1) Invoice Period From: 06/01/23 To: 12/31/23

	This Invoice	Previously Invoiced	Earned to Date	Max Allowable
2) Maximum Payable				\$237,656.00
3) Direct Salaries	\$1,440.41	\$17,947.78	\$19,388.19	\$33,440.00
4) QC/QA				
5) Payroll & Overhead				
this invoice 172.8500%	\$2,489.75	\$30,946.96	\$33,436.71	\$66,499.00
average 0.0000%				
6.) Fixed Fee= 8.8540%	\$1,288.17	\$8,127.89	\$9,416.06	\$14,549.00
7) Direct Costs Prime		\$646.25	\$646.25	\$1,625.00
8) Services by others				
Wiss, Janney, Elstner Assoc. <input type="checkbox"/> DBE?	\$6,948.18	\$15,495.19	\$22,443.37	\$43,751.00
Quigg Engineering, Inc. <input checked="" type="checkbox"/> DBE?	\$4,221.87	\$29,337.57	\$33,559.44	\$72,142.00
Midwest Testing <input type="checkbox"/> DBE?		\$7,200.00	\$7,200.00	\$5,650.00
9) Total invoiced for project including this invoice			\$126,090.02	
10) Previously Invoiced		\$109,701.64		
11) Payment Due this invoice	\$16,388.38			

I have reviewed the invoice and found it agrees with the executed Engineering Agreement for this project. The percent of work shown as completed on this invoice matches the attached Progress Report signed by the project engineer.

Approved Local Public Agency Rep. Signature & Date

I certify the costs included in this invoice have been expended and the percent of work shown as completed on this invoice is correct. As the prime consultant, work invoices included in this invoice for work done by others were reviewed and approved.

Consultant
 Environmental Design International inc.

By Signature & Date
 1-23-24

Name
 Howard J. Hamilton, PE, CFM, CPESC
 Title
 Director of Engineering

Local Public Agency City of Wilmington	County Will	Section Number 11-00044-00-BR	State Job No. P-91-495-11	Project No. BRM-9003(807)
Firm Name Environmental Design International inc.	Date 01/23/24	From 06/01/23	To 12/31/23	Invoice No. 1(EDI23606)

(For Local Public Agency Use Only)

On Schedule
 Behind Schedule

Comments

Project Manager/Engineer Signature & Date

Submitted By
Howard J. Hamilton, PE, CFM, CPESC

Representing
Environmental Design International inc.

For Subconsultant's Progress Report:
Approved By



1-23-24

Prime Consultant

Work this period

Preliminary report from WJE re: bridge status and possible next steps - review and discuss, contact expert in Pennsylvania for guidance, follow up with City.

Anticipated work next period

Meet with City to discuss options and budget.

Personnel Summary for Period

Employee	Classification	Regular Hours	Overtime Premium Hours	Hours	Rate	Direct Salaries Total	Premium Rate	Overtime Premium Cost
Kristen Hamilton	Administrative Support II				\$48.08	\$0.00		
Howard Hamilton	Senior Consulting Engineer	1.75		1.75	\$72.12	\$126.21		
Jeffrey Snape	Senior Consulting Engineer	19.25		19.25	\$68.27	\$1,314.20		
Michael Buiting	Enginner II				\$39.90	\$0.00		
Lee Koehler	Surveyor III				\$51.92	\$0.00		
David Stroh	CADD Manager				\$49.52	\$0.00		
Miriam Richardsor	Admin Support II				\$35.00	\$0.00		
Mary Beth Pressley	Admin Support II				\$30.25	\$0.00		
Total Labor excluding QC/QA		21		21		\$1,440.41	Total	

QC/QA

Employee	Classification	Regular Hours	Overtime Premium Hours	Hours	Rate	Direct Salaries Total	Premium Rate	Overtime Premium Cost
Total Labor for QC/QA								
TOTAL LABOR						\$1,440.41		

Direct Cost Summary for Period

Item	Max Allowable	Rate	Quantity	Total	Remarks
Overtime Premium (See Personnel Summary)					

Local Public Agency	County	Section Number	State Job No.	Project No.
City of Wilmington	Will	11-00044-00-BR	P-91-495-11	BRM-9003(807

Firm Name	Date	From	To	Invoice No.
Environmental Design International inc.	01/23/24	06/01/23	12/31/23	1(EDI23606)

Item	Max Allowable	Rate	Quantity	Total	Remarks
Mileage					
			Total for this Period		

Employee Timesheet

Name: Howard Hamilton



Timesheet Ended Date: 6/30/2023

Project ID	Project Description	Phase Description	Activity	Employee Type	Sat-24	Sun-25	Mon-26	Tue-27	Wed-28	Thu-29	Fri-30	Total
8012.001	Kankakee Street Over Forked Creek-Bridge Improvements (10716-1)	Phase I Engineering Contract IDOT Project No. BRM-9003 (807) Phase I Engineering	Billable Labor	Civil Engineer	0.00	0.00	0.00	0.00	0.00	1.25	0.00	1.25
Total Hours					0.00	0.00	0.00	0.00	0.00	1.25	0.00	1.25

Employee submitted	Miriam Richardson	09/26/2023
Supervisor approved	Celeste N. Baker	09/26/2023
Accounting approved	Jane Winters	09/26/2023

Employee Timesheet

Name: Howard Hamilton



Timesheet Ended Date: 6/16/2023

Project ID	Project Description	Phase Description	Activity	Employee Type	Sat-10	Sun-11	Mon-12	Tue-13	Wed-14	Thu-15	Fri-16	Total
8012.001	Kankakee Street Over Forked Creek-Bridge Improvements (10716-1)	Phase I Engineering Contract IDOT Project No. BRM-9003 (807) Phase I Engineering	Billable Labor	Civil Engineer	0.00	0.00	0.00	0.00	0.00	0.50	0.00	0.50
Total Hours					0.00	0.00	0.00	0.00	0.00	0.50	0.00	0.50

Employee submitted	Miriam Richardson	09/26/2023
Supervisor approved	Celeste N. Baker	09/26/2023
Accounting approved	Jane Winters	09/26/2023

Employee Timesheet



Name: Jeffrey Snape

Timesheet Ended Date: 7/14/2023

Project ID	Project Description	Phase Description	Activity	Employee Type	Sat-08	Sun-09	Mon-10	Tue-11	Wed-12	Thu-13	Fri-14	Total
8012.001	Kankakee Street Over Forked Creek-Bridge Improvements (10716-1)	Phase I Engineering Contract IDOT Project No. BRM-9003 (807) Phase I Engineering	Billable Labor	Senior Professional	0.00	0.00	0.25	0.00	0.00	0.00	0.00	0.25
Total Hours					0.00	0.00	0.25	0.00	0.00	0.00	0.00	0.25

Employee submitted	Miriam Richardson	09/26/2023
Supervisor approved	Celeste N. Baker	09/26/2023
Accounting approved	Jane Winters	09/26/2023

Employee Timesheet



Name: Jeffrey Snape

Timesheet Ended Date: 6/30/2023

Project ID	Project Description	Phase Description	Activity	Employee Type	Sat-24	Sun-25	Mon-26	Tue-27	Wed-28	Thu-29	Fri-30	Total
8012.001	Kankakee Street Over Forked Creek-Bridge Improvements (10716-1)	Phase I Engineering Contract IDOT Project No. BRM-9003 (807) Phase I Engineering	Billable Labor	Senior Professional	0.00	0.00	0.00	0.00	0.00	2.00	0.00	2.00
Total Hours					0.00	0.00	0.00	0.00	0.00	2.00	0.00	2.00

Employee submitted	Miriam Richardson	09/26/2023
Supervisor approved	Celeste N. Baker	09/26/2023
Accounting approved	Jane Winters	09/26/2023

Employee Timesheet



Name: Jeffrey Snape

Timesheet Ended Date: 6/16/2023

Project ID	Project Description	Phase Description	Activity	Employee Type	Sat-10	Sun-11	Mon-12	Tue-13	Wed-14	Thu-15	Fri-16	Total
8012.001	Kankakee Street Over Forked Creek-Bridge Improvements (10716-1)	Phase I Engineering Contract IDOT Project No. BRM-9003 (807) Phase I Engineering	Billable Labor	Senior Professional	0.00	0.00	0.00	0.50	0.00	0.00	0.00	0.50
Total Hours					0.00	0.00	0.00	0.50	0.00	0.00	0.00	0.50

Employee submitted	Miriam Richardson	09/26/2023
Supervisor approved	Celeste N. Baker	09/26/2023
Accounting approved	Jane Winters	09/26/2023

Employee Timesheet



Name: Jeffrey Snape

Timesheet Ended Date: 7/7/2023

Project ID	Project Description	Phase Description	Activity	Employee Type	Sat-01	Sun-02	Mon-03	Tue-04	Wed-05	Thu-06	Fri-07	Total
8012.001	Kankakee Street Over Forked Creek-Bridge Improvements (10716-1)	Phase I Engineering Contract IDOT Project No. BRM-9003 (807) Phase I Engineering	Billable Labor	Senior Professional	0.00	0.00	0.00	0.00	1.00	0.00	0.00	1.00
Total Hours					0.00	0.00	0.00	0.00	1.00	0.00	0.00	1.00

Employee submitted	Miriam Richardson	09/26/2023
Supervisor approved	Celeste N. Baker	09/26/2023
Accounting approved	Jane Winters	09/26/2023

Employee Timesheet



Name: Jeffrey Snape

Timesheet Ended Date: 8/11/2023

Project ID	Project Description	Phase Description	Activity	Employee Type	Sat-05	Sun-06	Mon-07	Tue-08	Wed-09	Thu-10	Fri-11	Total
8012.001	Kankakee Street Over Forked Creek-Bridge Improvements (10716-1)	Phase I Engineering Contract IDOT Project No. BRM-9003 (807) Phase I Engineering	Billable Labor	Senior Professional	0.00	0.00	0.00	0.00	0.00	1.00	0.00	1.00
Total Hours					0.00	0.00	0.00	0.00	0.00	1.00	0.00	1.00

Employee submitted	Jeffrey Snape	08/14/2023
Supervisor approved	Howard Hamilton	08/14/2023
Accounting approved	Jane Winters	08/15/2023

Employee Timesheet



Name: Jeffrey Snape

Timesheet Ended Date: 8/18/2023

Project ID	Project Description	Phase Description	Activity	Employee Type	Sat-12	Sun-13	Mon-14	Tue-15	Wed-16	Thu-17	Fri-18	Total
8012.001	Kankakee Street Over Forked Creek-Bridge Improvements (10716-1)	Phase I Engineering Contract IDOT Project No. BRM-9003 (807) Phase I Engineering	Billable Labor	Senior Professional	0.00	0.00	0.00	0.50	0.00	0.00	0.00	0.50
Total Hours					0.00	0.00	0.00	0.50	0.00	0.00	0.00	0.50

Employee submitted	Jeffrey Snape	08/18/2023
Supervisor approved	Howard Hamilton	08/21/2023
Accounting approved	Jane Winters	08/22/2023

Employee Timesheet



Name: Jeffrey Snape

Timesheet Ended Date: 9/15/2023

Project ID	Project Description	Phase Description	Activity	Employee Type	Sat-09	Sun-10	Mon-11	Tue-12	Wed-13	Thu-14	Fri-15	Total
8012.001	Kankakee Street Over Forked Creek-Bridge Improvements (10716-1)	Phase I Engineering Contract IDOT Project No. BRM-9003 (807) Phase I Engineering	Billable Labor	Senior Professional	0.00	0.00	0.00	0.00	0.50	0.00	0.00	0.50
Total Hours					0.00	0.00	0.00	0.00	0.50	0.00	0.00	0.50

Employee submitted	Jeffrey Snape	09/18/2023
Supervisor approved	Celeste N. Baker	09/19/2023
Accounting approved	Celeste N. Baker	09/19/2023

Employee Timesheet



Name: Jeffrey Snape

Timesheet Ended Date: 9/22/2023

Project ID	Project Description	Phase Description	Activity	Employee Type	Sat-16	Sun-17	Mon-18	Tue-19	Wed-20	Thu-21	Fri-22	Total
8012.001	Kankakee Street Over Forked Creek-Bridge Improvements (10716-1)	Phase I Engineering Contract IDOT Project No. BRM-9003 (807) Phase I Engineering	Billable Labor	Senior Professional	0.00	0.00	1.00	0.00	0.00	0.00	0.00	1.00
Total Hours					0.00	0.00	1.00	0.00	0.00	0.00	0.00	1.00

Employee submitted	Jeffrey Snape	09/25/2023
Supervisor approved	Howard Hamilton	09/25/2023
Accounting approved	Celeste N. Baker	10/02/2023

Employee Timesheet



Name: Jeffrey Snape

Timesheet Ended Date: 10/6/2023

Project ID	Project Description	Phase Description	Activity	Employee Type	Sat-30	Sun-01	Mon-02	Tue-03	Wed-04	Thu-05	Fri-06	Total
8012.001	Kankakee Street Over Forked Creek-Bridge Improvements (10716-1)	Phase I Engineering Contract IDOT Project No. BRM-9003 (807) Phase I Engineering	Billable Labor	Senior Professional	0.00	0.00	0.00	1.00	2.50	0.00	0.00	3.50
Total Hours					0.00	0.00	0.00	1.00	2.50	0.00	0.00	3.50

Employee submitted	Jeffrey Snape	10/09/2023
Supervisor approved	Howard Hamilton	10/09/2023
Accounting approved	Celeste N. Baker	10/18/2023

Employee Timesheet



Name: Jeffrey Snape

Timesheet Ended Date: 11/10/2023

Project ID	Project Description	Phase Description	Activity	Employee Type	Sat-04	Sun-05	Mon-06	Tue-07	Wed-08	Thu-09	Fri-10	Total
8012.001	Kankakee Street Over Forked Creek-Bridge Improvements (10716-1)	Phase I Engineering Contract IDOT Project No. BRM-9003 (807) Phase I Engineering	Billable Labor	Senior Professional	0.00	0.00	0.00	0.00	0.00	0.00	0.50	0.50
Total Hours					0.00	0.00	0.00	0.00	0.00	0.00	0.50	0.50

Employee submitted	Jeffrey Snape	11/13/2023
Supervisor approved	Howard Hamilton	11/13/2023
Accounting approved	Jane Winters	11/15/2023

Employee Timesheet



Name: Jeffrey Snape

Timesheet Ended Date: 11/17/2023

Project ID	Project Description	Phase Description	Activity	Employee Type	Sat-11	Sun-12	Mon-13	Tue-14	Wed-15	Thu-16	Fri-17	Total
8012.001	Kankakee Street Over Forked Creek-Bridge Improvements (10716-1)	Phase I Engineering Contract IDOT Project No. BRM-9003 (807) Phase I Engineering	Billable Labor	Senior Professional	0.00	0.00	0.00	1.50	2.00	0.00	0.00	3.50
Total Hours					0.00	0.00	0.00	1.50	2.00	0.00	0.00	3.50

Employee submitted	Jeffrey Snape	11/20/2023
Supervisor approved	Howard Hamilton	11/20/2023
Accounting approved	Jane Winters	11/28/2023

Employee Timesheet



Name: Jeffrey Snape

Timesheet Ended Date: 11/24/2023

Project ID	Project Description	Phase Description	Activity	Employee Type	Sat-18	Sun-19	Mon-20	Tue-21	Wed-22	Thu-23	Fri-24	Total
8012.001	Kankakee Street Over Forked Creek-Bridge Improvements (10716-1)	Phase I Engineering Contract IDOT Project No. BRM-9003 (807) Phase I Engineering	Billable Labor	Senior Professional	0.00	0.00	0.00	0.00	2.00	0.00	2.00	4.00
Total Hours					0.00	0.00	0.00	0.00	2.00	0.00	2.00	4.00

Employee submitted	Jeffrey Snape	11/27/2023
Supervisor approved	Howard Hamilton	11/28/2023
Accounting approved	Jane Winters	11/28/2023

Employee Timesheet



Name: Jeffrey Snape

Timesheet Ended Date: 12/22/2023

Project ID	Project Description	Phase Description	Activity	Employee Type	Sat-16	Sun-17	Mon-18	Tue-19	Wed-20	Thu-21	Fri-22	Total
8012.001	Kankakee Street Over Forked Creek-Bridge Improvements (10716-1)	Phase I Engineering Contract IDOT Project No. BRM-9003 (807) Phase I Engineering	Billable Labor	Senior Professional	0.00	0.00	0.00	1.00	0.00	0.00	0.00	1.00
Total Hours					0.00	0.00	0.00	1.00	0.00	0.00	0.00	1.00

Employee submitted	Jeffrey Snape	12/21/2023
Supervisor approved	Howard Hamilton	12/22/2023
Accounting approved	Celeste N. Baker	12/26/2023

Invoice
0551563

Wiss, Janney, Elstner Associates, Inc.
Engineers, Architects, Materials Scientists
Please remit to: PO Box 204645
Dallas, TX 75320-4645
TIN: 36-2757956

7/11/2023

Environmental Design International, Inc.

Attn: Accounts Payable
3230 Executive Drive
Joliet, IL 60431

Project: 2021.0594.0

KANKAKEE STREET OVER FORKED CREEK BRIDGE (CITY OF WILMINGTON, IL) IDOT PROJECT BRM-9003(807)
INSPECTION, ANALYSIS, AND LOAD TESTING OF LOCAL ARCH BRIDGE

41.75 hrs. Structural analysis and material examination; reporting; project meetings	\$6,547.18
Wagner Petrographic-supplies; shipping	<u>401.00</u>
	\$6,948.18
Invoice Total:	\$6,948.18

Payor: Shipper

Ref.#3:

Fuel Surcharge - FedEx has applied a fuel surcharge of 14.00% to this shipment.
Distance Based Pricing, Zone 6

Automation	INET	Sender	Recipient	
Tracking ID	772308238430	Sara Eriksen	Wagner Petrographic	
Service Type	FedEx Priority Overnight	WISS JANNEY ELSTNER ASSOCIATES	122 N 1800 W	
Package Type	FedEx Box	330 Pflingsten Road	LINDON UT 84042 US	
Zone	06	NORTHBROOK IL 60062 US		
Packages	1			
Rated Weight	3.0 lbs, 1.4 kgs	Transportation Charge		104.52
Delivered	Jun 01, 2023 09:55	Discount		-52.26
Svc Area	A2	Grace Discount		-3.14
Signed by	J.JAVIER	Fuel Surcharge		6.88
FedEx Use	000000000/1574/_	Total Charge	USD	\$56.00

102367

WAGNER PETROGRAPHIC LLC

122 NORTH 1800 WEST STE 7

LINDON, UTAH 84042

1-800-828-0686

Invoice

Date	Invoice #
6/9/2023	19640

Bill to:

WJE

330 PFINGSTEN RD.

NORTHBROOK, IL 60062

FOR GEORGE REO
2021.0594

P.O. No.	Terms	Due Date	Ship Via	Project#
	Net 30	7/9/2023	FEDEX	
Description	Qty	Price Each	Amount	
3"X2" THIN SECTION W/COVER GLASS	2	47.00	94.00	
3X2" BLUE EPOXY VACUUM IMPREGNATION	2	6.00	12.00	
ULTRA HIGH PRESSURE IMPREGNATION 600-1200 PSI	2	8.00	16.00	
ULTRA THIN SECTION <20-25 MICRONS 3X2	2	8.00	16.00	
EXPRESS SERVICE CHARGE 2 DAY + 150%		207.00	207.00	

FW: Invoice 19640 from WAGNER PETR...

Reo, George
To: Accounts Payable Mon 2:59 PM

CASEY

Click here to download pictures. To help protect your privacy, Outlook prevented automatic download of some pictures in this message.

Inv_19640_from_WAGNER_PETROGRAPHIC_LLC_2...
69 KB

Hello,

Please pay this invoice per terms. It's approved and can be charged to 2021.0594.

Thanks,
George

From: scott@wagnerpetrographic.com

5200.03

www.wagnerpetrographic.com

CREDIT CARDS ACCEPTED

Total	\$345.00
Payments/Credits	\$0.00
Balance Due	\$345.00



Wiss, Janney, Elstner Associates, Inc.
330 Pfingsten Road
Northbrook, Illinois 60062
847.272.7400 tel
www.wje.com

July 7, 2023

Illinois Department of Transportation

RE: Certification of Timecards

To whom it may concern:

I hereby certify that in my position as Payroll Manager for Wiss, Janney, Elstner Associates, Inc. (WJE), I Candace Malone have conducted an examination of the timecard payroll records of WJE.

Based on the foregoing, I hereby certify on behalf of WJE that the timecards following on the attached invoice are complete and accurate timecards for the employee.

This information is confidential and to be used solely for support of pay rates for projects with the City of Chicago Department of Transportation. Any other use of the information contained herein is strictly prohibited without the express written consent of the management of Wiss, Janney, Elstner Associates, Inc.

Sincerely,

WISS, JANNEY, ELSTNER ASSOCIATES, INC.

Candace R. Malone

Candace Malone
Payroll Manager

Detailed Timesheet for the Period Ending 6/18/2023

Friday, July 7, 2023

Wiss, Janney, Elstner Associates, Inc.

11:01:17 AM

Employee **1091** **Itle, Kenneth M.**

Total Hr	Mon 6/12	Tue 6/13	Wed 6/14	Thu 6/15	Fri 6/16	Sat 6/17	Sun 6/18
----------	----------	----------	----------	----------	----------	----------	----------

2021.0594.0
00

KANKAKEE STREET OVER FORKED CREEK BRIDGE
BASE

Client: Hamilton Consulting Engineers, Inc.

UIL05

Reg	1.00	1.00						
-----	------	------	--	--	--	--	--	--

6/12 Review letter

Detailed Timesheet for the Period Ending 6/11/2023

Friday, July 7, 2023

Wiss, Janney, Elstner Associates, Inc.

11:01:35 AM

Employee **1962** **Jarrett, Matthew W.**

Total Hr	Mon 6/5	Tue 6/6	Wed 6/7	Thu 6/8	Fri 6/9	Sat 6/10	Sun 6/11
----------	---------	---------	---------	---------	---------	----------	----------

2021.0594.0
00

KANKAKEE STREET OVER FORKED CREEK BRIDGE
BASE

Client: Hamilton Consulting Engineers, Inc.

01L07

Reg	4.50		1.00	3.00	.50			
-----	------	--	------	------	-----	--	--	--

6/6 Discuss analysis and material samples

6/7 Review/revise report

6/8 Assemble report for review

Detailed Timesheet for the Period Ending 6/18/2023

Friday, July 7, 2023

Wiss, Janney, Elstner Associates, Inc.

11:01:57 AM

Employee **1962** **Jarrett, Matthew W.**

Total Hr	Mon 6/12	Tue 6/13	Wed 6/14	Thu 6/15	Fri 6/16	Sat 6/17	Sun 6/18
-------------	-------------	-------------	-------------	-------------	-------------	-------------	-------------

2021.0594.0
00

KANKAKEE STREET OVER FORKED CREEK BRIDGE
BASE

Client: Hamilton Consulting Engineers, Inc.

01L07

Reg	1.00			1.00			
------------	------	--	--	------	--	--	--

6/14 Finalize and send letter report

Detailed Timesheet for the Period Ending 7/2/2023

Friday, July 7, 2023

Wiss, Janney, Elstner Associates, Inc.

11:02:13 AM

Employee **1962** **Jarrett, Matthew W.**

	Total Hr	Mon	Tue	Wed	Thu	Fri	Sat	Sun
		6/26	6/27	6/28	6/29	6/30	7/1	7/2
2021.0594.0								
00								
01L07								
KANKAKEE STREET OVER FORKED CREEK BRIDGE								
BASE								
Reg	1.00				1.00			
6/29 Meeting to discuss report and possible bridge load test								

Client: Hamilton Consulting Engineers, Inc.

Detailed Timesheet for the Period Ending 6/11/2023

Friday, July 7, 2023

11:02:39 AM

Wiss, Janney, Elstner Associates, Inc.

Employee **3121** **Knudtsen, Jonathan**

Total Hr	Mon 6/5	Tue 6/6	Wed 6/7	Thu 6/8	Fri 6/9	Sat 6/10	Sun 6/11
----------	---------	---------	---------	---------	---------	----------	----------

2021.0594.0
00

KANKAKEE STREET OVER FORKED CREEK BRIDGE
BASE

Client: Hamilton Consulting Engineers, Inc.

SOR09

Reg	.50		.50				
------------	-----	--	-----	--	--	--	--

6/6 Analysis

Detailed Timesheet for the Period Ending 6/4/2023

Friday, July 7, 2023

Wiss, Janney, Elstner Associates, Inc.

11:03:21 AM

Employee **2383** **Reo, George A.**

	Total Hr	Mon	Tue	Wed	Thu	Fri	Sat	Sun
		5/29	5/30	5/31	6/1	6/2	6/3	6/4

2021.0594.0
00

KANKAKEE STREET OVER FORKED CREEK BRIDGE
BASE

Client: Hamilton Consulting Engineers, Inc.

01L09

Reg								
					.50			

6/2 Petro exam

Detailed Timesheet for the Period Ending 6/11/2023

Friday, July 7, 2023

Wiss, Janney, Elstner Associates, Inc.

11:03:57 AM

Employee **2383** **Reo, George A.**

Total Hr	Mon 6/5	Tue 6/6	Wed 6/7	Thu 6/8	Fri 6/9	Sat 6/10	Sun 6/11
----------	---------	---------	---------	---------	---------	----------	----------

2021.0594.0
00

KANKAKEE STREET OVER FORKED CREEK BRIDGE
BASE

Client: Hamilton Consulting Engineers, Inc.

01L09

Reg	9.50		4.00	4.00	1.00	.50		
-----	------	--	------	------	------	-----	--	--

6/6 Petro exam and report drafting

6/7 Petro exam and report drafting; report revisions

6/8 Report drafting

6/9 Report revisions

Detailed Timesheet for the Period Ending 6/4/2023

Friday, July 7, 2023

11:04:19 AM

Wiss, Janney, Elstner Associates, Inc.

Employee **2806** **Sherry, Samuel T.**

Total Hr	Mon 5/29	Tue 5/30	Wed 5/31	Thu 6/1	Fri 6/2	Sat 6/3	Sun 6/4
----------	----------	----------	----------	---------	---------	---------	---------

2021.0594.0
00

KANKAKEE STREET OVER FORKED CREEK BRIDGE
BASE

Client: Hamilton Consulting Engineers, Inc.

01L09

Reg	7.00				5.25	1.75		
------------	------	--	--	--	------	------	--	--

6/1 Report writing

6/2 Report writing

Detailed Timesheet for the Period Ending 6/11/2023

Friday, July 7, 2023

Wiss, Janney, Elstner Associates, Inc.

11:04:36 AM

Employee **2806** **Sherry, Samuel T.**

Total Hr	Mon 6/5	Tue 6/6	Wed 6/7	Thu 6/8	Fri 6/9	Sat 6/10	Sun 6/11
----------	---------	---------	---------	---------	---------	----------	----------

2021.0594.0
00

KANKAKEE STREET OVER FORKED CREEK BRIDGE
BASE

Client: Hamilton Consulting Engineers, Inc.

0IL09

Reg	6.00	8.50		1.25			
-----	------	------	--	------	--	--	--

6/5 Report writing

6/6 Report writing

6/8 Report writing

Detailed Timesheet for the Period Ending 6/11/2023

Thursday, December 28, 2023

Wiss, Janney, Elstner Associates, Inc.

11:35:49 AM

Employee **1947** **Hou, Xiaoqiang**

Total Hr	Mon 6/5	Tue 6/6	Wed 6/7	Thu 6/8	Fri 6/9	Sat 6/10	Sun 6/11
----------	---------	---------	---------	---------	---------	----------	----------

2021.0594.0
FF

KANKAKEE STREET OVER FORKED CREEK BRIDGE
FIXED FEE

Client: Environmental Design International, Inc.

01L07

Reg	1.00			1.00			
-----	------	--	--	------	--	--	--

6/7 reviewing petro memo/samples per George's request

Invoice

Quigg Engineering Inc.
1845 South Main St.
Jacksonville, IL 62650
217-245-5375

Environmental Design International inc.
3230 EXECUTIVE DRIVE
JOLIET, IL 60431

Invoice date 9/6/2023

June 1, 2023 - August 31, 2023

	Invoice Number	Invoice Date	Amount
Environmental Design International inc. 23IL021 City of Wilmington - Hamilton/EDI - Kankakee St. Arch Bridge BCR TSL 26.5 hrs. completed draft BCR and submitted to prime	23IL02102	9/6/2023	4,221.87
	Invoice Total		<u>4,221.87</u>



QUIGG ENGINEERING INC

HAMILTON CONSULTING ENGINEERS, INC.

Project **23IL021 Hamilton Consulting Engineers Inc.-Wilmington Kankakee St. Arch Bridge BCR TSL**

Invoice number 23IL02102

Date 09/06/2023

David R. Booher

Timesheet Date: 08/26/2023

Project	Phase	Activity	Employee Type	Sun-20	Mon-21	Tue-22	Wed-23	Thu-24	Fri-25	Sat-26	Total
23IL021 Hamilton Consulting Engineers Inc.-Wilmington Kankakee St. Arch Bridge BCR TSL	Phase I BCR	Coordination	Engineer VI					1.00			1.00
Regular total				0.00	0.00	0.00	0.00	1.00	0.00	0.00	1.00
Timesheet total				0.00	0.00	0.00	0.00	1.00	0.00	0.00	1.00

Employee submitted	David R. Booher	08/28/2023
Supervisor approved	Todd A. Welz	08/28/2023
Accounting approved	Lindsey James	08/29/2023

James Cray

Timesheet Date: 07/29/2023

Project	Phase	Activity	Employee Type	Sun-23	Mon-24	Tue-25	Wed-26	Thu-27	Fri-28	Sat-29	Total
23IL021 Hamilton Consulting Engineers Inc.-Wilmington Kankakee St. Arch Bridge BCR TSL	Phase I BCR	CADD	Engineer Technician I		0.75	5.50					6.25
Regular total				0.00	0.75	5.50	0.00	0.00	0.00	0.00	6.25
Timesheet total				0.00	0.75	5.50	0.00	0.00	0.00	0.00	6.25

Employee submitted	James Cray	07/28/2023
Supervisor approved	Michael D. Cima	07/30/2023
Accounting approved	Lindsey James	07/31/2023

Michael D. Cima

Timesheet Date: 08/26/2023

Project	Phase	Activity	Employee Type	Sun-20	Mon-21	Tue-22	Wed-23	Thu-24	Fri-25	Sat-26	Total
23IL021 Hamilton Consulting Engineers Inc.-Wilmington Kankakee St. Arch Bridge BCR TSL	Phase I BCR	Design Services	Engineer VI			0.25					0.25
Regular total				0.00	0.00	0.25	0.00	0.00	0.00	0.00	0.25
Timesheet total				0.00	0.00	0.25	0.00	0.00	0.00	0.00	0.25

Employee submitted	Michael D. Cima	08/26/2023
Supervisor approved	Todd A. Welz	08/28/2023
Accounting approved	Lindsey James	08/29/2023

Timesheet Date: 08/19/2023

Project	Phase	Activity	Employee Type	Sun-13	Mon-14	Tue-15	Wed-16	Thu-17	Fri-18	Sat-19	Total
23IL021 Hamilton Consulting Engineers Inc.-Wilmington Kankakee St. Arch Bridge BCR TSL	Phase I BCR	Design Services	Engineer VI		0.25						0.25
Regular total				0.00	0.25	0.00	0.00	0.00	0.00	0.00	0.25
Timesheet total				0.00	0.25	0.00	0.00	0.00	0.00	0.00	0.25



QUIGG ENGINEERING INC

HAMILTON CONSULTING ENGINEERS, INC.

Project 23IL021 Hamilton Consulting Engineers Inc.-Wilmington Kankakee St. Arch Bridge BCR TSL

Invoice number 23IL02102

Date 09/06/2023

Michael D. Cima

Timesheet Date: 08/19/2023

Employee submitted	Michael D. Cima	08/18/2023
Supervisor approved	Todd A. Welz	08/21/2023
Accounting approved	Lindsey James	08/22/2023

Timesheet Date: 08/12/2023

Project	Phase	Activity	Employee Type	Sun-06	Mon-07	Tue-08	Wed-09	Thu-10	Fri-11	Sat-12	Total
23IL021 Hamilton Consulting Engineers Inc.-Wilmington Kankakee St. Arch Bridge BCR TSL	Phase I BCR	Design Services	Engineer VI			0.50	0.25				0.75
Regular total				0.00	0.00	0.50	0.25	0.00	0.00	0.00	0.75
Timesheet total				0.00	0.00	0.50	0.25	0.00	0.00	0.00	0.75

Employee submitted	Michael D. Cima	08/10/2023
Supervisor approved	Rebecca L. Stocker	08/15/2023
Accounting approved	Lindsey James	08/15/2023

Timesheet Date: 08/05/2023

Project	Phase	Activity	Employee Type	Sun-30	Mon-31	Tue-01	Wed-02	Thu-03	Fri-04	Sat-05	Total
23IL021 Hamilton Consulting Engineers Inc.-Wilmington Kankakee St. Arch Bridge BCR TSL	Phase I BCR	Design Services	Engineer VI	0.25							0.25
Regular total				0.25	0.00	0.00	0.00	0.00	0.00	0.00	0.25
Timesheet total				0.25	0.00	0.00	0.00	0.00	0.00	0.00	0.25

Employee submitted	Michael D. Cima	08/04/2023
Supervisor approved	Todd A. Welz	08/07/2023
Accounting approved	Lindsey James	08/08/2023

Timesheet Date: 07/29/2023

Project	Phase	Activity	Employee Type	Sun-23	Mon-24	Tue-25	Wed-26	Thu-27	Fri-28	Sat-29	Total
23IL021 Hamilton Consulting Engineers Inc.-Wilmington Kankakee St. Arch Bridge BCR TSL	Phase I BCR	Design Services	Engineer VI		0.50						0.50
Regular total				0.00	0.50	0.00	0.00	0.00	0.00	0.00	0.50
Timesheet total				0.00	0.50	0.00	0.00	0.00	0.00	0.00	0.50

Employee submitted	Michael D. Cima	07/28/2023
Supervisor approved	Todd A. Welz	07/31/2023
Accounting approved	Lindsey James	07/31/2023

Timesheet Date: 07/08/2023

Project	Phase	Activity	Employee Type	Sun-02	Mon-03	Tue-04	Wed-05	Thu-06	Fri-07	Sat-08	Total
23IL021 Hamilton Consulting Engineers Inc.-Wilmington Kankakee St. Arch Bridge BCR TSL	Phase I Field Inspection	Meetings	Engineer VI						0.50		0.50
Regular total				0.00	0.00	0.00	0.00	0.00	0.50	0.00	0.50
Timesheet total				0.00	0.00	0.00	0.00	0.00	0.50	0.00	0.50



QUIGG ENGINEERING INC

HAMILTON CONSULTING ENGINEERS, INC.

Project **23IL021 Hamilton Consulting Engineers Inc.-Wilmington Kankakee St. Arch Bridge BCR TSL**

Invoice number 23IL02102

Date 09/06/2023

Michael D. Cima

Timesheet Date: 07/08/2023

Employee submitted	Michael D. Cima	07/07/2023
Supervisor approved	Todd A. Welz	07/11/2023
Accounting approved	Lindsey James	07/11/2023

Timesheet Date: 07/01/2023

Project	Phase	Activity	Employee Type	Sun-25	Mon-26	Tue-27	Wed-28	Thu-29	Fri-30	Sat-01	Total
23IL021 Hamilton Consulting Engineers Inc.-Wilmington Kankakee St. Arch Bridge BCR TSL	Phase I Field Inspection	Meetings	Engineer VI					1.00			1.00
Regular total				0.00	0.00	0.00	0.00	1.00	0.00	0.00	1.00
Timesheet total				0.00	0.00	0.00	0.00	1.00	0.00	0.00	1.00

Employee submitted	Michael D. Cima	07/01/2023
Supervisor approved	Todd A. Welz	07/03/2023
Accounting approved	Rebecca L. Stocker	07/05/2023

Rebecca L. Stocker

Timesheet Date: 07/22/2023

Project	Phase	Activity	Employee Type	Sun-16	Mon-17	Tue-18	Wed-19	Thu-20	Fri-21	Sat-22	Total
23IL021 Hamilton Consulting Engineers Inc.-Wilmington Kankakee St. Arch Bridge BCR TSL	Administration	Invoice	Administrative Principal			1.00					1.00
Regular total				0.00	0.00	1.00	0.00	0.00	0.00	0.00	1.00
Timesheet total				0.00	0.00	1.00	0.00	0.00	0.00	0.00	1.00

Employee submitted	Rebecca L. Stocker	07/20/2023
Supervisor approved	Rebecca L. Stocker	07/20/2023
Accounting approved	Rebecca L. Stocker	07/20/2023

Robert P. Whiteside

Timesheet Date: 08/26/2023

Project	Phase	Activity	Employee Type	Sun-20	Mon-21	Tue-22	Wed-23	Thu-24	Fri-25	Sat-26	Total
23IL021 Hamilton Consulting Engineers Inc.-Wilmington Kankakee St. Arch Bridge BCR TSL	Phase I BCR	PH1 TSL	Engineer IV		0.50						0.50
Regular total				0.00	0.50	0.00	0.00	0.00	0.00	0.00	0.50
Timesheet total				0.00	0.50	0.00	0.00	0.00	0.00	0.00	0.50

Employee submitted	Robert P. Whiteside	08/25/2023
Supervisor approved	Michael D. Cima	08/27/2023
Accounting approved	Lindsey James	08/28/2023

Timesheet Date: 08/12/2023

Project	Phase	Activity	Employee Type	Sun-06	Mon-07	Tue-08	Wed-09	Thu-10	Fri-11	Sat-12	Total
23IL021 Hamilton Consulting Engineers Inc.-Wilmington Kankakee St. Arch Bridge BCR TSL	Phase I BCR	PH1 TSL	Engineer IV				2.25	0.25			2.50



QUIGG ENGINEERING INC

HAMILTON CONSULTING ENGINEERS, INC.

Project **23IL021 Hamilton Consulting Engineers Inc.-Wilmington Kankakee St. Arch Bridge BCR TSL**

Invoice number 23IL02102

Date 09/06/2023

Robert P. Whiteside

Timesheet Date: 08/12/2023

Regular total	0.00	0.00	0.00	2.25	0.25	0.00	0.00	2.50
Timesheet total	0.00	0.00	0.00	2.25	0.25	0.00	0.00	2.50

Employee submitted	Robert P. Whiteside	08/11/2023
Supervisor approved	Michael D. Cima	08/14/2023
Accounting approved	Lindsey James	08/14/2023

Timesheet Date: 08/05/2023

Project	Phase	Activity	Employee Type	Sun-30	Mon-31	Tue-01	Wed-02	Thu-03	Fri-04	Sat-05	Total
23IL021 Hamilton Consulting Engineers Inc.-Wilmington Kankakee St. Arch Bridge BCR TSL	Phase I BCR	PH1 TSL	Engineer IV		0.50						0.50
Regular total				0.00	0.50	0.00	0.00	0.00	0.00	0.00	0.50
Timesheet total				0.00	0.50	0.00	0.00	0.00	0.00	0.00	0.50

Employee submitted	Robert P. Whiteside	08/04/2023
Supervisor approved	Michael D. Cima	08/06/2023
Accounting approved	Lindsey James	08/07/2023

Timesheet Date: 07/29/2023

Project	Phase	Activity	Employee Type	Sun-23	Mon-24	Tue-25	Wed-26	Thu-27	Fri-28	Sat-29	Total
23IL021 Hamilton Consulting Engineers Inc.-Wilmington Kankakee St. Arch Bridge BCR TSL	Phase I BCR	PH1 TSL	Engineer IV		6.25	3.00					9.25
Regular total				0.00	6.25	3.00	0.00	0.00	0.00	0.00	9.25
Timesheet total				0.00	6.25	3.00	0.00	0.00	0.00	0.00	9.25

Employee submitted	Robert P. Whiteside	07/28/2023
Supervisor approved	Michael D. Cima	07/30/2023
Accounting approved	Lindsey James	07/31/2023

Timesheet Date: 07/22/2023

Project	Phase	Activity	Employee Type	Sun-16	Mon-17	Tue-18	Wed-19	Thu-20	Fri-21	Sat-22	Total
23IL021 Hamilton Consulting Engineers Inc.-Wilmington Kankakee St. Arch Bridge BCR TSL	Phase I BCR	PH1 TSL	Engineer IV		2.00						2.00
Regular total				0.00	2.00	0.00	0.00	0.00	0.00	0.00	2.00
Timesheet total				0.00	2.00	0.00	0.00	0.00	0.00	0.00	2.00

Employee submitted	Robert P. Whiteside	07/21/2023
Supervisor approved	Michael D. Cima	07/23/2023
Accounting approved	Lindsey James	07/24/2023