



City of Wilmington
1165 South Water Street
Wilmington, IL 60481

Agenda
Regular City Council Meeting
Wilmington City Hall
Council Chambers
July 17, 2018
7:00 p.m.

I. Call to Order

II. Pledge of Allegiance

III. Roll Call by City Clerk

John Persic, Jr.	Kevin Kirwin
Dennis Vice	Floyd Combes
Lisa Butler	Fran Tutor
Steve Evans	Frank Studer

IV. Approval of Minutes from the July 3, 2018 Regular City Council Meeting

V. Mayor's Report

Announcements: Catfish days begins July 26 ó July 29, 2018

Electronic Recycling ó Second and Fourth Thursday of every month between 5 p.m. and 7 p.m.

VI. Public Comment

(State your full name clearly; limit 5 minutes each per Ordinance 17-10-17-05)

VII. Planning & Zoning Commission

1. Approve the P&Z Commission's recommendation to approve the variance to Allow for an accessory structure within the front yard of Lot 2, West River Road [PIN 03-17-35-401-015-0000]
2. The next scheduled meeting is Thursday, August 2, 2018 at 5:00 p.m.

Posting Date:
7/13/2018 3:19 PM hh

VIII. Committee Reports

A. Buildings, Grounds, Parks, Health & Safety Committee

Co-Chairs – John Persic, Jr. & Steve Evans

1. The next scheduled meeting is Wednesday, August 15, 2018 at 5:30 p.m.

B. Water, Sewer, Streets & Alleys Committee

Co-Chairs – Frank Studer & Kevin Kirwin

1. The next scheduled meeting is Wednesday, August 15, 2018 at 6:00 p.m.

C. Police & ESDA Committee

Co-Chairs – Frank Studer & Fran Tutor

1. The next scheduled meeting is Tuesday, August 14, 2018 at 5:30 p.m.

D. Finance, Administration & Land Acquisition Committee

Co-Chairs – Frank Studer & Fran Tutor

1. Approve the Accounting Reports are Presented by the City Account
2. Approve the Lime Removal Quote as Provided by Continental
3. Approve the Sealing Coating Quote for the Parking Lots at City Hall and Police Department
4. The next scheduled meeting is Tuesday, August 21, 2018 at 6:00 p.m.

E. Ordinance & License Committee

Co-Chairs – Lisa Butler & Floyd Combes

1. Approve Ordinance Regulating for Food Trucks.
2. Approve Ordinance Repealing the Fireworks Sales or Storage Ordinance and Amending the Prohibited Conduct Ordinance to Regulate the Possessions and Sale of Fireworks within the City of Wilmington.
3. Approve Ordinance Amending the Salary of the City Clerk.
4. Approve Ordinance Amending the Ordinance relating to Order of Business for City Council Meetings.

5. Approve Ordinance providing for the Regulation of an Application for Small Wireless Facilities.
6. The next scheduled meeting is Tuesday, August 21, 2018 at 6:00 p.m.

F. Personnel & Collective Bargaining Committee
Co-Chairs – John Persic, Jr. & Dennis Vice

IX. Attorney's Report

X. Adjournment

The next City Council meeting is Tuesday, July 17, 2018 at 7:00 p.m.

DRAFT

**Minutes of the Regular Meeting of the
Wilmington City Council
Wilmington City Hall
1165 South Water Street
Tuesday, July 3, 2018**

Call to Order

The Regular Meeting of the Wilmington City Council on June 19, 2018 was called to order at 7:03 p.m. by Mayor Roy Strong in the Council Chambers of the Wilmington City Hall.

Roll Call

Upon Roll Call by the Clerk the following members of the corporate authorities answered "Here" or "Present":

Aldermen Present Tutor, Butler, Kirwin, Vice, Combes

Alderman Absent Persic, Evans, Studer

Quorum

There being a sufficient number of members of the corporate authorities in attendance to constitute a quorum, the meeting was declared in order.

Other Officials in Attendance

Also, in attendance were the Deputy City Clerk Joie Ziller, City Accountant Kim Doglio, Attorney Bryan Wellner

Approval of Minutes

Alderman Tutor made a motion and Alderman Butler seconded to approve the June 19, 2018 Regular City Council meeting minutes and have them placed on file

Upon roll call, the vote was:

AYES: 5 Vice, Combes, Tutor, Kirwin, Butler

NAYS: 0

The motion carried.

Mayor' Report

Alderman Butler made a motion and Alderman Tutor seconded to approve Resolution No. 2018-10 6 A Resolution by the City of Wilmington City Council in support of the Designation of Route 66 as a National Historic Trail.

Upon roll call, the vote was:

AYES: 5 Vice, Combes, Tutor, Kirwin, Butler

NAYS: 0

The motion carried.

The Mayor announces that Wilmington Police Department National Night Out is August 7th from 6:30 to 8:30 pm at the Wilmington High School

Rick Smith's Building Department report for Jan thru June 2018: 3.1million in permitted work, \$92,073 in permit fees collected, 1 Single Family Home Permit, 1 Four Unit Townhome Permit, 1 Fire Station at Ridgeport Permit, the majority of the work was for residential repairs, reroofing, fences, room additions,

DRAFT

etc., Completed Industrial Products includes a concrete truck scale and equipment support for World Foods (Ridgeport), Notable Commercial Remodels include the Launching Pad (phase 1 completed), Rt 66 Car Museum (completed) and Longest Office Building (in progress)

Public Comment

Grace Elwell, Foxtails Commons, 257 Jennifer Lane, states that the sidewalk has a heave in it, and questions about the sidewalk share and how to get the city to fix it. Also the lights are bad. The Mayor and Alderman will go look over the issues.

Planning & Zoning Commission

The next meeting is scheduled for Thursday, July 12, 2018 at 5:00 p.m.

Committee Reports

Buildings, Grounds, Parks, Health & Safety Committee

The next scheduled meeting is Wednesday, July 11, 2018 at 5:30 p.m.

Water, Sewer, Streets and Alleys Committee

The next scheduled meeting is Wednesday, July 11, 2018 at 6:00 p.m.

Police & ESDA Committee

The next scheduled meeting is Tuesday, July 10, 2018 at 5:30 p.m.

Finance, Administration & Land Acquisition Committee

Alderman Tutor made a motion and Alderman Butler seconded to approve the Accounts Payable Report dated July 3, 2018 in the amount of \$251,984.54 as presented by the City Accountant

Upon roll call, the vote was:

AYES: 5 Vice, Combes, Tutor, Kirwin, Butler

NAYS: 0

The motion carried.

Alderman Tutor made a motion and Alderman Combes seconded to approve Ordinance No. 18-07-03-01 ó An Ordinance Appropriating for all Corporate Purposes for the City of Wilmington, Will County, Illinois for the Fiscal Year Beginning May 1, 2018 and Ending April 30, 2019

Upon roll call, the vote was:

AYES: 5 Vice, Combes, Tutor, Kirwin, Butler

NAYS: 0

The motion carried.

Alderman Tutor announces the review of the City of Wilmington's Non-Binding Letter of Intent to acquire Easement (Buck Property). The Mayor speaks about the how they need the Buck's property for a storm sewer drain. Ridge wants the City to own it so that way if there is a problem they come to us to fix it. Basically they are going to pay to put it in and there will be a road on top of it. Wellner: The Buck's are the owners of record for that parcel. Meeting on July 12 to go over the details. Butler: Who is making the payments of the \$175k Mayor: Ridge pays everything Wellner: the City would be taking on

DRAFT

the liability of having to maintain it over the course of the years. Other than the liability that comes with that, there would be nothing that the City would have to do.

The next scheduled meeting is Tuesday, July 16, 2018 at 6 p.m.

Ordinance & License Committee
Co-Chairs – Floyd Combes & Lisa Butler

The scheduled meeting of Tuesday, July 10, 2018 will need to be rescheduled.

Personnel & Collective Bargaining Committee
Co-Chairs – John Persic Jr.

Nothing at this time

Attorney's Report

Attorney Wellner talks about an act that legislature passed which allows small wireless facilities to be put in any municipality township or otherwise in the rights of way, on utility poles and street polls and then outside of rights a way of any commercial or industrial zoned property. And it pretty much says we don't have the ability to deny them wanting them to put these devices on our property we only have the ability to regulate it and its limited on how we can regulate it. It was passed in June. We can probably take in application fees. Mayor: I got a call from a gentleman who wants to do that. Wellner: The statute provides the exact amount of the fees that we can ask for. I have the ordinance in front of me; it just needs to go thru one last review.

Adjournment

Motion to adjourn the meeting made by Alderman Tutor and seconded by Alderman Kirwin. Upon voice vote, the motion carried. The Regular Meeting of the City of Wilmington City Council held on July 3, 2018 adjourned at 7:20 p.m.

Respectfully submitted,

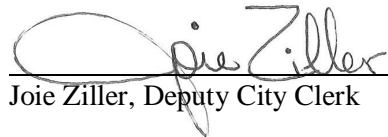

Joie Ziller, Deputy City Clerk

CERTIFICATE OF PUBLICATION

STATE OF ILLINOIS } Ss.
County of Will,

Copy of Notice Herein Referred To

Certificate of the Publisher

Free Press Newspapers certifies that it is the publisher of the The Free Press Advocate

The Free Press Advocate is a secular newspaper, has been continuously published **weekly** for more than fifty (50) weeks prior to the first publication of the attached notice, is published in the city of Wilmington, township of Wilmington, State of Illinois, is of general circulation throughout that county and surrounding area, and is a newspaper as defined by 715 ILCS 5/5. A notice, relating to the matter of: **City of Wilmington to consider variance**

a true copy of which is attached, was published 1 times in The Free Press Advocate, namely one time per week for one successive weeks. The first publication of the notice was made in the newspaper, dated and published on June 20, 2018, and the last publication of the notice was made in the newspaper dated and published on June 20, 2018. This notice was also placed on a statewide public notice website as required by 715 ILCS 5/2.1. In witness, the **Free Press Newspapers** has signed this certificate by **Eric D Fisher**, its publisher, at Wilmington, Illinois, on June 20, 2018.

Free Press Newspapers

By Eric D. Fisher Publisher
Eric D. Fisher

Printer's Fee \$ 30.80

Given under my hand on June 20, 2018.

Janet M. Fisher

Janet M. Fisher, Notary Public

" OFFICIAL SEAL "

Janet M. Fisher

Notary Public, State of Illinois

My Commission Expires 12-15-20

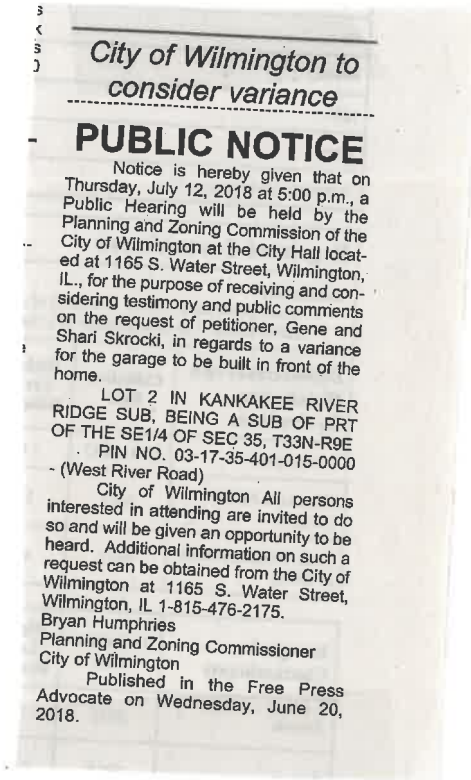



Land Use Petition
City of Wilmington, Illinois

RECEIVED

June 4 '18

CITY OF WILMINGTON

Petitioner: Gene and Shari Skrocki
Address: 2011 Jasmine Dr.
City: Cresthill State: IL Zip: 60403
Phone No.: 815-530-0968 Fax No.: Email: gskrocko@att.net

- Petitioner is the owner of the subject property and is the signer of this petition
Petitioner is the contract purchaser of the subject property and has attached a copy of said contract to this petition
Petitioner is acting on behalf of the owner of the subject property and has attached a letter granting such authority signed by the owner

In the event the property is held in trust, a notarized letter from an authorized trust officer identifying the petitioner as an authorized individual acting on behalf of the beneficiaries and providing the name, address, and percentage of interest of each beneficiary is attached to this executed petition.

Subject Property

Location: Lot 2 West River Road
Size of Property: 140x627.84x143.33x575.75 Tax Parcel No.: 03-17-35-401-015-0000

The following documents have been attached:

- Legal Description List of Adjacent Property Owners Preliminary Plat Preliminary Plan Impact Fee Form
Plat of Survey Site Plan Final Plat Final Plan Bank Trust Letter

Type of Action Requested

- Annexation Preliminary Plat/Plan (circle one) Conditional Use
Annexation Agreement Final Plat/Plan (circle one) Variance
Concept Plan Map Amendment from to Site Plan Review

I have submitted the required filing fee. I understand that the fee is non-refundable. The fee is determined according to the attached schedule of fees. 150.00 (initial here) 8 (fee)

Statement of Petition

Please provide a brief statement describing the proposal as it relates to the standards of petition accompanying this document (attach additional sheets if necessary).

The Variance request is for the the garage to be built in front of the home. The garage will be build on the South boundary property line in coordinates with the city building requirements. This will allow visibility of the home from the street.

Number of Dwelling Units 2 single family home with 2404 home
Proposed Time Schedule for Development 1 year for the home and attached Garage Type of Units attached and detached garage Square Footage 2400 Garage
Requested Variances 1-3 years detached garage to be built Would like Variance permanently attached to the property

Authorization

I hereby affirm that I have full legal capacity to authorize the filing of this petition and that all the information and exhibits herewith submitted are true and correct to the best of my knowledge.

State of County of Signature of Petitioner

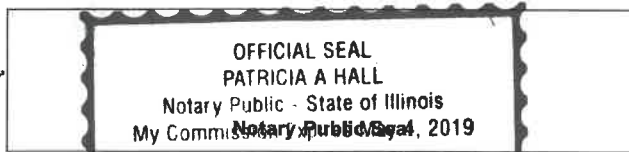

I, the undersigned, a notary public in and for the said county and state aforesaid, do hereby that Gene and Shari Skrocki is personally known to me to be the same person whose name is subscribed to the forgoing instrument, and that said person signed, sealed and delivered the above petition as a free and voluntary act, for the uses and purposes set forth.

Notary Signature: Patricia A Hall
My Commission Expires: May 4th 2019

Given under my hand and notary seal this 22nd day of May, A.D. 2018

14 55-557

RECORDED FEB. 10, 2006 AS DOC NO K 2006022711

FINAL PLAT OF KANKAKEE RIVER RIDGE SUBDIVISION

PART OF THE SOUTHEAST QUARTER OF SECTION 35, TOWNSHIP 33 NORTH, RANGE 9 EAST OF THE THIRD PRINCIPAL MERIDIAN, IN WILL COUNTY, ILLINOIS.

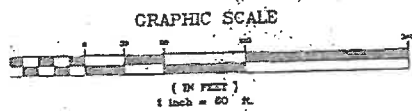

EASEMENT PROVISIONS

A PERPETUAL EASEMENT APPURTENANT IS HEREBY GRANTED TO THE CITY OF WILMINGTON, ILLINOIS...

An easement for serving the subdivision and other project with electric and communications service is hereby reserved...

An easement is hereby reserved for and granted to NORTHERN ILLINOIS GAS COMPANY, its successors and assigns...

LORIE W. PHILLIPS, 27th FEB 2006, Will County Recorder, Page 1 of 2

PC2 Date: 02/09/2006 Time: 14:23:32 Recording Fees: 31.00

DRAINAGE CERTIFICATE

STATE OF ILLINOIS, COUNTY OF WILL...

TO THE BEST OF MY KNOWLEDGE AND BELIEF, THE DRAINAGE OF SURFACE WATER SHALL NOT BE CHANGED BY THE CONSTRUCTION OF SUCH SUBDIVISION...

DATED THIS 27th DAY OF FEBRUARY, 2006

DAVID A. CLAASSEN, ILLINOIS PROFESSIONAL LAND SURVEYOR NO. 3902

SURVEYOR'S CERTIFICATE

STATE OF ILLINOIS, COUNTY OF WILL...

I HAVE SURVEYED THE FOLLOWING DESCRIBED PROPERTY: BEGINNING AT A POINT WHICH IS 833 FEET (RECORDED) 781 FEET (MEASURED) SOUTH OF A POINT IN THE NORTH LINE OF THE SOUTHEAST QUARTER OF SECTION 35...

ALL DIMENSIONS ARE GIVEN IN FEET AND DECIMAL PARTS THEREOF CORRECTED TO 82 DEGREES FAHRENHEIT. ALL LOT CORNERS HAVE BEEN STAKED WITH 5/8" x 30" REBAR, UNLESS OTHERWISE NOTED.

DAVID A. CLAASSEN, ILLINOIS PROFESSIONAL LAND SURVEYOR NO. 3902

ILLINOIS DEPARTMENT OF TRANSPORTATION

STATE OF ILLINOIS, COUNTY OF WILL... THIS PLAT HAS BEEN APPROVED BY THE ILLINOIS DEPARTMENT OF TRANSPORTATION WITH RESPECT TO ROADWAY ACCESS PURSUANT TO SECTION 2 OF AN ACT TO REVISE THE LAW IN RELATION TO PLATS...

DAVID M. O'KEEFE, P.E., DEPUTY DIRECTOR OF HIGHWAYS, RECORD ONE ENGINEER, DATE: 1-25-2006

ST. CORNER 35-33-9 DIA. PIPE

ENTRYS

HOLDER OF TITLE TO THE PROPERTY HEREIN DESCRIBED HAS CAUSED THE PROPERTY TO BE DIVIDED AS SHOWN ON THIS PLAT HEREON DRAWN...

NOTARY PUBLIC IN AND FOR THE COUNTY AND STATE AFORESAID, DO SOLEMNLY SWORE TO ME AND TO THE CONTENTS OF THE FOREGOING OWNERS STATEMENT...

"OFFICIAL SEAL" Notary Public, State of Illinois

MISSION/CITY COUNCIL

WILMINGTON CITY COUNCIL AT A MEETING HELD ON THE 20th DAY OF DECEMBER, A.D. 2005

BY WILLMINGTON PLAN COMMISSION THIS 14th DAY OF DECEMBER, A.D. 2005

PLATTING

DAVID A. CLAASSEN, DIRECTOR OF THE TAX MAPPING AND PLATTING DIVISION, ILLINOIS DO HEREBY CERTIFY THAT I HAVE REVIEWED THE PROPERTY DESCRIPTION OF AVAILABLE COUNTY RECORDS AND FIND SAID DESCRIPTION IS LOCATED ON...

COUNTY CLERK OF WILL COUNTY, ILLINOIS, DO HEREBY CERTIFY THAT THE PLAT AS SHOWN ON THIS PLAT HEREON DRAWN...

DEEDS

NUMBER A06-022971 HAS BEEN FILED FOR RECORDING ON THE OFFICE OF WILL COUNTY, ILLINOIS ON THE 10th DAY OF FEBRUARY, A.D. 2006...

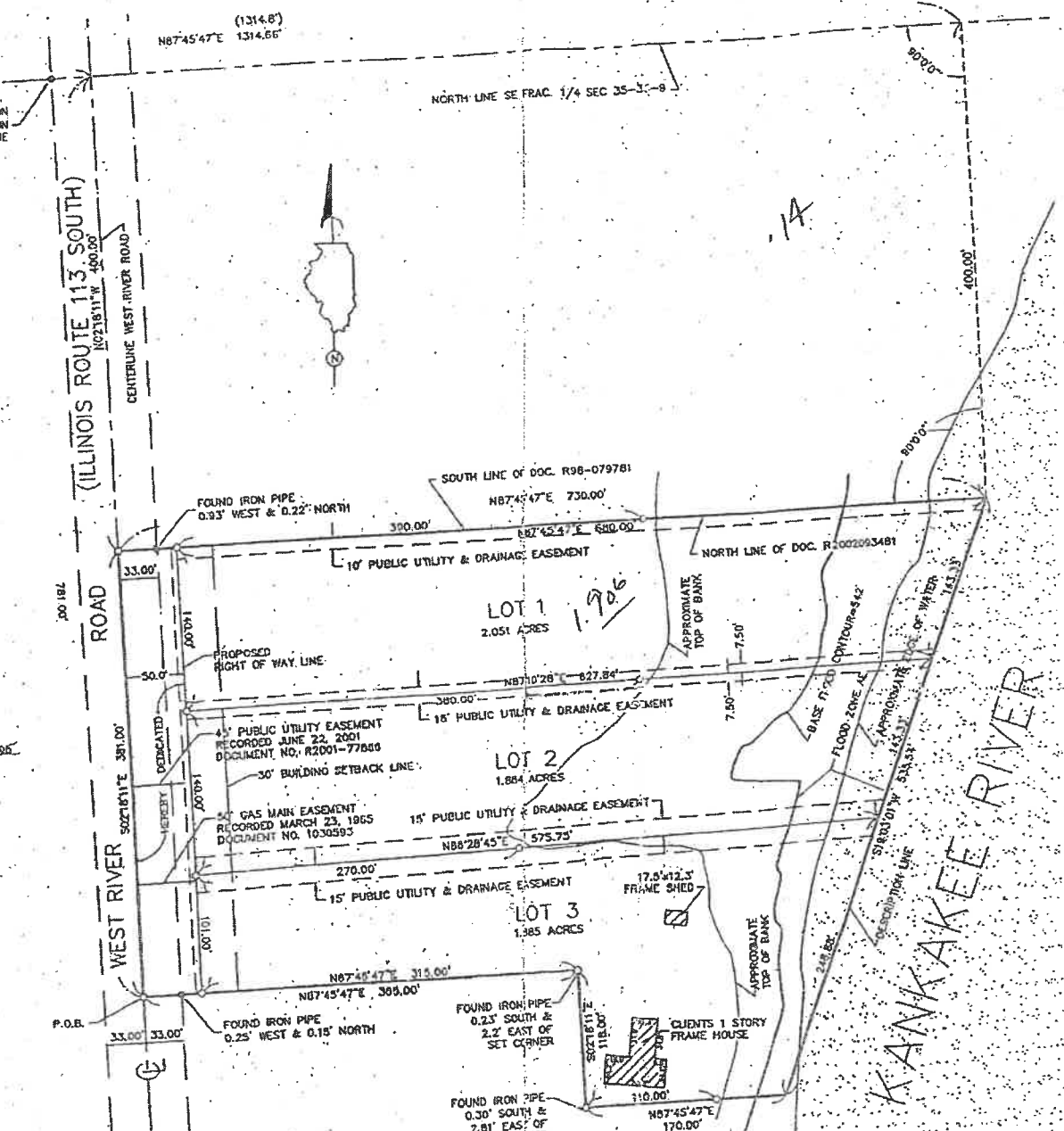

SCHOOL DISTRICT CERTIFICATE

STATE OF ILLINOIS, COUNTY OF WILL... THIS IS TO CERTIFY THAT I, DAVID A. CLAASSEN, AS OWNER OF THE PROPERTY DESCRIBED ON THIS PLAT AS THE SAME NAME HAVE DETERMINED TO THE BEST OF MY KNOWLEDGE...

DATED THE 07th DAY OF FEBRUARY, A.D. 2006

AS BENEFICIARY TO TRUST 1975 MUNICIPAL TRUST AND SAVINGS BANK

FOUND IRON REBAR PLACED RECORDED DATA MEASURED DIMENSION COMPUTED DIMENSION

BUILDING SETBACK LINES 30' FRONT, 10' SIDE, 20' REAR

REVISED 11/22/05 01/25/06 FINAL MYLAR

CLAASSEN, WHITE & ASSOCIATES P.C., SURVEYORS/ENGINEERS, 121 AIRPORT DRIVE, UNIT 1, JOLIET, ILLINOIS 60431

ORDERED BY: DAVID A. CLAASSEN

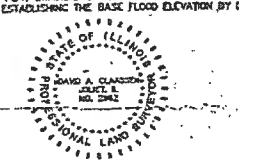

DD
THF
KS

A.D. 20

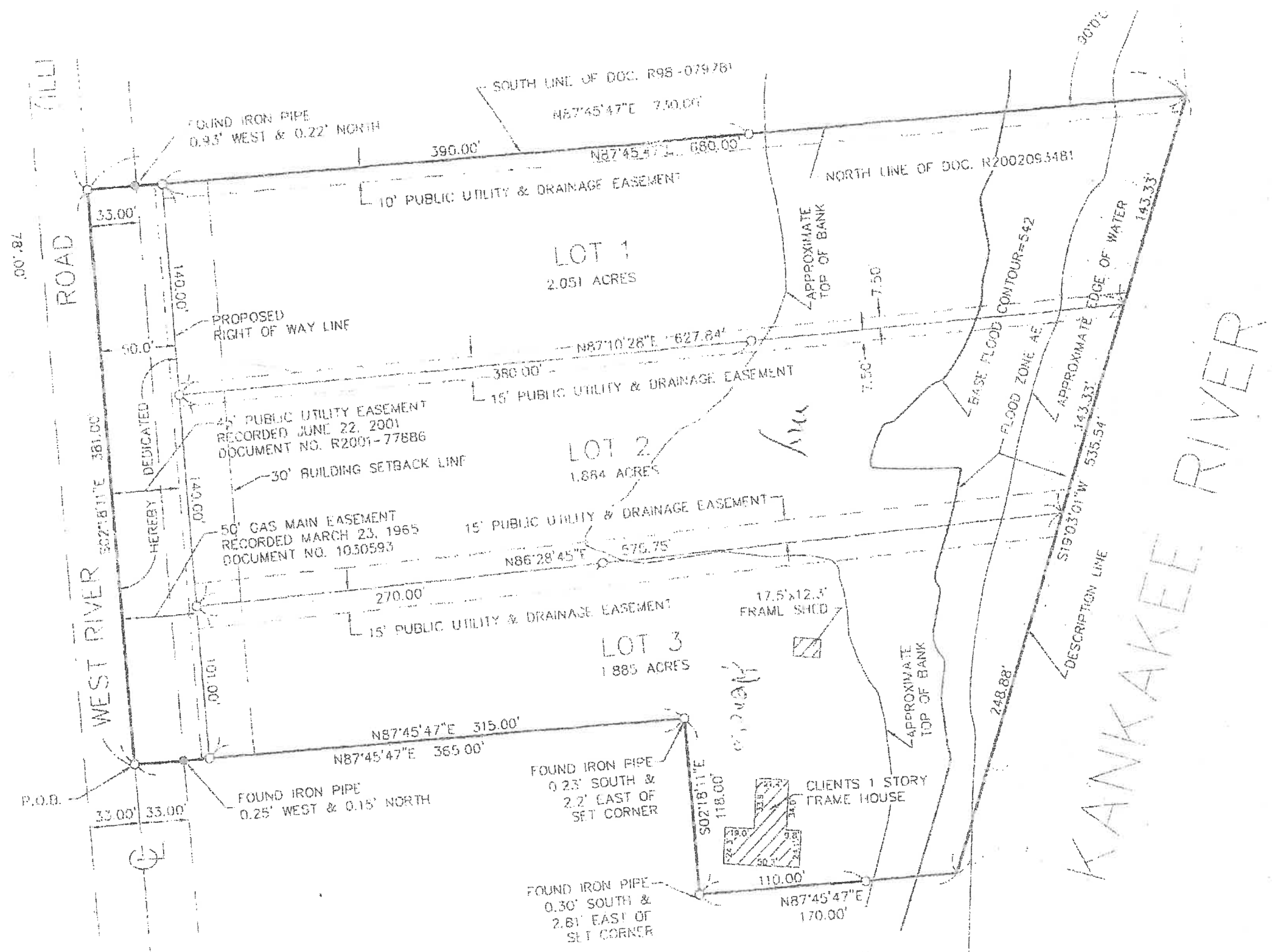

KANKAKEE RIVER

ILLINOIS DEPARTMENT OF TRANSPORTATION

SCHOOL DISTRICT CERTIFICATE

Memorandum

To: Wilmington Planning and Zoning Commission
From: Mike Dahm, AICP
Date: July 3, 2018
RE: Kankakee Ridge Lot 2- Variance

The Applicant, Gene and Shari Skrocki has submitted a petition for a variance to allow for an accessory structure to be built in front of the home proposed on Lot 2 in Kankakee River Ridge Subdivision (PIN 03-17-35-401-015-0000) located on West River Road.

Summary

The subject property is a 1.88 acre parcel of land located on the east side of W River Road approximately 1,160 feet south of Kerry Lane (See *Figure 1- Aerial*). A preliminary site plan has been submitted with the request that shows a 1 story house located near the bluff overlooking the river in the middle of the property with a 40' x 60' accessory structure near the south property line closer to W River Road than the house (See *Figure 3- Site Plan*).

Current Zoning

The property is zoned R1: Residential Single Family (See *Figure 2- Zoning*). Per zoning code 150.84 (A) *Location. Accessory structures may be built in a rear yard, but such structures or combination of structures shall not cover more than 30% of the required rear yard.* A request for a variance from 150.84 (A) has been submitted to allow for the accessory structure to be constructed in the front yard.

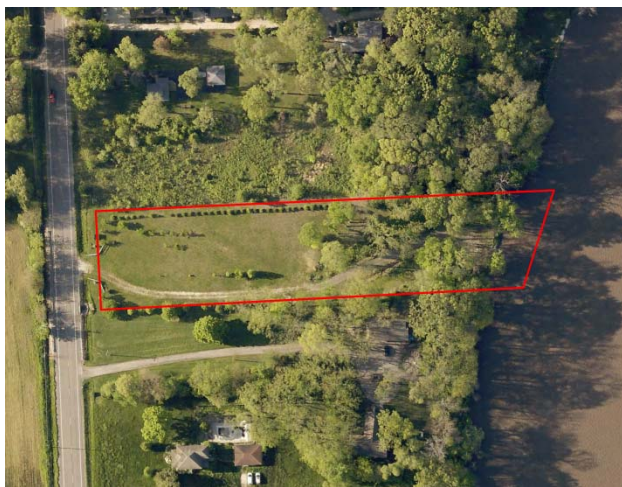

Figure 1- Aerial



Figure 2- Zoning



Plan Review and Analysis

Staff has reviewed the submitted request for a variance. The requested variance is for an accessory structure to be built within the front yard. The accessory structure will still be required to meet all other zoning requirements including side yard and front yard setback requirements. The site plan for this lot has a significant amount of grade variation that restricts the buildable area closer to the river to the north side of the property. The requested home location near the overlook of the river would limit access to an accessory structure and views to the river from the residence if it is built within the rear yard. This lot has unique circumstances that do not apply broadly to other lots within the City.

Recommended Actions

Staff is recommending that the Wilmington Planning and Zoning Commission approve the Variance to allow for an accessory structure to be built within the front yard. We would request that your recommendation of approval be made with the restriction that the facade of the accessory structure that will face West River Road be architecturally consistent in design and materials as the proposed house.

Recommended Motion

Motion to recommend approval to the City Council of the Variance to allow an accessory structure within the front yard subject to the following conditions:

- 1. The façade of the accessory structure facing West River Road shall be architecturally consistent with materials and design as the primary residence.*

City of Wilmington

Check Register Meeting Date: July 17, 2018



Check#	Date	Vendor/Employee	Amount
Fund	1	General Corporate Fund	
1746	7/17/2018	Friendly Farms, LTD	800.00
1747	7/17/2018	Michael Krebs	675.00
1748	7/17/2018	John Persic	316.36
1749	7/17/2018	Jim Brown	150.00
1750	7/17/2018	Coal Black Exotics	125.00
1751	7/17/2018	Bobby Hunt	400.00
1752	7/17/2018	Kankakee Shriners	500.00
1753	7/17/2018	Laser Encore	3,250.00
1754	7/17/2018	Void	-
1755	7/17/2018	Sean Oshea	450.00
1757	7/17/2018	Larry Roseland	450.00
1758	7/17/2018	Kathy Synoracki	550.00
1759	7/17/2018	Debbie Tennant	600.00
1760	7/17/2018	Rope Warrior Inc	300.00
1761	7/17/2018	James Orr Start Up	250.00
1762	7/17/2018	James Orr Petty Cash	500.00
0	7/17/2018	Payroll Sweep	77,237.79
0	7/17/2018	WEX Bank	3,315.88
0	7/17/2018	Paycor	434.29
0	7/17/2018	Misc Vendors - WPD	2,795.90
20155	7/17/2018	Advanced Public Safety, Inc.	856.80
20156	7/17/2018	Air Gas USA, LLC	58.80
20157	7/17/2018	Brown's Building Maintenance, Inc.	2,352.00
20158	7/17/2018	Jose Campos	53.35
20159	7/17/2018	Chicago Metropolitan Agency for Planning	213.86
20160	7/17/2018	Cintas Corporation	505.76
20161	7/17/2018	Cintas First Aid & Safety	172.06
20162	7/17/2018	Clark Baird Smith, LLC	502.50
20163	7/17/2018	ClearVoice, Inc.	190.00
20164	7/17/2018	Clennon Electric Co Inc	1,066.88
20165	7/17/2018	Comcast	149.85
20166	7/17/2018	Constellation New Energy, Inc	5,695.22
20167	7/17/2018	D'Orazio Ford	1,451.28
20168	7/17/2018	DTW Inc	5,266.79
20169	7/17/2018	Fisher Auto Parts Inc	107.47
20170	7/17/2018	G & D Tire Alignment	210.00
20171	7/17/2018	G W Communications	30.80
20172	7/17/2018	Grundy Supply	90.00
20173	7/17/2018	Helena Chemical Company	291.90

20174	7/17/2018	Illinois State Police	108.00
20175	7/17/2018	Intertrade Services Corp	2,295.91
20177	7/17/2018	Jcm Uniforms	741.16
20178	7/17/2018	Joliet Asphalt LLC	395.51
20179	7/17/2018	Karl Jurgens	11.15
20180	7/17/2018	Konica Minolta	261.90
20181	7/17/2018	Konica Minolta	285.86
20182	7/17/2018	Mack & Associates PC	17,900.00
20183	7/17/2018	McCann Industries Inc	519.78
20184	7/17/2018	William McCluskey	15.00
20186	7/17/2018	Municipal Code Corporation	275.00
20187	7/17/2018	Office Depot	87.48
20188	7/17/2018	Olivieri Brothers, Inc.	4,413.58
20189	7/17/2018	Patten Industries Inc	934.45
20190	7/17/2018	Planet Productions	7,500.00
20191	7/17/2018	Pomp's Tire Service, Inc.	1,561.43
20192	7/17/2018	Richard Quigley	9.50
20193	7/17/2018	Rendels, Inc.	78.50
20194	7/17/2018	Ruettiger Tonelli & Assoc	1,291.25
20195	7/17/2018	Sistek Sales Inc	392.54
20197	7/17/2018	Stanard & Associates, Inc.	1,290.00
20198	7/17/2018	TA Operating, LLC	821.16
20199	7/17/2018	Allegra Coal City, TGRV, LLC	120.79
20200	7/17/2018	TransUnionsRisk&Alternative Data Solutions, Inc.	50.00
20201	7/17/2018	Underground Pipe & Valve Co	704.00
20202	7/17/2018	Universal, Inc.	298.97
20203	7/17/2018	Waste Management Of Il SW	659.39
20204	7/17/2018	WESCOM	20,028.28
20205	7/17/2018	Will County Animal Control	250.00
20206	7/17/2018	Will County Recorder	75.50
TOTAL:			<u>175,741.63</u>

Fund	2	Water Operating M & R Fund	
0	7/17/2018	Payroll Sweep	19,837.79
0	7/17/2018	Misc Vendors	90.56
0	7/17/2018	WEX Bank	258.63
10411	7/17/2018	Accela, Inc. #774375	379.50
10414	7/17/2018	Comcast	104.85
10415	7/17/2018	DTW Inc	221.99
10416	7/17/2018	Dynegy Energy Services	3,651.44
10418	7/17/2018	Fisher Auto Parts Inc	26.86
10419	7/17/2018	G W Communications	830.00
10420	7/17/2018	Grainger	621.00
10423	7/17/2018	Jack Henry & Associates, Inc.	46.15
10424	7/17/2018	Konica Minolta	94.57
10428	7/17/2018	Nicor	162.64
10429	7/17/2018	PDC Labs Inc	821.50

10434	7/17/2018	USA Blue Book	124.29
10435	7/17/2018	Viking Chemical Company	4,872.98
10436	7/17/2018	Waste Management Of Il SW	37,810.90
10437	7/17/2018	Zenner Performance	900.00
TOTAL:			<u>70,855.65</u>

Fund	3	Sewer Capital Project Fund	
10433	7/17/2018	Strand Associates Inc	17,800.00
TOTAL:			<u>17,800.00</u>

Fund	4	Sewer Operating M & R Fund	
0	7/17/2018	Payroll Sweep	15,218.50
0	7/17/2018	Misc Vendors	90.56
0	7/17/2018	WEX Bank	199.37
10411	7/17/2018	Accela, Inc. #774375	379.50
10412	7/17/2018	Arro Laboratories Inc	25.00
10413	7/17/2018	Automatic Control Service	1,043.00
10415	7/17/2018	DTW Inc	150.00
10416	7/17/2018	Dynegy Energy Services	6,205.62
10417	7/17/2018	Evans Lawn & Garden Inc	41.69
10421	7/17/2018	Heritage FS, Inc.	474.40
10422	7/17/2018	Illinois Enviromental Protection Agency	15,000.00
10423	7/17/2018	Jack Henry & Associates, Inc.	46.15
10424	7/17/2018	Konica Minolta	94.57
10426	7/17/2018	Nestle Water North America	95.87
10427	7/17/2018	Nicor	97.56
10431	7/17/2018	Yatin M Shah MD SC	355.00
10432	7/17/2018	Steiner Electric Company	656.00
10434	7/17/2018	USA Blue Book	500.19
10436	7/17/2018	Waste Management Of Il SW	677.51
TOTAL:			<u>41,350.49</u>

Fund	5	DFC Federal Grant Fund	
0	7/12/2018	Better Business Planning Inc.	2,656.98
TOTAL:			<u>2,656.98</u>

Fund	7	ESDA Fund	
0	7/17/2018	WEX Bank	265.15
20176	7/17/2018	J.E. Weinel, Inc.	363.20
20185	7/17/2018	Menards Bradley	35.99
20196	7/17/2018	Southwest Mechanical Inc	476.90
20204	7/17/2018	WESCOM	2,244.92
TOTAL:			<u>3,386.16</u>

Fund	17	Water Capital Project Fund	
10425	7/17/2018	Midwest Meter Inc	1,653.50
10430	7/17/2018	Ruettiger Tonelli & Assoc	4,700.00

TOTAL: 6,353.50

Fund 24 Capital Project Fund
2055 7/17/2018 Ruettiger Tonelli & Assoc

TOTAL: 2,030.00
TOTAL: 2,030.00

Fund 25 RidgePort TIF#2 Fund
1132 7/17/2018 Foley & Lardner, LLP

TOTAL: 6,725.72
TOTAL: 6,725.72
GRAND TOTAL: 326,900.13

Dennis Vice

Floyd Combes

Steve Evans

John Persic, Jr.

Kevin Kirwin

Frank Studer

Lisa Butler

Fran Tutor

Approved: July 17, 2018

City of Wilmington
Collector's Report of Deposits Other Than Taxes
For the Month Ended June 30, 2018

GENERAL CORPORATE

BUSINESS REGISTRATION FEE	40
ECONOMIC DEVELOPMENT FEE	613
CONTRACTOR'S REGISTRATION FEE	-
OPERATING LICENSES - MISC	5,160
LIQUOR LICENSES	340
OTHER MISC. REIMBURSEMENTS	530
HEALTH INSURANCE REIMBURSEMENTS	4,827
OTHER MISC. INCOME	7,523
DEVELOPERS REIMBURSEMENTS	42,908

BUILDING

BUILDING PERMIT FEES	22,550
BUILDING PERMIT INSPECTION FEES	17,750
PLANNING & ZONING FEE	1,639

POLICE

CLERK OF CIRCUIT COURT FINES	7,197
ORDINANCE/MISC FINES	5,200
IMPOUNDMENT FINES	-
K-9 DONATIONS	-

GENERAL CORPORATE TOTAL	116,278
-------------------------	---------

WATER & SEWER

WATER DIST SYSTEM TAP-ON FEES	2,000
WATER SYSTEM CAPACITY USER FEES	4,400
WATER METER PURCHASES	2,650
SEWER SYSTEM CAPACITY USER FEES	15,750
SEWER COLLECTION SYSTEM FEES	6,000
LATE FEES/PENALTIES	6,686
OTHER MISC. INCOME	29,966
OTHER REIMBURSEMENTS - W&S	2,536
UTILITY BILLING CASH RECEIPTS	296,523

WATER & SEWER TOTAL	366,511
---------------------	---------

<u>TOTAL MONTHLY RECEIPTS:</u>	482,789
---------------------------------------	----------------

<u>Fund</u>	<u>Description</u>	<u>YTD Balance Before Period</u>	<u>Revenues for Period</u>	<u>Expenses for Period</u>	<u>Year to Date Amount</u>
01	General Corporate Fund	91,605.79	806,072.77	482,204.64	415,473.92
02	Water Operating M & R Fund	37,331.45	144,850.76	98,388.63	83,793.58
03	Sewer Capital Project Fund	70,670.71	124,132.93	0.00	194,803.64
04	Sewer Operating M & R Fund	(420,207.89)	100,877.79	68,668.95	(387,999.05)
05	DFC Federal Grant Fund	(0.00)	11,172.11	11,172.11	0.00
06	Motor Fuel Tax Fund	13,643.39	12,635.19	0.00	26,278.58
07	ESDA Fund	(6,824.27)	1,294.38	5,605.13	(11,135.02)
12	Debt Service Fund	12,214.21	65,640.85	0.00	77,855.06
17	Water Capital Project Fund	27,097.99	35,504.41	23,472.13	39,130.27
20	Building Deposit Holding Acct	0.00	0.00	0.00	0.00
21	Mobile Equipment Fund	0.00	620.00	0.00	620.00
24	Capital Project Fund	121,582.02	472.97	66,022.37	56,032.62
25	RidgePort TIF#2 Fund	459,181.43	1,863,882.35	9,035.50	2,314,028.28
Report Totals:		406,294.83	3,167,156.51	764,569.46	2,808,881.88

General Ledger
Revenue vs. Expenditure By Fund

Account	Description	Budget	Period Amount	Year to Date Amount	Year to Date Variance	Percent Variance
01	General Corporate Fund					
	Property Tax Revenue	1,181,956.00	505,027.71	621,490.26	560,465.74	47.41
	Taxes-State Per Capita Revenue	701,000.00	49,807.57	139,525.39	561,474.61	80.09
	Tax Revenue - Other	1,123,800.00	94,253.60	196,229.45	927,570.55	82.53
	Utility Taxes	515,000.00	39,806.22	88,327.75	426,672.25	82.84
	License Fees	88,000.00	6,183.13	14,641.26	73,358.74	83.36
	Building Fees	574,000.00	41,939.40	43,984.40	530,015.60	92.33
	Franchise Fee	78,000.00	0.00	18,908.02	59,091.98	75.75
	Fines and Court Fees	135,000.00	12,397.46	26,523.53	108,476.47	80.35
	Revenue from Bonds/Loans	300,000.00	0.00	0.00	300,000.00	100.00
	Rental Income	500.00	0.00	75.00	425.00	85.00
	Interest Income	8,000.00	1,035.42	1,819.57	6,180.43	77.25
	Grants - Misc.	14,960.00	0.00	0.00	14,960.00	100.00
	Special Use Revenue	3,000.00	0.00	0.00	3,000.00	100.00
	Developer Reimbursements	506,500.00	42,907.96	87,818.58	418,681.42	82.66
	Other Reimbursements	25,000.00	500.00	500.00	24,500.00	98.00
	Employee Ins Reimb.	57,000.00	4,827.04	9,991.37	47,008.63	82.47
	Other Misc. Income	92,000.00	7,387.26	13,178.23	78,821.77	85.67
	Transfers From Other Funds	0.00	0.00	0.00	0.00	0.00
	REVENUE Totals:	5,403,716.00	806,072.77	1,263,012.81	4,140,703.19	76.62
	Salary Expense	2,052,500.00	142,790.24	291,053.84	1,761,446.16	85.82
	Police Commission Exp	16,000.00	0.00	154.88	15,845.12	99.03
	Employee Health & Life Insuran	348,000.00	24,549.82	46,953.69	301,046.31	86.50
	Retired Empl Health Ins/Dental	120,000.00	10,614.62	17,194.13	102,805.87	85.67
	Oper Supplies and Tools	40,000.00	695.83	2,143.73	37,856.27	94.64
	Gasoline, Oil & Tolls	61,000.00	4,987.21	9,284.15	51,715.85	84.78
	Office Supplies	14,900.00	139.75	193.07	14,706.93	98.70
	Training Expenses & Mileage	25,000.00	2,826.34	4,385.89	20,614.11	82.45
	Property, Equip & Liability Ins	335,000.00	11,030.00	11,030.00	323,970.00	96.70
	Engineering Services	5,000.00	0.00	0.00	5,000.00	100.00
	Legal Services	102,000.00	5,956.00	6,556.00	95,444.00	93.57
	Notices/Legal Publications	5,800.00	30.80	222.80	5,577.20	96.15
	Consulting/Service Fees	415,500.00	1,923.27	8,397.86	407,102.14	97.97
	Other Professional Services	334,400.00	20,370.52	56,755.36	277,644.64	83.02
	Computer Maint. & Prog. Fees	49,200.00	1,834.73	9,382.76	39,817.24	80.92
	Dues, Subscrip. & Memberships	12,300.00	0.00	196.00	12,104.00	98.40
	Community Dev Expense	71,000.00	4,820.67	4,820.67	66,179.33	93.21
	Maintenance - Equipment	46,500.00	1,185.18	1,735.60	44,764.40	96.26
	Maintenance - Grounds/Building	153,000.00	28,066.26	32,273.83	120,726.17	78.90
	Vehicle Expenses	45,000.00	253.75	672.98	44,327.02	98.50
	Uniforms	30,000.00	3,668.35	10,074.13	19,925.87	66.42
	Rental of Equipment	8,500.00	230.00	230.00	8,270.00	97.29
	Utilities / Telephone Services	139,100.00	10,526.30	19,021.16	120,078.84	86.32
	Misc	158,000.00	25.00	25.00	157,975.00	99.98

<u>Account</u>	<u>Description</u>	<u>Budget</u>	<u>Period Amount</u>	<u>Year to Date Amount</u>	<u>Year to Date Variance</u>	<u>Percent Variance</u>
	Expensed Equipment	24,242.00	3,724.29	9,555.29	14,686.71	60.58
	Leased Equipment	90,910.00	3,441.59	50,103.67	40,806.33	44.88
	Capital Equipment Purchases	406,000.00	8,080.00	8,080.00	397,920.00	98.01
	Transfers to Other Funds	132,000.00	0.00	0.00	132,000.00	100.00
	K-9 Program	7,000.00	0.00	273.65	6,726.35	96.09
	Payroll Tax/Pension Expenses	664,500.00	190,434.12	246,768.75	417,731.25	62.86
	EXPENSES Totals:	5,912,352.00	482,204.64	847,538.89	5,064,813.11	85.66
01	Totals:	(508,636.00)*	323,868.13*	415,473.92*	(924,109.92)*	181.68*
02	Water Operating M & R Fund					
	Garbage Collection Fees	470,000.00	38,113.80	75,990.87	394,009.13	83.83
	Utility Usage Fees	1,005,000.00	98,254.65	181,023.74	823,976.26	81.98
	Utility Base/DS Fees	0.00	0.00	0.00	0.00	0.00
	Meter Fees	16,000.00	2,650.00	3,999.00	12,001.00	75.00
	Utility Capacity Fees	30,000.00	4,400.00	4,400.00	25,600.00	85.33
	Interest Income	1,200.00	257.07	487.00	713.00	59.41
	Other Reimbursements	13,000.00	618.49	1,984.85	11,015.15	84.73
	Other Misc. Income	4,000.00	556.75	956.75	3,043.25	76.08
	Transfers From Other Funds	100,000.00	0.00	0.00	100,000.00	100.00
	REVENUE Totals:	1,639,200.00	144,850.76	268,842.21	1,370,357.79	83.59
	Salary Expense	421,503.00	24,861.10	52,560.31	368,942.69	87.53
	Employee Health & Life Insuran	98,000.00	5,183.79	10,278.89	87,721.11	89.51
	Oper Supplies and Tools	12,000.00	1,527.48	1,564.47	10,435.53	86.96
	Gasoline, Oil & Tolls	10,000.00	359.63	645.33	9,354.67	93.54
	Office Supplies	11,700.00	501.02	1,592.18	10,107.82	86.39
	Training Expenses & Mileage	4,000.00	0.00	0.00	4,000.00	100.00
	Property, Equip & Liability Ins	114,000.00	1,939.00	1,939.00	112,061.00	98.29
	Legal Services	5,000.00	0.00	0.00	5,000.00	100.00
	Notices/Legal Publications	1,500.00	72.00	72.00	1,428.00	95.20
	Consulting /Service Fees	8,500.00	661.48	1,340.88	7,159.12	84.22
	Other Professional Services	17,000.00	617.75	1,630.75	15,369.25	90.40
	Computer Maint. & Prog. Fees	14,500.00	435.65	3,947.65	10,552.35	72.77
	Dues, Subscrp. & Memberships	800.00	0.00	0.00	800.00	100.00
	Maintenance - Equipment	56,500.00	7,340.88	7,582.88	48,917.12	86.57
	Maintenance - Grounds/Building	29,500.00	390.87	390.87	29,109.13	98.67
	Vehicle Expenses	2,500.00	0.00	0.00	2,500.00	100.00
	Uniforms	2,000.00	0.00	0.00	2,000.00	100.00
	Rental of Equipment	13,000.00	0.00	0.00	13,000.00	100.00
	Utilities / Telephone Services	82,500.00	4,954.21	5,059.06	77,440.94	93.86
	Debt Service Bond Pymts	69,700.00	0.00	0.00	69,700.00	100.00
	Misc	22,500.00	0.00	0.00	22,500.00	100.00
	Expensed Equipment	1,000.00	0.00	0.00	1,000.00	100.00

Account	Description	Budget	Period Amount	Year to Date Amount	Year to Date Variance	Percent Variance
	Leased Equipment	29,000.00	94.57	189.14	28,810.86	99.34
	Capital Equipment Purchases	8,000.00	0.00	0.00	8,000.00	100.00
	Transfers to Other Funds	0.00	0.00	0.00	0.00	0.00
	Chemical Treatment, Disposal	145,000.00	7,344.04	12,106.44	132,893.56	91.65
	Garbage Disposal Fee	470,000.00	37,831.79	74,649.42	395,350.58	84.11
	Payroll Tax/Pension Expenses	79,500.00	4,273.37	9,499.36	70,000.64	88.05
	EXPENSES Totals:	1,729,203.00	98,388.63	185,048.63	1,544,154.37	89.29
02	Totals:	(90,003.00)*	46,462.13*	83,793.58*	(173,796.58)*	193.10*
03	Sewer Capital Project Fund					
	Utility Usage Fees	43,000.00	3,469.52	6,860.88	36,139.12	84.04
	Utility Base/DS Fees	1,013,000.00	86,100.39	171,676.57	841,323.43	83.05
	Utility Capacity Fees	0.00	0.00	0.00	0.00	0.00
	Utility Exp. Fees (TAP)	12,000.00	6,000.00	6,000.00	6,000.00	50.00
	Revenue from Bonds/Loans	1,000,000.00	0.00	0.00	1,000,000.00	100.00
	Rental Income	6,600.00	550.00	1,100.00	5,500.00	83.33
	Interest Income	7,000.00	1,316.02	2,638.07	4,361.93	62.31
	Other Reimbursements	0.00	0.00	0.00	0.00	0.00
	Other Misc. Income	24,000.00	26,697.00	26,697.00	(2,697.00)	(11.23)
	Transfers From Other Funds	100,000.00	0.00	0.00	100,000.00	100.00
	REVENUE Totals:	2,205,600.00	124,132.93	214,972.52	1,990,627.48	90.25
	Salary Expense	2,000.00	0.00	2,000.00	0.00	0.00
	Engineering Services	30,000.00	0.00	0.00	30,000.00	100.00
	Legal Services	5,000.00	0.00	0.00	5,000.00	100.00
	Other Professional Services	2,000.00	0.00	0.00	2,000.00	100.00
	Misc	20,000.00	0.00	0.00	20,000.00	100.00
	Other Capital Projects	1,034,000.00	0.00	0.00	1,034,000.00	100.00
	Capital Equipment Purchases	25,500.00	0.00	16,000.00	9,500.00	37.25
	Construction Projects	50,000.00	0.00	2,168.88	47,831.12	95.66
	Transfers to Other Funds	903,000.00	0.00	0.00	903,000.00	100.00
	EXPENSES Totals:	2,071,500.00	0.00	20,168.88	2,051,331.12	99.02
03	Totals:	134,100.00*	124,132.93*	194,803.64*	(60,703.64)*	(45.26)*
04	Sewer Operating M & R Fund					
	Utility Usage Fees	900,000.00	84,259.87	160,420.37	739,579.63	82.17
	Utility Base/DS Fees	0.00	0.00	(0.00)	0.00	0.00
	Utility Capacity Fees	100,000.00	15,750.00	15,750.00	84,250.00	84.25
	Interest Income	0.00	0.00	0.00	0.00	0.00
	Other Reimbursements	16,000.00	817.92	1,906.41	14,093.59	88.08
	Other Misc. Income	0.00	50.00	100.00	(100.00)	0.00
	Transfers From Other Funds	903,000.00	0.00	0.00	903,000.00	100.00

General Ledger
Revenue vs. Expenditure By Fund

Account	Description	Budget	Period Amount	Year to Date Amount	Year to Date Variance	Percent Variance
	REVENUE Totals:	1,919,000.00	100,877.79	178,176.78	1,740,823.22	90.71
	Salary Expense	356,000.00	22,967.01	47,887.91	308,112.09	86.54
	Employee Health & Life Insuran	90,000.00	6,993.81	13,629.63	76,370.37	84.85
	Oper Supplies and Tools	17,000.00	1,108.84	1,487.88	15,512.12	91.24
	Gasoline, Oil & Tolls	6,000.00	1,644.11	1,757.06	4,242.94	70.71
	Office Supplies	14,500.00	691.72	2,255.87	12,244.13	84.44
	Training Expenses & Mileage	12,500.00	0.00	75.45	12,424.55	99.39
	Property, Equip & Liability Ins	99,000.00	1,520.00	1,520.00	97,480.00	98.46
	Engineering Services	5,000.00	0.00	0.00	5,000.00	100.00
	Legal Services	5,000.00	0.00	0.00	5,000.00	100.00
	Notices/Legal Publications	800.00	72.00	264.00	536.00	67.00
	Consulting /Service Fees	9,000.00	661.48	1,340.89	7,659.11	85.10
	Other Professional Services	30,000.00	420.00	420.00	29,580.00	98.60
	Computer Maint. & Prog. Fees	16,000.00	435.65	3,947.65	12,052.35	75.32
	Dues, Subscrip. & Memberships	1,200.00	538.60	538.60	661.40	55.11
	Maintenance - Equipment	58,500.00	1,267.34	3,926.35	54,573.65	93.28
	Maintenance - Grounds/Building	53,500.00	15,948.66	15,948.66	37,551.34	70.18
	Vehicle Expenses	8,500.00	0.00	0.00	8,500.00	100.00
	Uniforms	3,500.00	0.00	0.00	3,500.00	100.00
	Rental of Equipment	8,000.00	0.00	0.00	8,000.00	100.00
	Utilities / Telephone Services	111,500.00	7,317.32	7,442.30	104,057.70	93.32
	Debt Service Bond Pymts	903,000.00	0.00	451,056.86	451,943.14	50.04
	Misc	21,000.00	0.00	119.50	20,880.50	99.43
	Expensed Equipment	1,000.00	0.00	0.00	1,000.00	100.00
	Leased Equipment	3,000.00	94.57	189.14	2,810.86	93.69
	Capital Equipment Purchases	10,000.00	0.00	0.00	10,000.00	100.00
	Transfers to Other Funds	100,000.00	0.00	0.00	100,000.00	100.00
	Chemical Treatment, Disposal	95,000.00	3,070.67	4,009.87	90,990.13	95.77
	Payroll Tax/Pension Expenses	70,000.00	3,917.17	8,358.21	61,641.79	88.06
	EXPENSES Totals:	2,108,500.00	68,668.95	566,175.83	1,542,324.17	73.14
	04 Totals:	(189,500.00)*	32,208.84*	(387,999.05)*	198,499.05*	(104.74)*
05	DFC Federal Grant Fund					
	Grants - Federal	185,000.00	11,172.11	29,937.70	155,062.30	83.81
	REVENUE Totals:	185,000.00	11,172.11	29,937.70	155,062.30	83.81
	Misc	185,000.00	11,172.11	29,937.70	155,062.30	83.81
	EXPENSES Totals:	185,000.00	11,172.11	29,937.70	155,062.30	83.81
	05 Totals:	0.00*	(0.00)*	0.00*	(0.00)*	0.00*
06	Motor Fuel Tax Fund					

General Ledger
Revenue vs. Expenditure By Fund

Account	Description	Budget	Period Amount	Year to Date Amount	Year to Date Variance	Percent Variance
	Taxes-State Per Capita Revenue	147,000.00	12,063.57	25,167.33	121,832.67	82.87
	Interest Income	1,500.00	571.62	1,111.25	388.75	25.91
	Other Misc. Income	5,000.00	0.00	0.00	5,000.00	100.00
	REVENUE Totals:	153,500.00	12,635.19	26,278.58	127,221.42	82.88
	Misc	5,000.00	0.00	0.00	5,000.00	100.00
	Road Construction Projects	10,000.00	0.00	0.00	10,000.00	100.00
	Road Repair Materials	329,000.00	0.00	0.00	329,000.00	100.00
	EXPENSES Totals:	344,000.00	0.00	0.00	344,000.00	100.00
06	Totals:	(190,500.00)*	12,635.19*	26,278.58*	(216,778.58)*	113.79*
07	ESDA Fund					
	Property Tax Revenue	3,000.00	1,294.38	1,589.11	1,410.89	47.03
	Interest Income	0.00	0.00	0.00	0.00	0.00
	Grants - State- Other	6,000.00	0.00	0.00	6,000.00	100.00
	Special Use Revenue	0.00	0.00	0.00	0.00	0.00
	Other Reimbursements	500.00	0.00	84.89	415.11	83.02
	Other Misc. Income	5,000.00	0.00	0.00	5,000.00	100.00
	Transfers From Other Funds	50,000.00	0.00	0.00	50,000.00	100.00
	REVENUE Totals:	64,500.00	1,294.38	1,674.00	62,826.00	97.40
	Salary Expense	9,000.00	0.00	2,250.00	6,750.00	75.00
	Oper Supplies and Tools	12,000.00	1,068.46	1,097.15	10,902.85	90.85
	Gasoline, Oil & Tolls	4,000.00	275.52	626.93	3,373.07	84.32
	Office Supplies	950.00	560.93	560.93	389.07	40.95
	Training Expenses & Mileage	4,000.00	0.00	0.00	4,000.00	100.00
	Notices/Legal Publications	200.00	0.00	0.00	200.00	100.00
	Other Professional Services	6,500.00	34.20	102.60	6,397.40	98.42
	Dues, Subscrip. & Memberships	700.00	0.00	83.95	616.05	88.00
	Maintenance - Equipment	6,500.00	736.41	736.41	5,763.59	88.67
	Vehicle Expenses	4,000.00	0.00	0.00	4,000.00	100.00
	Utilities / Telephone Services	11,500.00	1,104.60	1,876.02	9,623.98	83.68
	Misc	6,500.00	0.00	0.00	6,500.00	100.00
	Expensed Equipment	1,500.00	0.00	0.00	1,500.00	100.00
	Leased Equipment	23,000.00	1,825.01	5,475.03	17,524.97	76.19
	Capital Equipment Purchases	6,000.00	0.00	0.00	6,000.00	100.00
	Transfers to Other Funds	5,000.00	0.00	0.00	5,000.00	100.00
	EXPENSES Totals:	101,350.00	5,605.13	12,809.02	88,540.98	87.36
07	Totals:	(36,850.00)*	(4,310.75)*	(11,135.02)*	(25,714.98)*	69.78*
12	Debt Service Fund					
	Property Tax Revenue	146,067.00	62,746.86	77,034.35	69,032.65	47.26

Account	Description	Budget	Period Amount	Year to Date Amount	Year to Date Variance	Percent Variance
	Deer Ridge SSA Repayments	33,000.00	2,618.55	5,237.10	27,762.90	84.13
	Revenue from Bonds/Loans	140,000.00	0.00	0.00	140,000.00	100.00
	Interest Income	1,500.00	275.44	489.86	1,010.14	67.34
	Other Misc. Income	0.00	0.00	0.00	0.00	0.00
	Transfers From Other Funds	6,800.00	0.00	0.00	6,800.00	100.00
	REVENUE Totals:	327,367.00	65,640.85	82,761.31	244,605.69	74.71
	Consulting /Service Fees	6,000.00	0.00	0.00	6,000.00	100.00
	Debt Service Bond Pymts	312,000.00	0.00	4,906.25	307,093.75	98.42
	Misc	6,000.00	0.00	0.00	6,000.00	100.00
	Transfers to Other Funds	10,000.00	0.00	0.00	10,000.00	100.00
	EXPENSES Totals:	334,000.00	0.00	4,906.25	329,093.75	98.53
	12 Totals:	(6,633.00)*	65,640.85*	77,855.06*	(84,488.06)*	1,273.75*
17	Water Capital Project Fund					
	Utility Usage Fees	37,000.00	3,216.36	6,232.27	30,767.73	83.15
	Utility Base/DS Fees	260,000.00	22,212.95	44,283.20	215,716.80	82.96
	Meter Replacement Fees	76,500.00	6,436.37	12,837.37	63,662.63	83.21
	Utility Capacity Fees	0.00	0.00	0.00	0.00	0.00
	Utility Exp. Fees (TAP)	4,000.00	2,000.00	2,000.00	2,000.00	50.00
	Revenue from Bonds/Loans	300,000.00	0.00	0.00	300,000.00	100.00
	Rental Income	6,600.00	550.00	1,100.00	5,500.00	83.33
	Interest Income	5,000.00	1,088.73	2,149.56	2,850.44	57.00
	Other Reimbursements	0.00	0.00	0.00	0.00	0.00
	Other Misc. Income	0.00	0.00	0.00	0.00	0.00
	Transfers From Other Funds	0.00	0.00	0.00	0.00	0.00
	REVENUE Totals:	689,100.00	35,504.41	68,602.40	620,497.60	90.04
	Salary Expense	6,000.00	0.00	6,000.00	0.00	0.00
	Legal Services	5,000.00	0.00	0.00	5,000.00	100.00
	Consulting /Service Fees	35,000.00	10,750.00	10,750.00	24,250.00	69.28
	Other Professional Services	0.00	0.00	0.00	0.00	0.00
	Maintenance - Equipment	110,000.00	12,722.13	12,722.13	97,277.87	88.43
	Misc	10,000.00	0.00	0.00	10,000.00	100.00
	Other Capital Projects	408,000.00	0.00	0.00	408,000.00	100.00
	Capital Equipment Purchases	22,000.00	0.00	0.00	22,000.00	100.00
	Transfers to Other Funds	100,000.00	0.00	0.00	100,000.00	100.00
	EXPENSES Totals:	696,000.00	23,472.13	29,472.13	666,527.87	95.76
	17 Totals:	(6,900.00)*	12,032.28*	39,130.27*	(46,030.27)*	667.10*
20	Building Deposit Holding Acct					
	Interest Income	0.00	0.00	0.00	0.00	0.00

General Ledger
Revenue vs. Expenditure By Fund

Account	Description	Budget	Period Amount	Year to Date Amount	Year to Date Variance	Percent Variance
	Other Misc. Income	0.00	0.00	0.00	0.00	0.00
	Transfers From Other Funds	0.00	0.00	0.00	0.00	0.00
	REVENUE Totals:	0.00	0.00	0.00	0.00	0.00
	Community Dev Expense	15,000.00	0.00	0.00	15,000.00	100.00
	Misc	1,000.00	0.00	0.00	1,000.00	100.00
	Transfers to Other Funds	15,000.00	0.00	0.00	15,000.00	100.00
	EXPENSES Totals:	31,000.00	0.00	0.00	31,000.00	100.00
20	Totals:	(31,000.00)*	0.00*	0.00*	(31,000.00)*	100.00*
21	Mobile Equipment Fund					
	Fines and Court Fees	15,000.00	620.00	620.00	14,380.00	95.86
	Transfers From Other Funds	20,000.00	0.00	0.00	20,000.00	100.00
	REVENUE Totals:	35,000.00	620.00	620.00	34,380.00	98.22
	MEF FUND Purchases	0.00	0.00	0.00	0.00	0.00
	Transfers to Other Funds	0.00	0.00	0.00	0.00	0.00
	EXPENSES Totals:	0.00	0.00	0.00	0.00	0.00
21	Totals:	35,000.00*	620.00*	620.00*	34,380.00*	98.22*
24	Capital Project Fund					
	Revenue from Bonds/Loans	10,000.00	0.00	0.00	10,000.00	100.00
	Interest Income	3,000.00	472.97	898.05	2,101.95	70.06
	Grants- State IDOT/EDP	3,824,000.00	0.00	121,156.94	3,702,843.06	96.83
	Grants - State- Other	52,000.00	0.00	0.00	52,000.00	100.00
	Grants - Misc.	101,500.00	0.00	0.00	101,500.00	100.00
	Developer Reimbursements	301,000.00	0.00	0.00	301,000.00	100.00
	Other Reimbursements	331,000.00	0.00	0.00	331,000.00	100.00
	Other Misc. Income	60,000.00	0.00	0.00	60,000.00	100.00
	Transfers From Other Funds	50,000.00	0.00	0.00	50,000.00	100.00
	REVENUE Totals:	4,732,500.00	472.97	122,054.99	4,610,445.01	97.42
	Consulting /Service Fees	500.00	0.00	0.00	500.00	100.00
	Other Professional Services	50,000.00	0.00	0.00	50,000.00	100.00
	Misc	10,000.00	0.00	0.00	10,000.00	100.00
	Other Capital Projects	391,000.00	0.00	0.00	391,000.00	100.00
	Transfers to Other Funds	0.00	0.00	0.00	0.00	0.00
	Road Construction Projects	4,430,000.00	66,022.37	66,022.37	4,363,977.63	98.51
	Bridge Cap Projects	73,000.00	0.00	0.00	73,000.00	100.00
	EXPENSES Totals:	4,954,500.00	66,022.37	66,022.37	4,888,477.63	98.66

Account	Description	Budget	Period Amount	Year to Date Amount	Year to Date Variance	Percent Variance
24 Totals:		(222,000.00)*	(65,549.40)*	56,032.62*	(278,032.62)*	125.24*
25	RidgePort TIP#2 Fund					
	Property Tax Revenue	4,910,000.00	1,862,563.69	2,321,580.03	2,588,419.97	52.71
	Interest Income	15,000.00	1,318.66	1,483.75	13,516.25	90.10
	REVENUE Totals:	4,925,000.00	1,863,882.35	2,323,063.78	2,601,936.22	52.83
	Other Professional Services	50,000.00	9,035.50	9,035.50	40,964.50	81.92
	Community Dev Expense	4,890,000.00	0.00	0.00	4,890,000.00	100.00
	EXPENSES Totals:	4,940,000.00	9,035.50	9,035.50	4,930,964.50	99.81
25 Totals:		(15,000.00)*	1,854,846.85*	2,314,028.28*	(2,329,028.28)*	15,526.85*
	REVENUE TOTAL	22,279,483.00**	3,167,156.51**	4,579,997.08**		
	EXPENSE TOTAL	23,407,405.00**	764,569.46**	1,771,115.20**		
	GRAND TOTAL	(1,127,922.00)**	2,402,587.05**	2,808,881.88**		

Latinos Landscaping

**P.O. Box 283
Joliet, IL 60432**

Estimate

Date	Estimate #
7/9/2018	269

Name / Address
City of Wilmington 1165 South Water Street Wilmington, IL. 60481

Job Site

Description	Total
We propose to provide equipment, labor and material to do the following work	
1.) Clean up all loose gravel, dirt and grown weeds in the cracks in the parking lot.	
2.) Crack fill \$1.35 per linear foot.	
3.) Seal coating with water base	6,136.00
4.) Striping	865.00

We look forward to doing business with you.

Proposal may be withdrawn if not signed with in 30 days

Signature _____

ESTIMATE

Wilmington City Hall
(815) 476-2175



Low Cost Sealcoating

Braceville, IL 60407

Phone: (815) 342-5759

Email: lathamtim20@yahoo.com

Estimate #

005846

Date

07/09/2018

Description

Total

Low Cost Sealcoating

\$7,875.00

Clean parking lot, apply hot rubber crack filler, apply sealer and stripe front and back parking area located at 1165 S Water St, Wilmington, IL 60481.

Subtotal

\$7,875.00

Total

\$7,875.00

Notes:

There is a deposit required of 2800.00 upon start date.

Tim Latham

Wilmington City Hall

J. LUCAS AND SONS PAVING, INC.
805 RICHARDS STREET
JOLIET, IL. 60433
PH: (815) 726-0034
FAX: (815) 726-7109

JULY 6, 2018

PREVAILING WAGE

JOB SITE: SAME

CITY OF WILMINGTON
JOIE ZILLER
WILMINGTON, IL
FX: 815-476-2175 EX 228
ATTN: JZILLER@WILMINGTON-IL.COM

WE PROPOSE TO FURNISH NECESSARY LABOR, EQUIPMENT AND MATERIAL TO
INSTALL THE FOLLOWING:

SEAL PARKING LOT 45,886 SQ FT

CLEAN EXISTING ASPHALT PARKING LOT. TAR CRACKS
LARGER THAN 1/4". BRUSH ON BREWER COAL TAR SEALER.
RESTRIPE PER EXISTING LAY OUT

COST.....\$8,750.00

- * OUR PRICE IS BASED ON WORK PERFORMED IN ONE CONTINUOUS OPERATION.
 - * THIS QUOTE DOES NOT INCLUDE PERMITS, BONDS, LAYOUT, TRAFFIC CONTROLOR TESTING.
 - * TERMS OF PAYMENT ARE NET 30 DAYS FROM THE DATE OF THE INVOICE. A SERVICE CHARGE OF 2% OF THE BALANCE DUE WILL BE ADDED EACH MONTH IF PAYMENT IN FULL IS NOT MADE. CUSTOMER WILL BE RESPONSIBLE FOR ALL LEGAL FEES MADE NECESSARY TO COLLECT UNPAID DEBT...
 - CONTRACTOR WILL NOT BE RESPONSIBLE FOR WATER DRAINAGE OR STANDING WATER WITH A 2% OR LESS SLOPE
 - *NOTE ANY ALTERATIONS OR DEVIATION FROM THE ABOVE SPECIFICATIONS INVOLVING EXTRA COST OR MATERIAL OR LABOR WILL ONLY BE EXECUTED UPON WRITTEN ORDERS FROM SAME, AND WILL BECOME AN EXTRA CHARGE OVER THE SUM MENTIONED IN THIS CONTRACT.
 - * THIS QUOTE IS SUBJECT TO CHANGE AT ANY GIVEN TIME DUE TO THE UNSTABLE OIL MARKET.
- ALL QUOTES MUST BE SIGNED AND FAXED BACK.

SINCERELY,

JOHN LUCAS

ACCEPTANCE:

YOU ARE HEREBY AUTHORIZED TO FURNISH ALL LABOR AND MATERIALS TO COMPLETE THE WORK MENTIONED IN THE AMOUNT ABOVE PROPOSAL, FOR WHICH THE UNDERSIGNED AGREES TO PAY THE AMOUNT MENTIONED IN SAID PROPOSAL, AND ACCORDING TO THE TERMS THEREOF.

ACCEPTED BY: _____ DATE: _____

Latinos Landscaping

P.O. Box 283
Joliet, IL 60432

Estimate

Date	Estimate #
7/9/2018	270

Name / Address
City of Wilmington 1165 South Water Street Wilmington, IL. 60481

Job Site
Police Department

Description	Total
We propose to provide equipment, labor and material to do the following work	
1.) Blow all loose gravel, debris, etc. seal coating with water base	1,204.00
2.) Striping all	510.00
<i>Wilm. Police Dept.</i>	

We look forward to doing business with you.

Proposal may be withdrawn if not signed with in 30 days

Signature _____

[Estimates](#)

Estimate #5847

[Edit](#)



SEND



PRINT



INVOICE



MORE

ESTIMATE



Wilmington Police Department

(815) 476-2813

Low Cost Sealcoating

Braceville, IL 60407

Phone: (815) 342-5759

Email: lathamtim20@yahoo.com

Estimate #

005847

Date

07/09/2018

Description	Total
Low Cost Sealcoating	\$2,950.00
Clean parking lot, apply hot rubber crack filler, apply sealer and stripe front and back parking area located at 129 Robert P Weidling Dr, Wilmington, IL 60481	
Subtotal	\$2,950.00
Total	\$2,950.00

Notes:

A deposit of 1200.00 is required upon start date.

J. LUCAS AND SONS PAVING, INC.
805 RICHARDS STREET
JOLIET, IL. 60433
PH: (815) 726-0034
FAX: (815) 726-7109

JULY 6, 2018

PREVAILING WAGE

JOB SITE: SAME

WILMINGTON POLICE DEPT
PHILLIP ARNOLD
WILMINGTON, IL
FX: 815-476-2813
ATTN: PARNOLD@WILMINGTON-IL.COM

WE PROPOSE TO FURNISH NECESSARY LABOR, EQUIPMENT AND MATERIAL TO
INSTALL THE FOLLOWING:

SEAL PARKING LOT 9,569 SQ FT
CLEAN EXISTING ASPHALT PARKING LOT. TAR CRACKS
LARGER THAN ¼". BRUSH ON BREWER COAL TAR SEALER.
RESTRIPES PER EXISTING LAY OUT
COST.....\$1,900.00

* OUR PRICE IS BASED ON WORK PERFORMED IN ONE CONTINUOUS OPERATION.
* THIS QUOTE DOES NOT INCLUDE PERMITS, BONDS, LAYOUT, TRAFFIC CONTROLOR TESTING.
* TERMS OF PAYMENT ARE NET 30 DAYS FROM THE DATE OF THE INVOICE. A SERVICE CHARGE OF 2% OF THE
BALANCE DUE WILL BE ADDED EACH MONTH IF PAYMENT IN FULL IS NOT MADE. CUSTOMER WILL BE RESPONSIBLE
FOR ALL LEGAL FEES MADE NECESSARY TO COLLECT UNPAID DEBT...
CONTRACTOR WILL NOT BE RESPONSIBLE FOR WATER DRAINAGE OR STANDING WATER WITH A 2% OR LESS SLOPE
* NOTE ANY ALTERATIONS OR DEVIATION FROM THE ABOVE SPECIFICATIONS INVOLVING EXTRA COST OR MATERIAL
OR LABOR WILL ONLY BE EXECUTED UPON WRITTEN ORDERS FROM SAME, AND WILL BECOME AN EXTRA CHARGE
OVER THE SUM MENTIONED IN THIS CONTRACT.
* THIS QUOTE IS SUBJECT TO CHANGE AT ANY GIVEN TIME DUE TO THE UNSTABLE OIL MARKET.
ALL QUOTES MUST BE SIGNED AND FAXED BACK.

SINCERELY,

JOHN LUCAS

ACCEPTANCE:
YOU ARE HEREBY AUTHORIZED TO FURNISH ALL LABOR AND MATERIALS TO COMPLETE THE WORK
MENTIONED IN THE AMOUNT ABOVE PROPOSAL, FOR WHICH THE UNDERSIGNED AGREES TO PAY THE
AMOUNT MENTIONED IN SAID PROPOSAL, AND ACCORDING TO THE TERMS THEREOF.
ACCEPTED BY: _____ DATE: _____

FY18 Fuel Costs

	Gallons	Cost	Avg price per Gallon
WEX unleaded gas	20,196	\$ 44,026	\$ 2.52
TA unleaded gas	64	\$ 164	\$ 2.57
TOTAL UNLEADED:	20,260	\$ 44,190	
TA diesel	3788	\$ 10,226	\$ 2.70
Heritage FS Dieselelex	867	\$ 1,678	\$ 1.94
Heritage FS Winterblend	379	\$ 892	\$ 2.36
Heritage FS Diesel for Generator	641	\$ 1,462	\$ 2.28
TOTAL FY18 FUEL:	25,935	\$ 58,448	
	Gallons	Cost	



CITY OF WILMINGTON

Heritage FS proposal for on site fuel storage and dispense equipment . All the equipment stated below shall be leased at no expense to the City of Wilmington.

A: 2500 gallon double wall gasoline tank

**B: 2500 gallon double wall split tank. Split wall tank will
1000 off rd DX and 1500 on rd DX**

C: 3 110 volt pumps with meters

D: 3 Hoses and 3 filtraiton systems

E: 3 automatic nosels

F: 2 MC box computer monitor system

**Heritage FS will supply IT to set up MC boxes at no expense.
City of Wilmington will be responsible for electrician to wire
up the pumps and MC Boxes**



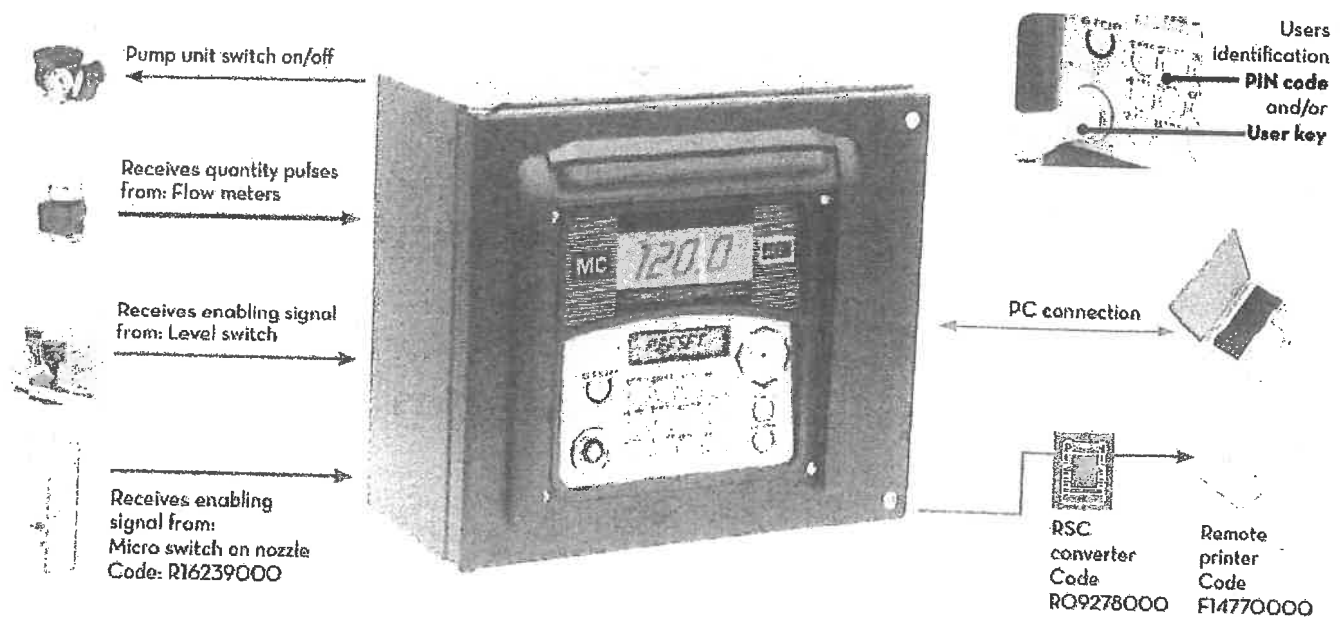

**Salesmen and delivery: Kevin Kavanaugh
8153783655**

7/10/18

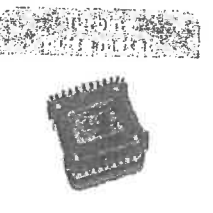

FEATURES

ON REQUEST

 K600/2-3 3/4" oil Code F00472A20 K600/3 1" diesel Code F00472A00	 K24 1" UREA Code F0040721B	 See "Fluid monitoring" section	 Code F17121000 for Diesel only
---	--	---	--

PRODUCTS RANGE TECHNICAL DATA

Code	Description	Fluids type	Users	Voltage		Meters
				AC V/Hz DC Volt	Power Watt Amp. max. (load motor)	
F0057201B	MC BOX complete *	□	80	230/50	35	K600/3
F1398000C	MC BOX (any fluids)	□ □ □	80	230/50	35	-
F1398003C	MC BOX (any fluids) 120 V	□ □ □	120	120/80	35	-
F1398005B	MC BOX (any fluids)	□ □ □	120	230/50	35	-
F1398008B	MC BOX (UREA)	□ □ □	120	230/50	35	-
F1398001B	MC BOX 12V	□ □ □	120	12	10	-
F1398002B	MC BOX 24V	□ □ □	120	24	10	-

* Complete by: CD rom with software, 10 button user key, 1 button manager key, USB plug, buttons key reader for PC

MC BOX SYSTEM

EN. Multi-user control panel with accessories for PC connection.

MC BOX permits: Pump ignition, identification of authorised users, Pre-selection of dispensed quantity, Management of pulse metro, Management of an external switch to switch off pump at minimum level, Management of micro switch connected to nozzle support, Connection to an external printer.

Technical features: Panel with dual display, keyboard and i-button reader. Controls up to 120 users through passwords or i-button keys. Calculates consumption of each individual user. Local memory up to last 255 operations. Possibility of inserting vehicle registration number, kilometres, date and time of dispensing.

Dedicated software for printing individual detailed summaries.

Possibility of managing up to 16 panels with one software. Key reader with USB socket for exporting data. RS converter with USB socket for direct connection with PC via cable up to 1000 metres.

ES. Panel electrónico de control, multiusuario, con accesorios para la conexión a una PC.

El MC BOX SYSTEM permite:

- El encendido de la bomba,
- Identificación de usuarios designados
- Preselección de la cantidad a suministrar
- Manejo del interruptor de nivel que detiene la bomba cuando el volumen del tanque está bajo.

- Manejo del interruptor localizado debajo del porta pistola para detener la bomba
- Conexión a una impresora externa.

Características: Panel de pantalla doble, teclado y lector de llave i-button. Gestión de hasta 120 usuarios mediante contraseña o llave i-button. Cálculo del consumo del periodo para cada usuario. Memoria local de las últimas 255 transacciones. Posibilidad de introducir código del vehículo y el kilometraje. Control sobre la fecha y la hora del suministro. Software especializado para efectuar impresiones de los suministros a impresiones resumidas por usuario. Posibilidad de administrar hasta 16 paneles con un software. Lector de llave con conexión USB para exportación de datos. Convertidor RS con conexión USB para PC de hasta 1000 m.

PT. Painel electrónico de controlo, para vários utilizadores com acessórios para conexão a PC.

MC BOX possibilita: Activar a bomba, Reconhecer os utilizadores habilitados, Pré selecção da quantidade a fornecer, Gestão de um contador de litros Pulser, Gestão de um interruptor de nível externo para desligar a bomba em caso de nível mínimo, Gestão de um micro interruptor coligada ao suporte da pistola, Conexão a uma impressora externa.

Características: Painel com ecrã duplo, teclado e leitor de chave i-button. Gestão de até 120 utilizadores mediante senha ou chave i-button. Cálculo do consumo por período para cada utilizador. Memória local com até os 255 últimos abastecimentos. Possibilidade de introduzir o código da viatura e a quilometragem. Gestão da data e hora do abastecimento. Software dedicado com a possibilidade de imprimir abastecimentos e sumários por utilizador. Possibilidade de gestão de até 16 painéis com um software. Leitor de chave com tomada USB para exportar dados. Conversor RS com tomada USB para conexão directa com PC via cabo de até 1.000 m.

PERFORMANCE

- Up to 120 users
- PC connection
- Data management software
- AC and DC versions available

- Capacidad de 120 usuarios
- Conexión a una PC
- Software para administrar los datos
- Disponible en versión AC y DC

- Até 120 utilizadores
- Ligação ao PC
- Software para a gestão dos dados
- Disponível na versão AC e DC

DIMENSIONS

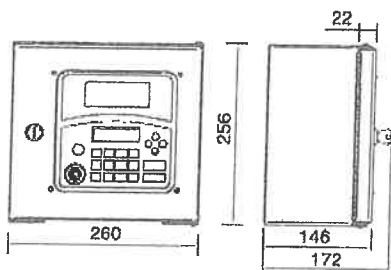

PRODUCTS RANGE WEIGHT AND PACKAGING

Code	Weight		Packaging		pcs/box
	kg	lbs	mm	inch	
F0057201B	9	19,4	480x370x265	18,9x14,6x10,4	1
F1398000C	5	19,4	480x370x265	18,9x14,6x10,4	1
F1398003C	5	19,4	480x370x265	18,9x14,6x10,4	1
F1398005B	5	19,4	480x370x265	18,9x14,6x10,4	1
F1398006B	5	19,4	480x370x265	18,9x14,6x10,4	1
F1398001B	6	13,2	480x370x265	18,9x14,6x10,4	1
F1398002B	6	13,2	480x370x265	18,9x14,6x10,4	1



Internally Protected Steel Storage Tank

Manufacturers of fuel storage tanks, such as the Fireguard tank from Highland Tank, have the expertise to help you choose and install a tank that meets all applicable regulations.

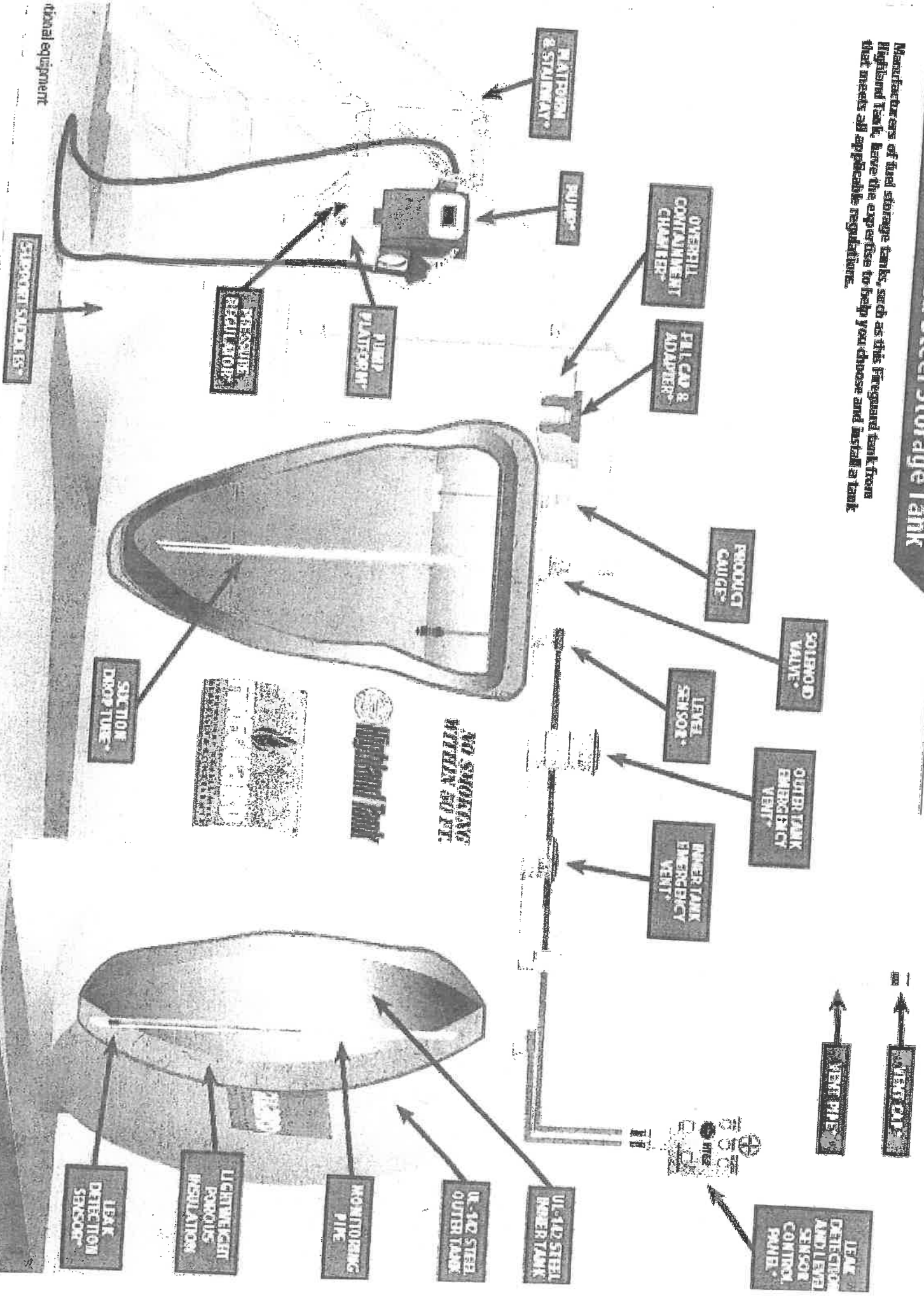

REGULATIONS FOR COMMERCIAL PETROLEUM ABOVEGROUND TANKS

Rule or Restriction	Illinois	Iowa	Wisconsin	
Setbacks				
From:			Aggregate Capacity	Distance
Buildings, Property Lines	30'	6,000 Gallon or less than 40'	100-2,000	25'
		6,000 Gallon or more than 50'	2,001-10,000	50'
			10,000-20,000	75'
			20,000-30,000	100'
Residence or Assembly	30' , 85'	100'		
Between Tanks	3'	3'		3'
Tanks				
Maximum Number	2			
Maximum Volume	2,500 Gallon	12,000 Gallon		10,000 Gallon
Maximum Aggregate Capacity	5,000 Gallon	40,000 Gallon		30,000 Gallon
Capacity				
Type of Tank	UL	UL		UL
Diking Required*	Yes	Yes		Yes
Dike Capacity	Largest Tank Plus Displacement of Other Tanks	Aggregate Capacity of Tanks		Largest Tank Plus 25%
Double Wall Allowed	Yes	Yes < 6,001 Gallon		Yes
Permit Required	Yes	Yes		Yes
Fencing	No	Yes		Yes
Tank Registration	No	Yes > 1,100 Gallon		Yes

Note: *Federal SPCC rules require diking for tanks > 1,320 Gallons or aggregate capacity of > 1,320 Gallons
9/27/2002

ORDINANCE NO. 18-07-17-02

AN ORDINANCE REPEALING THE FIREWORKS SALES OR STORAGE ORDINANCE AND AMENDING THE PROHIBITED CONDUCT ORDINANCE TO REGULATE THE POSSESSIONS AND SALE OF FIREWORKS WITHIN THE CITY OF WILMINGTON, ILLINOIS

WHEREAS, Section 11-8-4 of the Illinois Municipal Code (65 ILCS 5/11-8-4) grants authority to the City of Wilmington to regulate and prohibit fireworks in accordance with the provisions of the Pyrotechnic Use Act (425 ILCS 35/1 *et seq.*); and

WHEREAS, the City of Wilmington previously adopted Ord. 10-06-15-02 amending Section 93.04 of the Wilmington Code of Ordinances to regulate the manner in which persons, firms, or corporations may sell or offer for sale fireworks; and

WHEREAS, Section 93.01.5 of the Wilmington Code of Ordinances similarly regulates the possession and sales of fireworks; and

WHEREAS, To provide a more concise regulation of the sale of fireworks and the possession of fireworks, it is beneficial to combine Section 93.01.5 with Section 93.04 of the Wilmington Code of Ordinances; and

WHEREAS, Section 2 of the Pyrotechnic Use Act (425 ILCS 35/2) states "It shall be unlawful for any person, firm, co-partnership, or corporation to knowingly possess, offer for sale, expose for sale, sell at retail, or use or explode any display fireworks, flame effects, or consumer fireworks;" and

WHEREAS, the City of Wilmington finds and determines it is in the best interest of the City of Wilmington and its residents to prohibit the sale and use of fireworks consistent with Section 2 of the Pyrotechnic Use Act.

NOW THEREFORE, BE IT ORDAINED BY THE MAYOR AND CITY COUNCIL OF THE CITY OF WILMINGTON, WILL COUNTY, ILLINOIS, AS FOLLOWS:

SECTION 1: REPEAL AND DELETE SECTION 93.04 OF THE CITY OF WILMINGTON CODE OF ORDINANCES

That 93.04 of the Code of Ordinances of the City of Wilmington is hereby repealed and deleted.

SECTION 2: AMEND 93.01.5 OF THE CITY OF WILMINGTON CODE OF ORDINANCES

That 93.01.5 of the Code of Ordinances of the City of Wilmington is hereby amended to the following:

93.01.5 Prohibited Conduct

- (A) It shall be unlawful for any person to violate any provision of the (425 ILCS 30/1 *et seq.*), the Fireworks Use Act (425 ILCS 35/1 *et seq.*) or any rule or regulation promulgated by the State Fire Marshal pursuant to said acts.

- (B) Except as hereinafter provided, it shall be unlawful for any person, firm, co-partnership, or corporation to knowingly possess, offer for sale, expose for sale, sell, or keep for the purpose of sale any display fireworks, flame effects, consumer fireworks, or fireworks otherwise prohibited from sale by Section 2 of the Pyrotechnic Use Act (425 ILCS 35/2).
- (C) Nothing in this chapter shall be construed as prohibiting the manufacture, storage or use of signals or fuses necessary for the safe operation of railroads, trucks, aircraft or other instrumentalities of transportation.

SECTION 3: EFFECTIVE DATE

This Ordinance shall be in full force and effect from and after its passage, approval and publication as provided by law, but not until 30 days after the election authorities having jurisdiction in the area in which the name of street is changed and the post office branch serving that area have been notified by the corporate authority in writing by certified or registered mail.

SECTION 4: SEVERABILITY

If any section, paragraph, subdivision, clause, sentence or provision of this Ordinance shall be adjudged by any Court of competent jurisdiction to be invalid, such judgment shall not affect, impair, invalidate or nullify the remainder thereof, which remainder shall remain and continue in full force and effect.

SECTION 5: REPEALER

All ordinances or parts of ordinances conflicting with any provisions of this ordinance are hereby repealed.

PASSED this ____ day of _____, 2018 with ____ members voting aye, ____ members voting nay, the Mayor voting _____, with ____ members abstaining or passing and said vote being:

John Persic, Jr.	_____	Kevin Kirwin	_____
Fran Tutor	_____	David Vice	_____
Steve Evans	_____	Lisa Butler	_____
Floyd Combes	_____	Frank Studer	_____

Approved this ____ day of _____, 2018

Roy Strong, Mayor

Attest:

Joie Ziller, Deputy City Clerk

ORDINANCE NO. 18-07-17-03

AN ORDINANCE AMENDING THE SALARY OF THE CITY CLERK

WHEREAS, the City of Wilmington (hereinafter "City") is an Illinois municipal corporation; and

WHEREAS, City of Wilmington has the authority to fix the salaries for all municipal officers; and

WHEREAS, Subsection C of "Section 30.09" Compensation of certain officers and officials" of Title III "Administration of Wilmington" Code of Ordinances provides for the compensation of the City Clerk; and

WHEREAS, On December 21, 2004, a motion was passed at a City Council meeting to increase the City Clerk's salary from \$1,800 to \$2,400;

WHEREAS, Section 30.09(C) of Wilmington's Code of Ordinances was never updated to provide for the salary approved by the December 21, 2004 motion.

WHEREAS, the City of Wilmington finds and determines it is in the best interest of the City of Wilmington and its residents to update and amend Subsection (C) of "Section 30.09" Compensation of certain officers and officials" of Title III "Administration of Wilmington" Code of Ordinances to fix the City Clerk salary at \$2,400 per annum, payable quarterly.

NOW THEREFORE, BE IT ORDAINED BY THE MAYOR AND CITY COUNCIL OF THE CITY OF WILMINGTON, WILL COUNTY, ILLINOIS, AS FOLLOWS:

SECTION 1: AMEND SUBSECTION (C) OF SECTION 30.09 OF THE CITY OF WILMINGTON CODE OF ORDINANCES

That Subsection (C) of Section 30.09 "Compensation of certain officers and officials of Title III "Administration of the City of Wilmington Code of Ordinances is hereby amended to the following:

30.09 "Compensation of certain officers and officials.

1 .

(C) City Clerk. That salary of the City Clerk is fixed at \$2,400 per annum, payable quarterly.

SECTION 2: REPEALER

All ordinances or parts of ordinances conflicting with any provisions of this ordinance are hereby repealed.

SECTION 3: SEVERABILITY

If any section, paragraph, subdivision, clause, sentence or provision of this Ordinance shall be adjudged by any Court of competent jurisdiction to be invalid, such judgment shall not affect, impair, invalidate or nullify the remainder thereof, which remainder shall remain and continue in full force and effect.

SECTION 4: EFFECTIVE DATE

This Ordinance shall be in full force and effect from and after its passage, approval and publication as provided by law.

PASSED this ____ day of _____, 2018 with ____ members voting aye, ____ members voting nay, the Mayor voting ____, with ____ members abstaining or passing and said vote being:

John Persic, Jr.	_____	Kevin Kirwin	_____
Fran Tutor	_____	David Vice	_____
Steve Evans	_____	Lisa Butler	_____
Floyd Combes	_____	Frank Studer	_____

Approved this ____ day of _____, 2018

Roy Strong, Mayor

Attest:

Joie Ziller, Deputy City Clerk

ORDINANCE NO. 18-07-17-05

**AN ORDINANCE AMENDING THE ORDINANCE RELATING TO
ORDER OF BUSINESS FOR CITY COUNCIL MEETINGS**

WHEREAS, the City of Wilmington (hereinafter "City") is an Illinois municipal corporation; and

WHEREAS, the Illinois Municipal Code (65 ILCS 5/1 et. seq.) provides municipalities the authority to determine its own rules of proceeding;

WHEREAS, Section 31.21 Order of Business in Wilmington's Code of Ordinances provides for orders of business that are outdated and no longer applicable or relevant to the City of Wilmington's current business affairs;

WHEREAS, the City of Wilmington finds and determines it is in the best interest of the City of Wilmington and its residents to update and amend Section 31.21 Order of Business;

NOW THEREFORE, BE IT ORDAINED BY THE MAYOR AND CITY COUNCIL OF THE CITY OF WILMINGTON, WILL COUNTY, ILLINOIS, AS FOLLOWS:

SECTION 1: AMEND 31.21 OF THE CITY OF WILMINGTON CODE OF ORDINANCES

That 31.21 ORDER OF BUSINESS of TITLE III ADMINISTRATION of the Code of Ordinances of the City of Wilmington is hereby amended to the following:

31.21 Order of Business.

The order of business at meetings of the city council shall be as follows:

- (A) Pledge to the flag;
- (B) Approval of minutes;
- (C) Mayor's report;
- (D) Citizen's comments;
- (E) Planning and zoning commission report;
- (F) Committee reports;
- (G) City administrator's report;
- (H) Attorney's report;
- (I) Anyone wanting to be on the agenda will notify the mayor or city clerk at least four days prior to the regular meeting.

SECTION 2: REPEALER

All ordinances or parts of ordinances conflicting with any provisions of this ordinance are hereby repealed.

SECTION 3: SEVERABILITY

If any section, paragraph, subdivision, clause, sentence or provision of this Ordinance shall be adjudged by any Court of competent jurisdiction to be invalid, such judgment shall not affect, impair, invalidate or nullify the remainder thereof, which remainder shall remain and continue in full force and effect.

SECTION 4: EFFECTIVE DATE

This Ordinance shall be in full force and effect from and after its passage, approval and publication as provided by law.

PASSED this ____ day of _____, 2018 with ____ members voting aye, ____ members voting nay, the Mayor voting _____, with ____ members abstaining or passing and said vote being:

John Persic, Jr.	_____	Kevin Kirwin	_____
Fran Tutor	_____	David Vice	_____
Steve Evans	_____	Lisa Butler	_____
Floyd Combes	_____	Frank Studer	_____

Approved this ____ day of _____, 2018

Roy Strong, Mayor

Attest:

Joie Ziller, Deputy City Clerk

ORDINANCE NO. 18-07-17-06

AN ORDINANCE PROVIDING FOR THE REGULATION OF AND APPLICATION FOR SMALL WIRELESS FACILITIES

WHEREAS, the City of Wilmington (the "City") is an Illinois municipality in accordance with the Constitution of the State of Illinois of 1970; and

WHEREAS, the Illinois General Assembly has recently enacted Public Act 100-0585, known as the Small Wireless Facilities Deployment Act (the "Act"), effective June 1, 2018; and

WHEREAS, the Act sets forth the requirements for the collocation of small wireless facilities by local authorities; and

WHEREAS, the City is authorized, under existing State and federal law, to enact appropriate regulations and restrictions relative to small wireless facilities, distributed antenna systems and other personal wireless telecommunication facility installations in the public right-of-way as long as it does not conflict with State and federal law.

NOW THEREFORE, BE IT ORDAINED BY THE MAYOR AND CITY COUNCIL OF THE CITY OF WILMINGTON, WILL COUNTY, ILLINOIS, AS FOLLOWS:

SECTION 1. INCORPORATION OF RECITALS

That the recitals set forth above are incorporated here by reference.

SECTION 2. ADOPTION

CHAPTER 165: SMALL WIRELESS FACILITIES of TITLE XV: LAND USAGE is hereby created and adopted:

165.01 Purpose and Scope.

Purpose. The purpose of this Ordinance is to establish regulations, standards and procedures for the siting and collocation of small wireless facilities on rights-of-way within the City's jurisdiction, or outside the rights-of-way on property zoned by the City exclusively for commercial or industrial use, in a manner that is consistent with the Act.

Conflicts with Other Ordinances. This Ordinance supersedes all Ordinances or parts of Ordinances adopted prior hereto that are in conflict herewith, to the extent of such conflict.

Conflicts with State and Federal Laws. In the event that applicable federal or State laws or regulations conflict with the requirements of this Ordinance, the wireless provider shall comply with the requirements of this Ordinance to the maximum extent possible without violating federal or State laws or regulations.

165.02 Definitions.

For the purposes of this Ordinance, the following terms shall have the following meanings:

Antenna ó communications equipment that transmits or receives electromagnetic radio frequency signals used in the provision of wireless services.

Applicable codes ó uniform building, fire, electrical, plumbing, or mechanical codes adopted by a recognized national code organization or local amendments to those codes, including the National Electric Safety Code.

Applicant ó any person who submits an application and is a wireless provider.

Application ó a request submitted by an applicant to the City for a permit to collocate small wireless facilities, and a request that includes the installation of a new utility pole for such collocation, as well as any applicable fee for the review of such application.

Collocate or collocation ó to install, mount, maintain, modify, operate, or replace wireless facilities on or adjacent to a wireless support structure or utility pole.

Communications service ó cable service, as defined in 47 U.S.C. 522(6), as amended; information service, as defined in 47 U.S.C. 153(24), as amended; telecommunications service, as defined in 47 U.S.C. 153(53), as amended; mobile service, as defined in 47 U.S.C. 153(53), as amended; or wireless service other than mobile service.

Communications service provider ó a cable operator, as defined in 47 U.S.C. 522(5), as amended; a provider of information service, as defined in 47 U.S.C. 153(24), as amended; a telecommunications carrier, as defined in 47 U.S.C. 153(51), as amended; or a wireless provider.

FCC ó the Federal Communications Commission of the United States.

Fee ó a one-time charge.

Historic district or **historic landmark** ó a building, property, or site, or group of buildings, properties, or sites that are either (i) listed in the National Register of Historic Places or formally determined eligible for listing by the Keeper of the National Register, the individual who has been delegated the authority by the federal agency to list properties and determine their eligibility for the National Register, in accordance with Section VI.D.1.a.i through Section VI.D.1.a.v of the Nationwide Programmatic Agreement codified at 47 CFR Part 1, Appendix C; or (ii) designated as a locally landmarked building, property, site, or historic district by an ordinance adopted by the City pursuant to a preservation program that meets the requirements of the Certified Local Government Program of the Illinois State Historic Preservation Office or where such certification of the preservation program by the Illinois State Historic Preservation Office is pending.

Law ó a federal or State statute, common law, code, rule, regulation, order, or local ordinance or resolution.

Micro wireless facility ó a small wireless facility that is not larger in dimension than 24 inches in length, 15 inches in width, and 12 inches in height and that has an exterior antenna, if any, no longer than 11 inches.

Municipal utility pole ó a utility pole owned or operated by the City in public rights-of-way.

Permit ó a written authorization required by the City to perform an action or initiate, continue, or complete a project.

Person ó an individual, corporation, limited liability company, partnership, association, trust, or other entity or organization.

Public safety agency ó the functional division of the federal government, the State, a unit of local government, or a special purpose district located in whole or in part within this State, that provides or has authority to provide firefighting, police, ambulance, medical, or other emergency services to respond to and manage emergency incidents.

Rate ó a recurring charge.

Right-of-way ó the area on, below, or above a public roadway, highway, street, public sidewalk, alley, or utility easement dedicated for compatible use. Right-of-way does not include City-owned aerial lines.

Small wireless facility ó a wireless facility that meets both of the following qualifications: (i) each antenna is located inside an enclosure of no more than 6 cubic feet in volume or, in the case of an antenna that has exposed elements, the antenna and all of its exposed elements could fit within an imaginary enclosure of no more than 6 cubic feet; and (ii) all other wireless equipment attached directly to a utility pole associated with the facility is cumulatively no more than 25 cubic feet in volume. The following types of associated ancillary equipment are not included in the calculation of equipment volume: electric meter, concealment elements, telecommunications

demarcation box, ground-based enclosures, grounding equipment, power transfer switch, cut-off switch, and vertical cable runs for the connection of power and other services.

Utility pole ó a pole or similar structure that is used in whole or in part by a communications service provider or for electric distribution, lighting, traffic control, or a similar function.

Wireless facility ó equipment at a fixed location that enables wireless communications between user equipment and a communications network, including: (i) equipment associated with wireless communications; and (ii) radio transceivers, antennas, coaxial or fiber-optic cable, regular and backup power supplies, and comparable equipment, regardless of technological configuration. Wireless facility includes small wireless facilities. Wireless facility does not include: (i) the structure or improvements on, under, or within which the equipment is collocated; or (ii) wireline backhaul facilities, coaxial or fiber optic cable that is between wireless support structures or utility poles or coaxial, or fiber optic cable that is otherwise not immediately adjacent to or directly associated with an antenna.

Wireless infrastructure provider ó any person authorized to provide telecommunications service in the State that builds or installs wireless communication transmission equipment, wireless facilities, wireless support structures, or utility poles and that is not a wireless services provider but is acting as an agent or a contractor for a wireless services provider for the application submitted to the City.

Wireless provider ó a wireless infrastructure provider or a wireless services provider.

Wireless services ó any services provided to the general public, including a particular class of customers, and made available on a nondiscriminatory basis using licensed or unlicensed spectrum, whether at a fixed location or mobile, provided using wireless facilities.

Wireless services provider ó a person who provides wireless services.

Wireless support structure ó a freestanding structure, such as a monopole; tower, either guyed or self-supporting; billboard; or other existing or proposed structure designed to support or capable of supporting wireless facilities. Wireless support structure does not include a utility pole.

165.03 Regulation of Small Wireless Facilities.

- (A) **Permitted Use.** Small wireless facilities shall be classified as permitted uses and subject to administrative review, except as provided in paragraph (9) regarding Height Exceptions or Variances, but not subject to zoning review or approval if they are collocated (i) in rights-of-way in any zoning district, or (ii) outside rights-of-way in property zoned exclusively for commercial or industrial use.
- (B) **Permit Required.** An applicant shall obtain one or more permits from the City to collocate a small wireless facility. An application shall be received and processed, and permits issued shall be subject to the following conditions and requirements:

- (1) Application Requirements. A wireless provider shall provide the following information to the City, together with the City's Small Cell Facilities Permit Application, as a condition of any permit application to collocate small wireless facilities on a utility pole or wireless support structure:
- a. Site specific structural integrity and, for a municipal utility pole, make-ready analysis prepared by a structural engineer, as that term is defined in Section 4 of the Structural Engineering Practice Act of 1989;
 - b. The location where each proposed small wireless facility or utility pole would be installed and photographs of the location and its immediate surroundings depicting the utility poles or structures on which each proposed small wireless facility would be mounted or location where utility poles or structures would be installed. This should include a depiction of the completed facility;
 - c. Specifications and drawings prepared by a structural engineer, as that term is defined in Section 4 of the Structural Engineering Practice Act of 1989, for each proposed small wireless facility covered by the application as it is proposed to be installed;
 - d. The equipment type and model numbers for the antennas and all other wireless equipment associated with the small wireless facility;
 - e. A proposed schedule for the installation and completion of each small wireless facility covered by the application, if approved; and
 - f. Certification that the collocation complies with the Collocation Requirements and Conditions contained herein, to the best of the applicant's knowledge.
 - g. In the event that the proposed small wireless facility is to be attached to an existing pole owned by an entity other than the City, the wireless provider shall provide legally competent evidence of the consent of the owner of such pole to the proposed collocation.

(2) Application Process. The City shall process applications as follows:

- a. The first completed application shall have priority over applications received by different applicants for collocation on the same utility pole or wireless support structure.
- b. An application to collocate a small wireless facility on an existing utility pole or wireless support structure, or replacement of an existing utility pole or wireless support structure shall be processed on a nondiscriminatory basis and shall be deemed approved if the City fails to approve or deny the application within 90 days after the submission of a completed application.

However, if an applicant intends to proceed with the permitted activity on a deemed approved basis, the applicant shall notify the City in writing of its intention to invoke the deemed approved remedy no sooner than 75 days after the submission of a completed application.

The permit shall be deemed approved on the latter of the 90th day after submission of the complete application or the 10th day after the receipt of the deemed approved notice by the City. The receipt of the deemed approved notice shall not preclude the City's denial of the permit request within the time limits as provided under this Ordinance.

- c. An application to collocate a small wireless facility that includes the installation of a new utility pole shall be processed on a nondiscriminatory basis and deemed approved if the City fails to approve or deny the application within 120 days after the submission of a completed application.

However, if an applicant intends to proceed with the permitted activity on a deemed approved basis, the applicant shall notify the City in writing of its intention to invoke the deemed approved remedy no sooner than 105 days after the submission of a completed application.

The permit shall be deemed approved on the latter of the 120th day after submission of the complete application or the 10th day after the receipt of the deemed approved notice by the City. The receipt of the deemed approved notice shall not preclude the City's denial of the permit request within the time limits as provided under this Ordinance.

- d. The City shall deny an application which does not meet the requirements of this Ordinance.

If the City determines that applicable codes, ordinances or regulations that concern public safety, or the Collocation Requirements and Conditions contained herein require that the utility pole or wireless support structure be replaced before the requested collocation, approval shall be conditioned on the replacement of the utility pole or wireless support structure at the cost of the provider.

The City shall document the basis for a denial, including the specific code provisions or application conditions on which the denial is based, and send the documentation to the applicant on or before the day the City denies an application.

The applicant may cure the deficiencies identified by the City and resubmit the revised application once within 30 days after notice of denial is sent to the applicant without paying an additional application fee. The City shall approve or deny the revised application within 30 days after the applicant resubmits the application or it is deemed approved. Failure to resubmit the revised

application within 30 days of denial shall require the application to submit a new application with applicable fees, and recommencement of the City's review period.

The applicant must notify the City in writing of its intention to proceed with the permitted activity on a deemed approved basis, which may be submitted with the revised application.

Any review of a revised application shall be limited to the deficiencies cited in the denial. However, this revised application does not apply if the cure requires the review of a new location, new or different structure to be collocated upon, new antennas, or other wireless equipment associated with the small wireless facility.

- e. Pole Attachment Agreement. Within 30 days after an approved permit to collocate a small wireless facility on a municipal utility pole, the City and the applicant shall enter into a Master Pole Attachment Agreement, provided by the City for the initial collocation on a municipal utility pole by the application. For subsequent approved permits to collocate on a small wireless facility on a municipal utility pole, the City and the applicant shall enter into a License Supplement of the Master Pole Attachment Agreement.

- (3) Completeness of Application. Within 30 days after receiving an application, the City shall determine whether the application is complete and notify the applicant. If an application is incomplete, the City must specifically identify the missing information. An application shall be deemed complete if the City fails to provide notification to the applicant within 30 days after all documents, information and fees specifically enumerated in the City's permit application form are submitted by the applicant to the City.

Processing deadlines are tolled from the time the City sends the notice of incompleteness to the time the applicant provides the missing information.

- (4) Tolling. The time period for applications may be further tolled by:
 - a. An express written agreement by both the applicant and the City; or
 - b. A local, State or federal disaster declaration or similar emergency that causes the delay.
- (5) Consolidated Applications. An applicant seeking to collocate small wireless facilities within the jurisdiction of the City shall be allowed, at the applicant's discretion, to file a consolidated application and receive a single permit for the collocation of up to 25 small wireless facilities if the collocations each involve substantially the same type of small wireless facility and substantially the same type of structure.

If an application includes multiple small wireless facilities, the City may remove small wireless facility collocations from the application and treat separately small wireless facility collocations for which incomplete information has been provided or that do not qualify for consolidated treatment or that are denied. The City may issue separate permits for each collocation that is approved in a consolidated application.

- (6) Duration of Permits. The duration of a permit shall be for a period of 5 years, and the permit shall be renewed for equivalent durations unless the City makes a finding that the small wireless facilities or the new or modified utility pole do not comply with the applicable City codes or any provision, condition or requirement contained in this Ordinance.

If the Act is repealed as provided in Section 90 therein, renewals of permits shall be subject to the applicable City code provisions or regulations in effect at the time of renewal.

- (7) Means of Submitting Applications. Applicants shall submit applications, supporting information and notices to the City by personal delivery at the City's designated place of business, by regular mail postmarked on the date due or by any other commonly used means, including electronic mail.

(C) Collocation Requirements and Conditions.

- (1) Public Safety Space Reservation. The City may reserve space on municipal utility poles for future public safety uses, for the City's electric utility uses, or both, but a reservation of space may not preclude the collocation of a small wireless facility unless the City reasonably determines that the municipal utility pole cannot accommodate both uses.
- (2) Installation and Maintenance. The wireless provider shall install, maintain, repair and modify its small wireless facilities in safe condition and good repair and in compliance with the requirements and conditions of this Ordinance. The wireless provider shall ensure that its employees, agents or contractors that perform work in connection with its small wireless facilities are adequately trained and skilled in accordance with all applicable industry and governmental standards and regulations.
- (3) No interference with public safety communication frequencies. The wireless provider's operation of the small wireless facilities shall not interfere with the frequencies used by a public safety agency for public safety communications.

A wireless provider shall install small wireless facilities of the type and frequency that will not cause unacceptable interference with a public safety agency's communications equipment.

Unacceptable interference will be determined by and measured in accordance with industry standards and the FCC's regulations addressing unacceptable interference to public safety spectrum or any other spectrum licensed by a public safety agency.

If a small wireless facility causes such interference, and the wireless provider has been given written notice of the interference by the public safety agency, the wireless provider, at its own expense, shall remedy the interference in a manner consistent with the abatement and resolution procedures for interference with public safety spectrum established by the FCC including 47 CFR 22.970 through 47 CFR 22.973 and 47 CFR 90.672 through 47 CFR 90.675.

The City may terminate a permit for a small wireless facility based on such interference if the wireless provider is not in compliance with the Code of Federal Regulations cited in the previous paragraph. Failure to remedy the interference as required herein shall constitute a public nuisance.

- (4) The wireless provider shall not collocate small wireless facilities on City utility poles that are part of an electric distribution or transmission system within the communication worker safety zone of the pole or the electric supply zone of the pole.

However, the antenna and support equipment of the small wireless facility may be located in the communications space on the City utility pole and on the top of the pole, if not otherwise unavailable, if the wireless provider complies with applicable codes for work involving the top of the pole.

For purposes of this subparagraph, the terms "communications space", "communication worker safety zone", and "electric supply zone" have the meanings given to those terms in the National Electric Safety Code as published by the Institute of Electrical and Electronics Engineers.

- (5) The wireless provider shall comply with all applicable codes and local code provisions or regulations that concern public safety.
- (6) The wireless provider shall comply with written design standards that are generally applicable for decorative utility poles, or reasonable stealth, concealment and aesthetic requirements that are set forth in a City ordinance, written policy adopted by the City, a comprehensive plan or other written design plan that applies to other occupiers of the rights-of-way, including on a historic landmark or in a historic district.
- (7) Alternate Placements. Except as provided in this Collocation Requirements and Conditions Section, a wireless provider shall not be required to collocate small wireless facilities on any specific utility pole, or category of utility poles, or be required to collocate multiple antenna systems on a single utility pole. However, with respect to an application for the collocation of a small wireless facility associated with a new utility pole, the City may propose that the small wireless facility be collocated on an existing utility pole or existing wireless support structure within 100

feet of the proposed collocation, which the applicant shall accept if it has the right to use the alternate structure on reasonable terms and conditions, and the alternate location and structure does not impose technical limits or additional material costs as determined by the applicant.

If the applicant refuses a collocation proposed by the City, the applicant shall provide written certification describing the property rights, technical limits or material cost reasons the alternate location does not satisfy the criteria in this paragraph.

- (8) Height Limitations. The maximum height of a small wireless facility shall be no more than 10 feet above the utility pole or wireless support structure on which the small wireless facility is collocated.

New or replacement utility poles or wireless support structures on which small wireless facilities are collocated may not exceed the higher of:

- a. 10 feet in height above the tallest existing utility pole, other than a utility pole supporting only wireless facilities, that is in place on the date the application is submitted to the City, that is located within 300 feet of the new or replacement utility pole or wireless support structure and that is in the same right-of-way within the jurisdictional boundary of the City, provided the City may designate which intersecting right-of-way within 300 feet of the proposed utility pole or wireless support structures shall control the height limitation for such facility; or
- b. 45 feet above ground level.

- (9) Height Exceptions or Variances. If an applicant proposes a height for a new or replacement pole in excess of the above height limitations on which the small wireless facility is proposed for collocation, the applicant shall apply for a variance in conformance with procedures, terms and conditions set forth in Sections 150.12 and 150.18 of Wilmington's Code of Ordinances.

- (10) Contractual Design Requirements. The wireless provider shall comply with requirements that are imposed by a contract between the City and a private property owner that concern design or construction standards applicable to utility poles and ground-mounted equipment located in the right-of-way.

- (11) Ground-mounted Equipment Spacing. The wireless provider shall comply with applicable spacing requirements in applicable codes and ordinances concerning the location of ground-mounted equipment located in the right-of-way if the requirements include a waiver, zoning or other process that addresses wireless provider requests for exception or variance and do not prohibit granting of such exceptions or variances.

- (12) Undergrounding Regulations. The wireless provider shall comply with local code provisions or regulations concerning undergrounding requirements that prohibit the

installation of new or the modification of existing utility poles in a right-of-way without prior approval if the requirements include a waiver, zoning or other process that addresses requests to install such new utility poles or modify such existing utility poles and do not prohibit the replacement of utility poles.

- (13) Collocation Completion Deadline. Collocation for which a permit is granted shall be completed within 180 days after issuance of the permit, unless the City and the wireless provider agree to extend this period or a delay is caused by make-ready work for a municipal utility pole or by the lack of commercial power or backhaul availability at the site, provided the wireless provider has made a timely request within 60 days after the issuance of the permit for commercial power or backhaul services, and the additional time to complete installation does not exceed 360 days after issuance of the permit. Otherwise, the permit shall be void unless the City grants an extension in writing to the applicant.

(D) Application Fees. Application fees are imposed as follows:

- (1) Applicant shall pay an application fee of \$650 for an application to collocate a single small wireless facility on an existing utility pole or wireless support structure, and \$350 for each small wireless facility addressed in a consolidated application to collocate more than one small wireless facility on existing utility poles or wireless support structures.
- (2) Applicant shall pay an application fee of \$1,000 for each small wireless facility addressed in an application that includes the installation of a new utility pole for such collocation.
- (3) Notwithstanding any contrary provision of State law or local ordinance, applications pursuant to this Section shall be accompanied by the required application fee. Application fees shall be non-refundable.
- (4) The City shall not require an application, approval or permit, or require any fees or other charges, from a communications service provider authorized to occupy the rights-of-way, for:
 - a. routine maintenance;
 - b. the replacement of wireless facilities with wireless facilities that are substantially similar, the same size, or smaller if the wireless provider notifies the City at least 10 days prior to the planned replacement and includes equipment specifications for the replacement of equipment consistent with subsection d. under the Section titled Application Requirements; or
 - c. the installation, placement, maintenance, operation or replacement of micro wireless facilities suspended on cables that are strung between existing utility poles in compliance with applicable safety codes.

(5) Wireless providers shall secure a permit from the City to work within rights-of-way for activities that affect traffic patterns or require lane closures.

(E) Exceptions to Applicability. Nothing in this Ordinance authorizes a person to collocate small wireless facilities on:

- (1) property owned by a private party or property owned or controlled by the City or another unit of local government that is not located within rights-of-way, or a privately owned utility pole or wireless support structure without the consent of the property owner;
- (2) property owned, leased, or controlled by a park district, forest preserve district, or conservation district for public park, recreation or conservation purposes without the consent of the affected district, excluding the placement of facilities on rights-of-way located in an affected district that are under the jurisdiction and control of a different unit of local government as provided by the Illinois Highway Code; or
- (3) property owned by a rail carrier registered under Section 18c-7201 of the Illinois Vehicle Code, Metra Commuter Rail or any other public commuter rail service, or an electric utility as defined in Section 16-102 of the Public Utilities Act, without the consent of the rail carrier, public commuter rail service, or electric utility. The provisions of this Ordinance do not apply to an electric or gas public utility or such utility's wireless facilities if the facilities are being used, developed and maintained consistent with the provisions of subsection (i) of Section 16-108.5 of the Public Utilities Act.

For the purposes of this subsection, "public utility" has the meaning given to that term in Section 3-105 of the Public Utilities Act. Nothing in this Ordinance shall be construed to relieve any person from any requirement (a) to obtain a franchise or a State-issued authorization to offer cable service or video service or (b) to obtain any required permission to install, place, maintain, or operate communications facilities, other than small wireless facilities subject to this Ordinance.

(F) Pre-Existing Agreements. Existing agreements between the City and wireless providers that relate to the collocation of small wireless facilities in the right-of-way, including the collocation of small wireless facilities on City utility poles, that are in effect on June 1, 2018, remain in effect for all small wireless facilities collocated on the City's utility poles pursuant to applications submitted to the City before June 1, 2018, subject to applicable termination provisions contained therein. Agreements entered into after June 1, 2018, shall comply with this Ordinance.

A wireless provider that has an existing agreement with the City on the effective date of the Act may accept the rates, fees and terms that the City makes available under this Ordinance for the collocation of small wireless facilities or the installation of new utility poles for the collocation of small wireless facilities that are the subject of an application submitted two or more years after the effective date of the Act by notifying the City that it opts to accept such rates, fees and terms. The existing agreement remains in effect, subject to applicable

termination provisions, for the small wireless facilities the wireless provider has collocated on the City's utility poles pursuant to applications submitted to the City before the wireless provider provides such notice and exercises its option under this paragraph.

- (G) Annual Recurring Rate.** A wireless provider shall pay to the City an annual recurring rate to collocate a small wireless facility on a City utility pole located in a right-of-way that equals (i) \$200 per year or (ii) the actual, direct and reasonable costs related to the wireless provider's use of space on the City utility pole.

If the City has not billed the wireless provider actual and direct costs, the fee shall be \$200 payable on the first day after the first annual anniversary of the issuance of the permit or notice of intent to collocate, and on each annual anniversary date thereafter.

- (H) Abandonment.** A small wireless facility that is not operated for a continuous period of 12 months shall be considered abandoned. The owner of the facility shall remove the small wireless facility within 90 days after receipt of written notice from the City notifying the wireless provider of the abandonment.

The notice shall be sent by certified or registered mail, return receipt requested, by the City to the owner at the last known address of the wireless provider. If the small wireless facility is not removed within 90 days of such notice, the City may remove or cause the removal of such facility pursuant to the terms of its pole attachment agreement for municipal utility poles or through whatever actions are provided for abatement of nuisances or by other law for removal and cost recovery.

A wireless provider shall provide written notice to the City if it sells or transfers small wireless facilities within the jurisdiction of the City. Such notice shall include the name and contact information of the new wireless provider.

165.04 Dispute Resolution.

The Circuit Court of Will shall have exclusive jurisdiction to resolve all disputes arising under the Small Wireless Facilities Deployment Act. Pending resolution of a dispute concerning rates for collocation of small wireless facilities on municipal utility poles within the right-of-way, the City shall allow the collocating person to collocate on its poles at annual rates of no more than \$200 per year per municipal utility pole, with rates to be determined upon final resolution of the dispute.

165.05 Indemnification.

A wireless provider shall indemnify and hold the City harmless against any and all liability or loss from personal injury or property damage resulting from or arising out of, in whole or in part, the use or occupancy of the City improvements or right-of-way associated with such improvements by the wireless provider or its employees, agents, or contractors arising out of the

rights and privileges granted under this Ordinance and the Act. A wireless provider has no obligation to indemnify or hold harmless against any liabilities and losses as may be due to or caused by the sole negligence of the City or its employees or agents. A wireless provider shall further waive any claims that they may have against the City with respect to consequential, incidental, or special damages, however caused, based on the theory of liability.

165.06 Insurance.

The wireless provider shall carry, at the wireless provider's own cost and expense, the following insurance:

- (i) property insurance for its property's replacement cost against all risks;
- (ii) workers' compensation insurance, as required by law;

OR

(iii) commercial general liability insurance with respect to its activities on the City improvements or rights-of-way to afford minimum protection limits consistent with its requirements of other users of City improvements or rights-of-way, including coverage for bodily injury and property damage.

The wireless provider shall include the City as an additional insured on the commercial general liability policy and provide certification and documentation of inclusion of the City in a commercial general liability policy prior to the collocation of any wireless facility.

A wireless provider may self-insure all or a portion of the insurance coverage and limit requirement required by the City. A wireless provider that self-insures is not required, to the extent of the self-insurance, to comply with the requirement for the name of additional insureds under this Section. A wireless provider that elects to self-insure shall provide to the City evidence sufficient to demonstrate its financial ability to self-insure the insurance coverage limits required by the City.

SECTION 3. **SEVERABILITY**

This Ordinance and every provision thereof shall be considered severable, and the invalidity of any section, clause, paragraph, sentence, or provision of this Ordinance shall not affect the validity of any other portion of this Ordinance.

SECTION 4. **REPEALER**

All ordinances or parts of ordinances conflicting with any provisions of this Ordinance are hereby repealed.

SECTION 5. EFFECTIVE DATE

This Ordinance shall be effective after its passage, approval and publication in pamphlet form.

PASSED this ____ day of _____, 2018 with ____ members voting aye, ____ members voting nay, the Mayor voting _____, with ____ members abstaining or passing and said vote being:

John Persic, Jr.	_____	Kevin Kirwin	_____
Fran Tutor	_____	David Vice	_____
Steve Evans	_____	Lisa Butler	_____
Floyd Combes	_____	Frank Studer	_____

Approved this ____ day of _____, 2018

Roy Strong, Mayor

Attest:

Joie Ziller, Deputy City Clerk