



**City of Wilmington
1165 South Water Street
Wilmington, IL 60481**

**Agenda - Regular City Council Meeting
Wilmington City Hall - Council Chambers
July 18, 2023 at 7:00 p.m.**

A. CALL TO ORDER

1. Pledge of Allegiance
2. Roll Call

Mayor Ben Dietz

Alderspersons: Kevin Kirwin, Ryan Jeffries, Dennis Vice, Ryan Knight
Leslie Allred, Jonathan Mietzner, Thomas Smith, Todd Holmes

B. CITIZENS COMMENT *(State your full name clearly; limit 3 minutes each)*

C. CONSENT AGENDA

All items listed on the Consent Agenda are considered to be routine by the City Council and will be acted upon with one motion. There will be no separate discussion of these items unless a Council member requests, in which event, the items will be removed from the consent agenda and discussed separately.

1. Approval of the Regular Meeting Minutes July 5, 2023
2. Approval of the Accounts Payable Report
3. Approval of Ordinance 23-07-18-02, An Ordinance Amending Title XI Business Regulations Regarding Fees For Certain Business Licenses, Repealing Certain Articles and Chapters, and Renumbering Certain Articles and Chapters
4. Approval of Ordinance 23-07-18-03, An Ordinance of the City of Wilmington Amending Its Liquor License Ordinances to Include a Class J Liquor License Permitting the Sale of Alcoholic Liquor on Premises for Live Events at Movie Theater Establishments
5. Approve Gaskill & Walton Construction Company Proposal to Rehabilitate North Island Lift Station for a cost of \$289,000
6. Approve the Purchase of 2,500 gallons of Aluminum Sulfate from Alexander Chemical Corp for a total cost of \$5,522.10
7. Approve the KDI Diving Invoice for a total of \$9,256

D. MAYOR'S REPORT

E. ORDER OF BUSINESS

1. Consideration to Approve Ordinance No. 23-07-18-01, An Ordinance Appropriating for All Corporate Purposes for the City of Wilmington for the Fiscal Year Beginning May 1, 2023 and Ending April 30, 2024
2. Consideration to Approve and Authorize the Execution of the Signage Easement Agreement with Kenneth W Frey at 102 S. Water Street
3. Consideration to Approve the Lime Sludge Removal Quote

F. REPORTS AND COMMUNICATION FROM CITY OFFICIALS

City Attorney – Bryan Wellner

City Administrator – Jeannine Smith

Finance Director – Nancy Gross

Public Works Director – James Gretencord

Police Department – Chief Zink

*Posting Date:
7/14/2023 2:24 PM jz*

G. ALDERMEN COMMENTS

Alderman Kirwin	Alderman Vice	Alderman Allred	Alderman Holmes
Alderman Jeffries	Alderman Knight	Alderman Mietzner	Alderman Smith

H. EXECUTIVE SESSION

1. Appointment, Employment, Dismissal, Compensation, Discipline and Performance of an Employee of the City of Wilmington [ILCS 120/2(c)(1)]
2. Collective negotiating matters between the City of Wilmington (public body) and its employees [ILCS 120/2(c)(2)]
3. Matters of Land Acquisition [ILCS 2(c)(5) and 2(c)(6)]
4. Probable or Imminent Litigation and Pending Litigation [ILCS 2(c)(11)]

I. POSSIBLE ACTION OF EXECUTIVE SESSION ITEMS

J. ADJOURNMENT

This public body may adjourn to a closed session to discuss matters so permitted and may act upon such matters returning to the open session.

So that all may concentrate on the proceedings, please silence cell phones during City Council meetings.

The next regularly scheduled City Council meeting is August 1, 2023.

**MINUTES OF THE REGULAR MEETING OF THE WILMINGTON CITY COUNCIL
JULY 5, 2023**

MAYOR BEN DIETZ CALLED TO ORDER THE REGULAR MEETING OF THE WILMINGTON CITY COUNCIL AT 7:00 P.M.

ROLL CALL

After the pledge of allegiance, the following answered to Roll Call: Alderpersons Kevin Kirwin, Ryan Jeffries, Dennis Vice, Ryan Knight, Leslie Allred, Jonathan Mietzner, and Thomas Smith. Absent: Todd Holmes. The number present constitutes a quorum.

Also present: City Administrator Jeannine Smith (via Zoom), Finance Director Nancy Gross, Chief Adam Zink, Public Works Director James Gretencord, City Attorney Bryan Wellner, and Deputy City Clerk Joie Ziller.

CITIZENS COMMENT

No comments were made.

CONSENT AGENDA

1. Approval of the Regular Meeting Minutes June 20, 2023
2. Approval of the Accounts Payable Report

Alderperson Kirwin made a motion and Alderperson Jeffries seconded to approve the Consent Agenda for the June 20, 2023 City Council meeting as presented

Upon roll call, the vote was:

AYES: 7 Kirwin, Jeffries, Knight, Mietzner, Allred, Smith, Vice

NAYS: 0

ABSENT: 1 Holmes

The motion carried.

MAYOR'S REPORT

Mayor Dietz thanked all the volunteers who came out and helped with the Let Freedom Rock Celebration and thanked the Steering Committee for putting this event together. Mayor Dietz provided an update on the MFT streets project.

ORDER OF BUSINESS

Alderperson Mietzner made a motion and Alderperson Smith seconded to approve the annual salary increase for Deputy Chief of Police Justin Dole to \$108,000, retroactive to June 20, 2023

Upon roll call, the vote was:

AYES: 7 Mietzner, Smith, Jeffries, Vice, Kirwin, Knight, Allred

NAYS: 0

ABSENT: 1 Holmes

The motion carried.

Alderperson Vice made a motion and Alderperson Allred seconded to approve the Intergovernmental Agreement with Intergovernmental Law Enforcement Officer In-Service Training Act Public Act 82-674

Upon roll call, the vote was:

AYES: 7 Vice, Allred, Mietzner, Smith, Jeffries, Kirwin, Knight

NAYS: 0

ABSENT: 1 Holmes

The motion carried.

REPORTS AND COMMUNICATION FROM CITY OFFICIALS

City Attorney – Bryan Wellner – No Report

City Administrator – Jeannine Smith – No Report.

Finance Director – Nancy Gross – No Report

Public Works Director – James Gretencord – Informed the Council that he will be on vacation next week and will be absent for the July Committee of the Whole meeting.

Chief of Police Department – Adam Zink – No Report

ALDERPERSON COMMENTS

Aldersperson Kirwin – No Comment

Aldersperson Vice – No Comment

Aldersperson Allred – No Comment

Aldersperson Holmes – Absent

Aldersperson Jeffries – No Comment

Aldersperson Knight – No Comment

Aldersperson Mietzner – No Comment

Aldersperson Smith – No Comment

EXECUTIVE SESSION

Aldersperson Allred made a motion and Aldersperson Holmes seconded to go into Executive Session at 7:05 PM to discuss Probable or Imminent Litigation and Pending Litigation [ILCS 2(c)(11)] and Collective negotiating matters between the City of Wilmington (public body) and its employees [ILCS 120/2(c)(2)]

Upon roll call, the vote was:

AYES: 7 Allred, Mietzner, Knight, Kirwin, Jeffries, Smith, Vice

NAYS: 0

ABSENT: 1 Holmes

The motion carried.

Aldersperson Allred made a motion and Aldersperson Mietzner seconded to close Executive Session at 7:15 PM

Upon roll call, the vote was:

AYES: 7 Allred, Mietzner, Kirwin, Jeffries, Smith, Vice, Knight

NAYS: 0

ABSENT: 1 Holmes

The motion carried.

POSSIBLE ACTION OF EXECUTIVE SESSION ITEMS

No action taken

ADJOURNMENT

The motion to adjourn the meeting was made by Alderperson Knight and seconded by Alderperson Allred. Upon the voice vote, the motion carried. The City of Wilmington City Council's regular meeting on July 5, 2023, adjourned at 7:16 p.m.

Respectfully submitted,

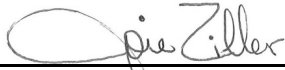
A handwritten signature in cursive script that reads "Joie Ziller". The signature is written in black ink and is positioned above a horizontal line.

Joie Ziller, Deputy City Clerk

Bills to be presented to the City of Wilmington Council on
July 18, 2023

GENERAL FUND

01 ADMINISTRATION	\$2,831.43
02 BUILDINGS & GROUNDS	3,007.01
03 POLICE	6,413.68
04 POLICE COMMISSION BOARD	0.00
05 PUBLIC WORKS	2,242.76
09 PAYROLL TAXES/PENSION	0.00
10 AUDIT & ACCOUNTING	0.00
13 BUILDING	450.00
14 PLANNING & ZONING	0.00
15 POLICE PENSION	0.00
21 ECONOMIC DEVELOPMENT	0.00
22 COMMUNITY FESTIVALS (not CFDs)	1,481.00
25 GENERAL LIABILITY	8,206.17
CATFISH DAYS	18,949.51
ESDA FUND	412.40
MOBILE EQUIPMENT FUND	0.00
TOTAL TO BE PAID FROM GENERAL FUND	\$43,993.96

WATER/SEWER

WATER OPERATIONS	\$11,979.06
WATER CAPITAL	478.89
GARBAGE SERVICE	0.00
SEWER OPERATIONS	33,580.92
SEWER CAPITAL	0.00
TOTAL TO BE PAID FROM WATER/SEWER	\$46,038.87

DFC FEDERAL GRANT FUND

\$0.00

CAPITAL PROJECTS

\$0.00

DEBT SERVICE

\$0.00

RIDGEPORT TIF #2

\$0.00

DEVELOPER DISBURSEMENTS

0.00

TOTAL TO BE PAID FROM TIF #2

\$0.00

PAYROLL

PAY DATE 07/14/2023 \$126,049.49

TOTAL PAYROLL **\$126,049.49**

TOTAL BILLS TO BE PAID **\$216,082.32**

These checks here listed have been approved and ordered paid at the
meeting of the City of Wilmington Council on the 18th of July 2023.

Dennis Vice

Kevin Kirwin

Ryan Jeffries

Leslie Allred

Jonathan Mietzner

Thomas Smith

Ryan Knight

Todd Holmes

Accounts Payable

GL Distribution Report

User: Msurman
 Printed: 7/18/2023 - 2:37 PM
 Batch: 00007.07.2023
 Fiscal Period: 3
 JE Date: 7/18/2023 12:00:00 AM

FUND

01 General Corporate Fund

DR Amount CR Amount Account Number Description

0.00	18,913.00	01-00-3202	Accounts Payable
3,500.00	0.00	01-20-7156	MISC CATFISH DAYS EXPENSES
1,300.00	0.00	01-20-7156	MISC CATFISH DAYS EXPENSES
3,250.00	0.00	01-20-7156	MISC CATFISH DAYS EXPENSES
400.00	0.00	01-20-7156	MISC CATFISH DAYS EXPENSES
300.00	0.00	01-20-7156	MISC CATFISH DAYS EXPENSES
3,088.00	0.00	01-20-7156	MISC CATFISH DAYS EXPENSES
500.00	0.00	01-20-7156	MISC CATFISH DAYS EXPENSES
350.00	0.00	01-20-7156	MISC CATFISH DAYS EXPENSES
825.00	0.00	01-20-7156	MISC CATFISH DAYS EXPENSES
1,500.00	0.00	01-20-7156	MISC CATFISH DAYS EXPENSES
650.00	0.00	01-20-7156	MISC CATFISH DAYS EXPENSES
3,250.00	0.00	01-20-7156	MISC CATFISH DAYS EXPENSES
18,913.00	18,913.00		

Grand Total:

18,913.00	18,913.00		
-----------	-----------	--	--



City of Wilmington
 1165 S. Water St
 Wilmington, IL 60481
 815-476-2175

Accounts Payable

To Be Paid Proof List

User: Msurman
 Printed: 07/18/2023 - 2:37PM
 Batch: 00007.07.2023

City of Wilmington
 1165 S. Water St
 Wilmington, IL 60481
 815-476-2175



Invoice Number	Account Number	Invoice Date	Amount	Quantity	Payment Date	Task Label	Type	PO #	Close PO	Line #
					Description		Reference			
Bizness, Inc. 108760		7/14/2023	1,300.00	0.00	07/18/2023					0
	CFD2023 7/23/23									
	01-20-7156 MISC CATFISH DAYS EXPENSES				Band CFD2023 7/23/2023	Greg's Fender Benders				
		CFD2023 7/23/23 Total:	1,300.00							
		Bizness, Inc. Total:	1,300.00							
Centerline, Inc. 108761		7/14/2023	3,500.00	0.00	07/18/2023					0
	CFD2023 7/21/23									
	01-20-7156 MISC CATFISH DAYS EXPENSES				CFD2023 Band 7/23/2023					
		CFD2023 7/21/23 Total:	3,500.00							
		Centerline, Inc. Total:	3,500.00							
Emling, Rodney 1851		7/11/2023	825.00	0.00	07/18/2023					0
	Final CFD2023									
	01-20-7156 MISC CATFISH DAYS EXPENSES				Balance Stage Rental	CFD2023				
		Final CFD2023 Total:	825.00							
		Emling, Rodney Total:	825.00							

AP-To Be Paid Proof List (07/18/2023 - 2:37 PM)
 *** means this invoice number is a duplicate.

Invoice Number	Invoice Date	Amount	Quantity	Payment Date	Task Label	Type	PO #	Close PO	Line #
Account Number				Description		Reference			
Gregorich, Roy 108618	7/14/2023	650.00	0.00	07/18/2023				No	0
CFD2023 DJ				July 20,22,23 - 2023 CFD2023 DJ work					
01-20-7156 MISC CATFISH DAYS EXPENSES									
	CFD2023 DJ Total:	650.00							
	Gregorich, Roy Total:	650.00							
Hunt, Robert 1743	7/11/2023	350.00	0.00	07/18/2023				No	0
CFD2023				CFD2023 Circus Boy					
01-20-7156 MISC CATFISH DAYS EXPENSES									
	CFD2023 Total:	350.00							
	Hunt, Robert Total:	350.00							
Kozol Brothers 0252	7/18/2023	3,088.00	0.00	07/18/2023				No	0
1917840				Alcohol - CFD2023					
01-20-7156 MISC CATFISH DAYS EXPENSES									
	1917840 Total:	3,088.00							
1917841	7/18/2023	500.00	0.00	07/18/2023				No	0
01-20-7156 MISC CATFISH DAYS EXPENSES				Wagon Deposit for Alcohol - CFD2023					
	1917841 Total:	500.00							
	Kozol Brothers Total:	3,588.00							
Langenderfer, Colin 108757	7/11/2023	400.00	0.00	07/18/2023				No	0
ReptileShow				Reptile Show 7/21/23 CFD2023					
01-20-7156 MISC CATFISH DAYS EXPENSES									

Invoice Number	Account Number	Invoice Date	Amount	Quantity	Payment Date	Task Label	Type	PO #	Close PO	Line #
		Description								
		ReptileShow Total:	400.00							
		Langenderfer, Colin Total:	400.00							
Laser Encore	1734	7/11/2023	3,250.00	0.00	07/18/2023	Balance CFD 2023 Laser Show			No	0
		BalanceCFD23 Total:	3,250.00							
DepositCFD23		7/11/2023	3,250.00	0.00	07/18/2023	Down Payment CFD 2023 Laser Show			No	0
		DepositCFD23 Total:	3,250.00							
		Laser Encore Total:	6,500.00							
LAWRENCE, MARK	108525	7/11/2023	1,500.00	0.00	07/18/2023	CFD2023 Band 7/22/23			No	0
		CFD23 Band Total:	1,500.00							
		LAWRENCE, MARK Total:	1,500.00							
Petty Cash Fund	0331	7/14/2023	300.00	0.00	07/18/2023	Start Up Funds			No	0
		Start Up Funds Total:	300.00							
		Petty Cash Fund Total:	300.00							

AP-To Be Paid Proof List (07/18/2023 - 2:37 PM)
 *** means this invoice number is a duplicate.

Invoice Number **Invoice Date** **Amount** **Quantity** **Payment Date** **Task Label** **Type** **PO #** **Close PO** **Line #**
Account Number

Report Total: 18,913.00

Accounts Payable

GL Distribution Report

User: Msurman
 Printed: 7/18/2023 - 2:54 PM
 Batch: 00100.07.2023
 Fiscal Period: 3
 JE Date: 7/18/2023 12:00:00 AM

FUND

01 General Corporate Fund

DR Amount	CR Amount	Account Number	Description
0.00	24,668.56	01-00-3202	Accounts Payable
714.85	0.00	01-01-6335	Prof Fees - Computer R&M
205.00	0.00	01-01-6380	Employee Health & Life Insurnc
1,431.00	0.00	01-01-6385	Retired Empl Health Ins/Dental
84.00	0.00	01-01-6670	Prof Fees - Other
312.81	0.00	01-01-6760	Telephone/Internet
83.77	0.00	01-01-6970	Oper Supplies and Tools
126.12	0.00	01-02-6530	Maintenance - Grounds/Building
955.93	0.00	01-02-6530	Maintenance - Grounds/Building
1,037.26	0.00	01-02-6530	Maintenance - Grounds/Building
346.41	0.00	01-02-6530	Maintenance - Grounds/Building
427.29	0.00	01-02-6970	Oper Supplies and Tools
114.00	0.00	01-02-6970	Oper Supplies and Tools
1,254.20	0.00	01-03-6335	Prof Fees - Computer R&M
2,120.00	0.00	01-03-6360	Dues Subscrip. & Memberships
525.00	0.00	01-03-6460	Legal Services
265.30	0.00	01-03-6760	Telephone/Internet
230.46	0.00	01-03-6760	Telephone/Internet
1,800.00	0.00	01-03-6970	Oper Supplies and Tools
94.15	0.00	01-03-6970	Oper Supplies and Tools
75.00	0.00	01-03-6970	Oper Supplies and Tools
22.57	0.00	01-03-6970	Oper Supplies and Tools
27.00	0.00	01-03-6970	Oper Supplies and Tools
60.90	0.00	01-05-6335	Oper Supplies and Tools
200.00	0.00	01-05-6380	Prof Fees - Computer R&M
312.81	0.00	01-05-6380	Employee Health & Life Insurnc
74.57	0.00	01-05-6760	Telephone/Internet
129.95	0.00	01-05-6780	Tree and Weed Removal
525.52	0.00	01-05-6780	Tree and Weed Removal
143.21	0.00	01-05-6970	Oper Supplies and Tools
572.90	0.00	01-05-6970	Oper Supplies and Tools



City of Wilmington
 1165 S. Water St
 Wilmington, IL 60481
 815-476-2175

FUND	DR Amount	CR Amount	Account Number	Description
	222.90	0.00	01-05-7010	Uniforms & Accessories
	450.00	0.00	01-13-6337	Consulting Fee
	36.51	0.00	01-20-7156	MISC CATFISH DAYS EXPENSES
	90.00	0.00	01-22-7158	LET FREEDOM ROCK EXPENSES
	90.00	0.00	01-22-7158	LET FREEDOM ROCK EXPENSES
	45.00	0.00	01-22-7158	LET FREEDOM ROCK EXPENSES
	37.50	0.00	01-22-7158	LET FREEDOM ROCK EXPENSES
	90.00	0.00	01-22-7158	LET FREEDOM ROCK EXPENSES
	236.00	0.00	01-22-7158	LET FREEDOM ROCK EXPENSES
	37.50	0.00	01-22-7158	LET FREEDOM ROCK EXPENSES
	37.50	0.00	01-22-7158	LET FREEDOM ROCK EXPENSES
	37.50	0.00	01-22-7158	LET FREEDOM ROCK EXPENSES
	37.50	0.00	01-22-7158	LET FREEDOM ROCK EXPENSES
	37.50	0.00	01-22-7158	LET FREEDOM ROCK EXPENSES
	37.50	0.00	01-22-7158	LET FREEDOM ROCK EXPENSES
	90.00	0.00	01-22-7158	LET FREEDOM ROCK EXPENSES
	90.00	0.00	01-22-7158	LET FREEDOM ROCK EXPENSES
	37.50	0.00	01-22-7158	LET FREEDOM ROCK EXPENSES
	30.00	0.00	01-22-7158	LET FREEDOM ROCK EXPENSES
	120.00	0.00	01-22-7158	LET FREEDOM ROCK EXPENSES
	60.00	0.00	01-22-7158	LET FREEDOM ROCK EXPENSES
	37.50	0.00	01-22-7158	LET FREEDOM ROCK EXPENSES
	150.00	0.00	01-22-7158	LET FREEDOM ROCK EXPENSES
	90.00	0.00	01-22-7158	LET FREEDOM ROCK EXPENSES
	8,206.17	0.00	01-25-6690	W/Comp Ins
	<u>24,668.56</u>	<u>24,668.56</u>		
07 ESDA Fund				
	0.00	412.40	07-00-3202	Accounts Payable
	159.95	0.00	07-00-6640	Maint-Vehicles
	50.75	0.00	07-00-6640	Maint-Vehicles
	33.98	0.00	07-00-6970	Oper Supplies and Tools
	167.72	0.00	07-00-6970	Oper Supplies and Tools
	<u>412.40</u>	<u>412.40</u>		
Grand Total:	<u>25,080.96</u>	<u>25,080.96</u>		

Accounts Payable

To Be Paid Proof List

User: Msurman
 Printed: 07/18/2023 - 2:54PM
 Batch: 00100.07.2023

City of Wilmington
 1165 S. Water St
 Wilmington, IL 60481
 815-476-2175



Invoice Number	Account Number	Invoice Date	Amount	Quantity	Payment Date	Task Label	Type	PO #	Close PO	Line #
					Description		Reference			
Air Gas USA, LLC	9050	7/14/2023	143.21	0.00	07/18/2023					0
5500176102			143.21		Cyl Rental					
01-05-6970 Oper Supplies and Tools										
5500176102 Total:			143.21							
Air Gas USA, LLC Total:			143.21							
Alarm Detection Systems, Inc.	9048	7/12/2023	126.12	0.00	07/18/2023					0
108342-1056			126.12		Jul-Sept. 2023 Qlty charges					
01-02-6530 Maintenance - Grounds/Building										
108342-1056 Total:			126.12							
Alarm Detection Systems, Inc.	208363-1056	7/12/2023	346.41	0.00	07/18/2023					0
01-02-6530 Maintenance - Grounds/Building			346.41		Jul-Sept. 2023 Qlty charges					
208363-1056 Total:			346.41							
Alarm Detection Systems,			472.53							
AT&T	0030	7/14/2023	312.81	0.00	07/18/2023					0
*** 815476977307			312.81		07/04/2023 - 08/03/2023					
01-05-6760 Telephone/Internet										

AP-To Be Paid Proof List (07/18/2023 - 2:54 PM)

*** means this invoice number is a duplicate.

Invoice Number	Invoice Date	Amount	Quantity	Payment Date	Task Label	Type	PO #	Close PO	Line #
Account Number	Description					Reference			
	815476977307 Total:	312.81							
815476978207	7/14/2023	312.81	0.00	07/18/2023				No	0
	01-01-6760 Telephone/Internet			07/04/2023 - 08/03/2023					
	815476978207 Total:	312.81							
	AT&T Total:	625.62							
	B & F Construction Code Services, Inc.								
108584									
62070	7/14/2023	450.00	0.00	07/18/2023				No	0
	01-13-6337 Consulting Fee				Primesource-30350 S. Graaskamp Racking Plan Review				
	62070 Total:	450.00							
	B & F Construction Code S	450.00							
	Blue Cross Blue Shield of Illinois								
9103									
Aug. 2023	7/12/2023	1,431.00	0.00	07/18/2023				No	0
	01-01-6385 Retired Empl Health Ins/Dental				Aug. 2023 statement				
	Aug. 2023 Total:	1,431.00							
	Blue Cross Blue Shield of	1,431.00							
	BTT Tire & Alignment								
1789									
31442	7/12/2023	159.95	0.00	07/18/2023				No	0
	07-00-6640 Maint-Vehicles				battery				
	31442 Total:	159.95							
	BTT Tire & Alignment Tota	159.95							

Invoice Number	Account Number	Invoice Date	Amount	Quantity	Payment Date	Task Label	Type	PO #	Close PO	Line #
Account Number		Description								
Cintas First Aid & Safety 1497										
5165830344		7/14/2023	83.77	0.00	07/18/2023					
01-01-6970 Oper Supplies and Tools					First Aid Supplies				No	0
	5165830344 Total:		83.77							
	Cintas First Aid & Safety T		83.77							
Comcast 9059										
*** 8771200210101:		7/12/2023	230.46	0.00	07/18/2023					
01-03-6760 Telephone/Internet					7/5/23 - 8/4/23				No	0
	877120021010180 Total:		230.46							
	Comcast Total:		230.46							
DTW Inc 0117										
8916a		7/11/2023	714.85	0.00	07/18/2023					
01-01-6335 Prof Fees - Computer R&M					June 2023 Statement				No	0
	8916a Total:		714.85							
8916b		7/11/2023	60.90	0.00	07/18/2023					
01-05-6335 Prof Fees - Computer R&M					June 2023 Statement				No	0
	8916b Total:		60.90							
8933		7/11/2023	1,254.20	0.00	07/18/2023					
01-03-6335 Prof Fees - Computer R&M					June 2023 Statement				No	0
	8933 Total:		1,254.20							
	DTW Inc Total:		2,029.95							

AP-To Be Paid Proof List (07/18/2023 - 2:54 PM)
 *** means this invoice number is a duplicate.

Invoice Number	Invoice Date	Amount	Quantity	Payment Date	Task Label	Type	PO #	Close PO	Line #
Account Number	Description			Description		Reference			
G W Communications 0144	7/11/2023	236.00	0.00	07/18/2023				No	0
00023368	01-22-7158 LET FREEDOM ROCK EXPENSES			Let Freedom Rock Ad					
	00023368 Total:	236.00							
	G W Communications Total	236.00							
Gotte, Kimberly 1813	7/12/2023	90.00	0.00	07/18/2023				No	0
6/30/23 Event	01-22-7158 LET FREEDOM ROCK EXPENSES			Let Freedom Rock 6/30/23 Event 6 hours					
	6/30/23 Event Total:	90.00							
	Gotte, Kimberly Total:	90.00							
Hiskes, Dillner, O'Donnell, Marovich & Lapp, LTD 108570	7/12/2023	525.00	0.00	07/18/2023				No	0
18631	01-03-6460 Legal Services			June 2023 Adj. Court					
	18631 Total:	525.00							
	Hiskes, Dillner, O'Donnell	525.00							
Hodolitz, Paul 1609	7/12/2023	45.00	0.00	07/18/2023				No	0
6/30/23 Event	01-22-7158 LET FREEDOM ROCK EXPENSES			Let Freedom Rock Event 6/30/23 3 hours					
	6/30/23 Event Total:	45.00							

Invoice Number	Account Number	Invoice Date	Amount	Quantity	Payment Date	Task Label	Type	PO #	Close PO	Line #
		Description					Reference			
Housman, Dennis		Hodolitz, Paul Total:	45.00							
0108										
06/30/23 LFR		7/12/2023	150.00	0.00	07/18/2023				No	0
		01-22-7158 LET FREEDOM ROCK EXPENSES				Let Freedom Rock 6/30/23 Event 10 hours				
		06/30/23 LFR Total:	150.00							
07/1/23 cleanup		7/12/2023	37.50	0.00	07/18/2023				No	0
		01-22-7158 LET FREEDOM ROCK EXPENSES				Let Freedom Rock 7/1/23 Clean UP 2.5 hours				
		07/1/23 cleanup Total:	37.50							
6/29/23 setup		7/12/2023	120.00	0.00	07/18/2023				No	0
		01-22-7158 LET FREEDOM ROCK EXPENSES				Let Freedom Rock 6/29/23 set up 8 hours				
		6/29/23 setup Total:	120.00							
		Housman, Dennis Total:	307.50							
Illinois Public Risk Fund										
9125										
82777a		7/12/2023	8,206.17	0.00	07/18/2023				No	0
		01-25-6690 W/Comp Ins				Aug. 2023 WC				
		82777a Total:	8,206.17							
Illinois Public Risk Fund T										
			8,206.17							
Krohn, Sarah										
1769										
6/29/23 Set Up		7/12/2023	37.50	0.00	07/18/2023				No	0
		01-22-7158 LET FREEDOM ROCK EXPENSES				Let Freedom Rock 6/29/23 Set Up 2.5 hours				
		6/29/23 Set Up Total:	37.50							

AP-To Be Paid Proof List (07/18/2023 - 2:54 PM)
 *** means this invoice number is a duplicate.

Invoice Number	Invoice Date	Amount	Quantity	Payment Date	Task Label	Type	PO #	Close PO	Line #
Account Number	Description					Reference			
6/30/23 Event	7/12/2023	90.00 *	0.00	07/18/2023				No	0
01-22-7158 LET FREEDOM ROCK EXPENSES				Let Freedom Rock 6/30/23 Event 6 hours					
	6/30/23 Event Total:	90.00							
	Krohn, Sarah Total:	127.50							
Lardi, Barbara									
1844									
6/30/23 Event	7/12/2023	90.00 ✓	0.00	07/18/2023				No	0
01-22-7158 LET FREEDOM ROCK EXPENSES				Let Freedom Rock Event 6/30/23 6 hours					
	6/30/23 Event Total:	90.00							
7/1/23 Clean Up	7/12/2023	37.50	0.00	07/18/2023				No	0
01-22-7158 LET FREEDOM ROCK EXPENSES				Let Freedom Rock Clean Up 7/1/23 2.5 hours					
	7/1/23 Clean Up Total:	37.50 ✓							
	Lardi, Barbara Total:	127.50							
Lucky, Andrew									
1170									
6/29/23 Set Up	7/12/2023	37.50 ✓	0.00	07/18/2023				No	0
01-22-7158 LET FREEDOM ROCK EXPENSES				Let Freedom Rock 6/29/23 set up 2.5 hours					
	6/29/23 Set Up Total:	37.50							
	Lucky, Andrew Total:	37.50							
Luhrsen, Steven									
1396									
6/30/23 Events	7/12/2023	90.00 ✓	0.00	07/18/2023				No	0
01-22-7158 LET FREEDOM ROCK EXPENSES				Let Freedom Rock Event 6/30/23 6 hours					
	6/30/23 Events Total:	90.00							

Invoice Number	Invoice Date	Amount	Quantity	Payment Date	Task Label	Type	PO #	Close PO	Line #
Account Number	Description			Description		Reference			
7/1/23 CleanUp	7/12/2023	37.50	0.00	07/18/2023				No	0
01-22-7158 LET FREEDOM ROCK EXPENSES				Let Freedom Rock Clean Up 7/1/23 2.5 hours					
	7/1/23 CleanUp Total:	37.50							
	Luhrsen, Steven Total:	127.50							
McKanna, Patrick 108585	7/12/2023	30.00	0.00	07/18/2023				No	0
6/29/23 Set Up				Let Freedom Rock 6/29/23 Set Up 2 hours					
01-22-7158 LET FREEDOM ROCK EXPENSES									
	6/29/23 Set Up Total:	30.00							
6/30/23 Event	7/12/2023	60.00	0.00	07/18/2023				No	0
01-22-7158 LET FREEDOM ROCK EXPENSES				Let Freedom Rock 6/30/23 Event 4 hours					
	6/30/23 Event Total:	60.00							
	McKanna, Patrick Total:	90.00							
Menards Bradley 0280	7/18/2023	427.29	0.00	07/18/2023				No	0
Reissue75921				Reissue - Cafe Azul, Flatlok, Bar Sink					
01-02-6970 Oper Supplies and Tools									
	Reissue75921 Total:	427.29							
	Menards Bradley Total:	427.29							
Primary Care Physicians of Joliet, SC 0344	7/11/2023	205.00	0.00	07/18/2023				No	0
E.Swick				Ella Swick new employee physical/drug screen					
01-01-6380 Employee Health & Life Insurnc									
	E.Swick Total:	205.00							

AP-To Be Paid Proof List (07/18/2023 - 2:54 PM)
 *** means this invoice number is a duplicate.

Invoice Number	Invoice Date	Amount	Quantity	Payment Date	Task Label	Type	PO #	Close PO	Line #
Account Number	Description					Reference			
Primary Care Physicians of		205.00							
Princko, Richard									
0362	7/12/2023	37.50 ✓	0.00	07/18/2023				No	0
6/29/23 setup	01-22-7158 LET FREEDOM ROCK EXPENSES				Let Freedom Rock set up 2.5 hours 6/29/23				
	6/29/23 setup Total:	37.50							
6/30/23 Event	7/12/2023	90.00	0.00	07/18/2023				No	0
01-22-7158 LET FREEDOM ROCK EXPENSES	01-22-7158 LET FREEDOM ROCK EXPENSES				Let Freedom Rock Event 6 hours 6/30/23				
	6/30/23 Event Total:	90.00 ✓							
Princko, Richard Total:		127.50							
Ray O Herron Inc									
0358	7/11/2023	1,800.00 ✓	0.00	07/18/2023				No	0
2267968	20 - NS ORG FRT GK Gen5								
01-03-6970 Oper Supplies and Tools									
	2267968 Total:	1,800.00							
Ray O Herron Inc Total:		1,800.00							
Riverside WorkForce Health									
0365	7/12/2023	200.00 ✓	0.00	07/18/2023				No	0
00113615-00	01-05-6380 Employee Health & Life Insurnc				Michael Busby DOT Physical & Drug Screen				
	00113615-00 Total:	200.00 ✓							
Riverside WorkForce Health		200.00							

TA Operating, LLC

Invoice Number	Account Number	Invoice Date	Amount	Quantity	Payment Date	Task Label	Type	PO #	Close PO	Line #
		Description								
1513										
1114		7/11/2023	27.00	0.00	07/18/2023				No	0
	01-03-6970 Oper Supplies and Tools				Scales - 6/29/23, 6/30/23					
	1114 Total:		27.00 ✓							
	TA Operating, LLC Total:		27.00							
	TransUnionsRisk&Alternative Data Solutions, Inc.									
1247										
264981-202306-1		7/12/2023	75.00	0.00	07/18/2023				No	0
	01-03-6970 Oper Supplies and Tools				June 2023					
	264981-202306-1 Total:		75.00							
	TransUnionsRisk&Alterna									
	TransUnionsRisk&Alterna		75.00 ✓							
	Tri River Police Training Reg									
0440										
5270		7/12/2023	2,120.00 ✓	0.00	07/18/2023				No	0
	01-03-6360 Dues Subscrip. & Memberships				FY24 Membership Dues Full & Part time					
	5270 Total:		2,120.00							
	Tri River Police Training R									
	Tri River Police Training R		2,120.00							
	Verizon Connect									
1885										
607000044639		7/11/2023	265.30	0.00	07/18/2023				No	0
	01-03-6760 Telephone/Internet				06/01/23 - 06/30/2023					
	607000044639 Total:		265.30 ✓							
	Verizon Connect Total:		265.30							

AP-To Be Paid Proof List (07/18/2023 - 2:54 PM)
 *** means this invoice number is a duplicate.

Invoice Number	Invoice Date	Amount	Quantity	Payment Date	Task Label	Type	PO #	Close PO	Line #
Account Number	Description			Description		Reference			
Ward, Erin 1770	7/12/2023	37.50 /	0.00	07/18/2023				No	0
01-22-7158 LET FREEDOM ROCK EXPENSES				Let Freedom Rock Set Up 6/29/23					
6/29/23 Setup Total:		37.50							
6/30/23 Event	7/12/2023	90.00	0.00	07/18/2023				No	0
01-22-7158 LET FREEDOM ROCK EXPENSES				Let Freedom Rock Event 06/30/23					
6/30/23 Event Total:		90.00 /							
7/1/23 CleanUP	7/12/2023	37.50	0.00	07/18/2023				No	0
01-22-7158 LET FREEDOM ROCK EXPENSES				Let Freedom Rock Clean Up 07/1/23					
7/1/23 CleanUP Total:		37.50 /							
Ward, Erin Total:		165.00							
Whitmore Investments Inc 0472	7/18/2023	167.72	0.00	07/18/2023				No	0
June2023a				June 2023 Statement					
07-00-6970 Oper Supplies and Tools									
June2023a Total:		167.72							
June2023b	7/18/2023	50.75	0.00	07/18/2023				No	0
07-00-6640 Maint-Vehicles				June 2023 Statement					
June2023b Total:		50.75							
June2023c	7/18/2023	1,037.26	0.00	07/18/2023				No	0
01-02-6530 Maintenance - Grounds/Building				June 2023 Statement					
June2023c Total:		1,037.26							
June2023d	7/18/2023	36.51	0.00	07/18/2023				No	0
01-20-7156 MISC CATFISH DAYS EXPENSES				June 2023 Statement					
June2023d Total:		36.51							

Invoice Number	Invoice Date	Amount	Quantity	Payment Date	Task Label	Type	PO #	Close PO	Line #
Account Number	Description			Description		Reference			
June2023e	7/18/2023	94.15	0.00	07/18/2023				No	0
01-03-6970 Oper Supplies and Tools				June 2023 Statement					
	June2023e Total:	94.15							
June2023f	7/18/2023	222.90	0.00	07/18/2023				No	0
01-05-7010 Uniforms & Accessories				June 2023 Statement					
	June2023f Total:	222.90							
June2023g	7/18/2023	129.95	0.00	07/18/2023				No	0
01-05-6780 Tree and Weed Removal				June 2023 Statement					
	June2023g Total:	129.95							
June2023h	7/18/2023	572.90	0.00	07/18/2023				No	0
01-05-6970 Oper Supplies and Tools				June 2023 Statement					
	June2023h Total:	572.90							
May2023a	7/18/2023	33.98	0.00	07/18/2023				No	0
07-00-6970 Oper Supplies and Tools				May 2023 Statement					
	May2023a Total:	33.98							
May2023b	7/18/2023	955.93	0.00	07/18/2023				No	0
01-02-6530 Maintenance - Grounds/Building				May 2023 Statement					
	May2023b Total:	955.93							
May2023c	7/18/2023	525.52	0.00	07/18/2023				No	0
01-05-6970 Oper Supplies and Tools				May 2023 Statement					
	May2023c Total:	525.52							
May2023d	7/18/2023	74.57	0.00	07/18/2023				No	0
01-05-6780 Tree and Weed Removal				May 2023 Statement					
	May2023d Total:	74.57							
May2023e	7/18/2023	22.57	0.00	07/18/2023				No	0
01-03-6970 Oper Supplies and Tools				May 2023 Statement					

AP- To Be Paid Proof List (07/18/2023 - 2:54 PM)
 *** means this invoice number is a duplicate.

Invoice Number	Invoice Date	Amount	Quantity	Payment Date	Task Label	Type	PO #	Close PO	Line #
Account Number				Description		Reference			
	May2023e Total:	22.57							
	Whitmore Investments Inc	3,924.71							
Will County Recorder 0481	7/12/2023	84.00	0.00	07/18/2023					0
40705795				Municipal Lien					
01-01-6670 Prof Fees - Other									
	40705795 Total:	84.00							
	Will County Recorder Total	84.00							
Wilmington Overhead Door Co. 0494	7/11/2023	114.00	0.00	07/18/2023					0
098470				893 Max Transmitters					
01-02-6970 Oper Supplies and Tools									
	098470 Total:	114.00							
	Wilmington Overhead Door	114.00							
	Report Total:	25,080.96							

Accounts Payable

GL Distribution Report

User: Msurman
 Printed: 7/18/2023 - 2:18 PM
 Batch: 00200.07.2023
 Fiscal Period: 3
 JE Date: 7/18/2023 12:00:00 AM

FUND

02 Water Fund

DR Amount	CR Amount	Account Number	Description
0.00	12,457.95	02-00-3202	Accounts Payable
478.89	0.00	02-17-6620	Maint - Water Meters
279.81	0.00	02-21-6335	Prof Fees - Computer R&M
877.50	0.00	02-21-6510	Maintenance - Equipment
2,000.00	0.00	02-21-6510	Maintenance - Equipment
295.98	0.00	02-21-6530	Maintenance - Site Grnds/Bldg
16.59	0.00	02-21-6530	Maintenance - Site Grnds/Bldg
199.11	0.00	02-21-6530	Maintenance - Site Grnds/Bldg
74.54	0.00	02-21-6540	Maintenance - Site Grnds/Bldg
834.31	0.00	02-21-6610	Maint-Distribution
1,644.32	0.00	02-21-6690	Maint-Site Process Mains
4,235.11	0.00	02-21-6810	W/Comp Ins
661.32	0.00	02-21-6970	Utilities
385.23	0.00	02-21-6970	Oper Supplies and Tools
109.99	0.00	02-21-6970	Oper Supplies and Tools
333.40	0.00	02-21-7030	Uniforms & Accessories
31.85	0.00	02-21-7030	Water Treatment Chemicals
		02-21-7030	Water Treatment Chemicals
12,457.95	12,457.95		

04 Sewer Fund

0.00	33,580.92	04-00-3202	Accounts Payable
69.92	0.00	04-00-6560	Maintenance Sewers Collection
53.95	0.00	04-00-6560	Maintenance Sewers Collection
15,000.00	0.00	04-00-6671	Testing & Calibration
1,488.51	0.00	04-00-6690	W/Comp Ins
64.90	0.00	04-00-6760	Telephone/Internet
7,658.44	0.00	04-00-6810	Utilities - Electric & Gas
120.12	0.00	04-00-6970	Oper Supplies & Tool
307.47	0.00	04-00-6970	Oper Supplies & Tool
325.51	0.00	04-00-6970	Oper Supplies & Tool
12,457.95	12,457.95		



City of Wilmington
 1165 S. Water St
 Wilmington, IL 60481
 815-476-2175

FUND	DR Amount	CR Amount	Account Number	Description
	5,522.10	0.00	04-00-6985	Sewer Chemicals
	2,970.00	0.00	04-00-6985	Sewer Chemicals
	<u>33,580.92</u>	<u>33,580.92</u>		
	<u>46,038.87</u>	<u>46,038.87</u>		
Grand Total:				

Accounts Payable

To Be Paid Proof List

User: Msurman
 Printed: 07/18/2023 - 2:18PM
 Batch: 00200.07.2023

City of Wilmington
 1165 S. Water St
 Wilmington, IL 60481
 815-476-2175



Invoice Number	Account Number	Invoice Date	Amount	Quantity	Payment Date	Task Label	Type	PO #	Close PO	Line #
					Description		Reference			
Alarm Detection Systems, Inc. 9048										
153679-1027		7/13/2023	295.98	0.00	07/18/2023				No	0
02-21-6530 Maintenance - Site Grmds/Bldg					July - Sept. 2023 Qtrly Charges					
153679-1027 Total:			295.98							
208364-1057		7/13/2023	199.11	0.00	07/18/2023				No	0
02-21-6530 Maintenance - Site Grmds/Bldg					July - Sept. 2023 Qtrly Charges					
208364-1057 Total:			199.11							
Alarm Detection Systems,			495.09							
Alexander Chemical Corporation 0009										
69504		7/13/2023	5,522.10	0.00	07/18/2023				No	0
04-00-6985 Sewer Chemicals					Aluminum Sulfate Liquid					
69504 Total:			5,522.10							
Alexander Chemical Corpo			5,522.10							
Dynegy Energy Services 1655										
274486723061		7/13/2023	4,235.11	0.00	07/18/2023				No	0
02-21-6810 Utilities					June 2023 Statement					

AP-To Be Paid Proof List (07/18/2023 - 2:18 PM)

*** means this invoice number is a duplicate.

Invoice Number	Invoice Date	Amount	Quantity	Payment Date	Task Label	Type	PO #	Close PO	Line #
Account Number	Description					Reference			
	274486723061 Total:	4,235.11							
274486723061s	7/13/2023	7,658.44 *	0.00	07/18/2023				No	0
04-00-6810 Utilities - Electric & Gas				June 2023 Statement					
	274486723061s Total:	7,658.44							
	Dydegy Energy Services To	11,893.55							
Illinois Environmental Protection Agency									
9101									
*** IL0026085(A)	7/13/2023	15,000.00 *	0.00	07/18/2023				No	0
04-00-6671 Testing & Calibration				July 1, 2023 - June 30, 2024 Annual NPDES Fee					
	IL0026085(A) Total:	15,000.00							
Illinois Environmental Prote		15,000.00							
Illinois Public Risk Fund									
9125									
82777s	7/13/2023	1,488.51 *	0.00	07/18/2023				No	0
04-00-6690 W/Comp Ins				Aug. 2023					
	82777s Total:	1,488.51							
82777w	7/13/2023	1,644.32 *	0.00	07/18/2023				No	0
02-21-6690 W/Comp Ins				Aug. 2023					
	82777w Total:	1,644.32							
Illinois Public Risk Fund T		3,132.83							
Intwine Connect, LLC									
108501									
4332	7/13/2023	64.90 ✓	0.00	07/18/2023				No	0
04-00-6760 Telephone/Internet				July 2023 POTS in a box					

Invoice Number	Account Number	Invoice Date	Amount	Quantity	Payment Date	Task Label	Type	PO #	Close PO	Line #
		Description					Reference			
	4332 Total:		64.90							
	Intwine Connect, LLC Tota		64.90							
	Mechanical Plumbing & Heating, Inc.									
	108719									
	887-23-34	7/13/2023	2,000.00 ✓	0.00	07/18/2023				No	0
	02-21-6510 Maintenance - Equipment						Assist in pump& motor change out June 2023			
	887-23-34 Total:		2,000.00							
	Mechanical Plumbing & H		2,000.00							
	Menards Bradley									
	0280									
	78759	7/13/2023	279.81 ✓	0.00	07/18/2023				No	0
	02-21-6335 Prof Fees - Computer R&M						Cat5E cable, HD tool, connectors			
	78759 Total:		279.81							
	Menards Bradley Total:		279.81							
	Metropolitan Industries Inc									
	0283									
	INV051661	7/13/2023	877.50	0.00	07/18/2023				No	0
	02-21-6510 Maintenance - Equipment						Booster Station/Arsenal Rd. Service			
	INV051661 Total:		877.50 ✓							
	Metropolitan Industries Inc		877.50							
	Nestle Water North America									
	1439									
	23F8103700285	7/12/2023	120.12 ✓	0.00	07/18/2023				No	0

AP-To Be Paid Proof List (07/18/2023 - 2:18 PM)

*** means this invoice number is a duplicate.

Invoice Number	Invoice Date	Amount	Quantity	Payment Date	Task Label	Type	PO #	Close PO	Line #
Account Number	Description					Reference			
04-00-6970 Oper Supplies & Tool									
	23F8103700285 Total:	120.12			Drinking water/cooler rental				
	Nestle Water North Americ	120.12							
Polydyne Inc 0339									
1750950	7/13/2023	2,970.00 ✓	0.00	07/18/2023				No	0
04-00-6985 Sewer Chemicals					Clarifloc				
	1750950 Total:	2,970.00							
	Polydyne Inc Total:	2,970.00							
USA Blue Book 0449									
INV00022714	7/13/2023	834.31 ✓	0.00	07/18/2023				No	0
02-21-6610 Maint-Site Process Mains					Solenoid Valve 120 VAC 1" NPT				
	INV00022714 Total:	834.31							
INV00022884	7/13/2023	478.89 ✓	0.00	07/18/2023				No	0
02-17-6620 Maint - Water Meters					Meter Coupling w/dual check valve				
	INV00022884 Total:	478.89							
INV00022994	7/13/2023	333.40 ✓	0.00	07/18/2023				No	0
02-21-7030 Water Treatment Chemicals					TNT+ Ammonia Tests, TNT830				
	INV00022994 Total:	333.40							
INV00039388	7/13/2023	31.85 ✓	0.00	07/18/2023				No	0
02-21-7030 Water Treatment Chemicals					Hach Chlorine verf. chemkey				
	INV00039388 Total:	31.85							
	USA Blue Book Total:	1,678.45							

Invoice Number	Account Number	Invoice Date	Amount	Quantity	Payment Date	Task Label	Type	PO #	Close PO	Line #
		Description					Reference			
Whitmore Investments Inc	0472									
June2023s	04-00-6970 Oper Supplies & Tool	7/18/2023	307.47	0.00	07/18/2023				No	0
	June2023s Total:		307.47			June 2023 statement				
June2023se	04-00-6560 Maintenance Sewers Collection	7/18/2023	69.92	0.00	07/18/2023				No	0
	June2023se Total:		69.92			June 2023 statement				
June2023w	02-21-6970 Oper Supplies and Tools	7/18/2023	661.32	0.00	07/18/2023				No	0
	June2023w Total:		661.32			June 2023 statement				
May2023s	04-00-6560 Maintenance Sewers Collection	7/18/2023	53.95	0.00	07/18/2023				No	0
	May2023s Total:		53.95			May 2023 statement				
May2023se	04-00-6970 Oper Supplies & Tool	7/18/2023	325.51	0.00	07/18/2023				No	0
	May2023se Total:		325.51			May 2023 statement				
May2023w	02-21-6970 Oper Supplies and Tools	7/18/2023	385.23	0.00	07/18/2023				No	0
	May2023w Total:		385.23			May 2023 statement				
May2023wa	02-21-6540 Maint-Distribution	7/18/2023	74.54	0.00	07/18/2023				No	0
	May2023wa Total:		74.54			May 2023 statement				
May2023wat	02-21-7010 Uniforms & Accessories	7/18/2023	109.99	0.00	07/18/2023				No	0
	May2023wat Total:		109.99			May 2023 statement				

AP-To Be Paid Proof List (07/18/2023 - 2:18 PM)
 *** means this invoice number is a duplicate.

Invoice Number	Invoice Date	Amount	Quantity	Payment Date	Task Label	Type	PO #	Close PO	Line #
Account Number	Description			Description		Reference			
May2023wate	7/18/2023	16.59 ✓	0.00	07/18/2023				No	0
02-21-6530	Maintenance - Site Grnds/Bldg			May 2023 statement					
	May2023wate Total:	16.59							
	Whitmore Investments Inc	2,004.52							
	Report Total:	46,038.87							

ORDINANCE NO. 23-07-18-02

AN ORDINANCE AMENDING TITLE XI BUSINESS REGULATIONS REGARDING FEES FOR CERTAIN BUSINESS LICENSES, REPEALING CERTAIN ARTICLES AND CHAPTERS, AND RENUMBERING CERTAIN ARTICLES AND CHAPTERS

NOW THEREFORE, BE IT ORDAINED BY THE MAYOR AND CITY COUNCIL OF THE CITY OF WILMINGTON, WILL COUNTY, ILLINOIS, AS FOLLOWS:

SECTION 1: ARTICLES AND CHAPTERS REPEALED

The following Articles and Chapters of Title XI of the City of Wilmington Code of Ordinances are expressly repealed:

Chapter 113, Article 1 – Amusement Licenses
Chapter 113, Article 2 – Billiard Halls and Bowling Alleys
Chapter 113, Article 3 – Circuses
Chapter 113, Article 4 – Motion Pictures and Theatricals
Chapter 113, Article 5 – Public Dances
Chapter 113, Article 6 – Skating Rinks
Chapter 113, Article 7 – Rebound Tumbling Centers
Chapter 113, Article 8 – Musical Entertainment
Chapter 113, Article 9 – Amusement Centers
Chapter 114, Factories – Foreign Insurance Companies
Chapter 115, Article 1 – General Provisions
Chapter 115, Article 2 – Reserved
Chapter 115, Article 3 – Bakeries
Chapter 115, Article 4 – Restaurants
Chapter 116 – Junk Dealers
Chapter 119 – Taxicabs
Chapter 122 – Miscellaneous Licenses

SECTION 2: CHAPTER 111 ARTICLE 1 – OUTDOOR ADVERTISING FEE AMENDED

That **Section 111.04 – Fee** of the City of Wilmington Code of Ordinances is hereby deleted with the following inserted in its place:

Title XI - Business Regulations
Chapter 111 – Advertising
Article 1. – Outdoor Advertising

111.04 - Fee.

The annual fee for advertising licenses shall be \$100.

SECTION 3: CHAPTER 113 ARTICLE 10 - VIDEO GAMING RENUMBERED

That **Chapter 113, Article 10 – Video Gaming** be the same and is hereby renumbered and retitled as follows:

Title XI – Business Regulations
Chapter 113 – Video Gaming
113.000 – Definitions.
113.001 – License Required.
113.002 – License application and fees.
113.003 – Video gaming restrictions.
113.999 – Penalty.

SECTION 4: FOOD TRUCKS RENUMBERED

That **Chapter 115, Article 5 – Food Trucks** be the same and is hereby renumbered as follows:

Title XI – Business Regulations
Chapter 114 – Food Dealers

Article 5 – Food Trucks
114.20 – Definitions.
114.21 – Permit required.
114.22 – Conditions of approval and operation.
114.23 – Permit Fees.
114.24 – Exemptions.
114.25 – Denial of license.
114.26 – Suspension or revocation of license.
114.99 – Penalty.

SECTION 5: FOOD TRUCK PERMIT FEE AMENDED

That **Section 114.23 – Permit Fees** of the City of Wilmington Code of Ordinances is hereby deleted with the following inserted in its place:

Title XI - Business Regulations
Chapter 114 – Food Dealers
Article 2. – Food Trucks
Section 114.23 – Permit Fees.

- (A) Annual license (January 1 through December 31) - \$100.
- (B) All fees required pursuant to this Title shall be paid to the City of Wilmington prior to issuance of the permit.

SECTION 6: TATTOO ESTABLISHMENT FEE AMENDED

That **Section 121.02 – Fees** of the City of Wilmington Code of Ordinances is hereby deleted with the following inserted in its place:

Title XI - Business Regulations
Chapter 121 – Tattoo Establishments
Section 121.02 – Fees.

- (A) Application fee. An application for a license shall be accompanied by a fee in the amount of \$500; provided, however, that no application fee shall be required for renewal of an existing license. Any change of ownership shall require a new application and license, with payment of fees therefor.
- (B) License fee. The annual fee for licenses shall be in an amount as set forth in Section 123.06 of this Code.

SECTION 7: BUSINESS REGISTRATION FEE AMENDED

That **Section 123.06 – Fees** of the City of Wilmington Code of Ordinances is hereby deleted with the following inserted in its place:

Title XI - Business Regulations
Chapter 123 – Business Registration
Section 123.06 – Fees

The fee for a business registration shall as set forth below per year and shall be paid in advance to the city clerk at the time of application, and each year thereafter prior to January 1. The fee for a business registration issued on or after November 1 of any year shall be prorated and will be put into the general finance account. License fees shall be used to fund economic development related expenditures.

- (A) Total square footage (sq. ft.) of less than 5,000 sq. ft.: \$50
- (B) Total square footage of 5,000 sq. ft. and up to 9,999 sq. ft.: \$100
- (C) Total square footage of 10,000 sq. ft. and up to 24,999 sq. ft.: \$250
- (D) Total square footage of 25,000 sq. ft. and up to 49,999 sq. ft.: \$500
- (E) Total square footage of 50,000 sq. ft. and up to 99,999 sq. ft.: \$750
- (F) Total square footage of 100,000 sq. ft. and up to 749,000 sq. ft.: \$1,250
- (G) Total square footage of 750,000 sq. ft. or more: \$1,500

SECTION 8: MOTOR VEHICLE TOWING RENUMBERED

That **Chapter 128 – Motor Vehicle Towing** of Title XI of the City of Wilmington Code of Ordinances be the same and is hereby renumbered as follows:

Title XI – Business Regulations
Chapter 116 – Motor Vehicle Towing

- 116.00 – Solicitation of business at the scene of an accident or emergency.
- 116.01 – Definitions.
- 116.02 – Investigation and approval.
- 116.03 – Insurance.
- 116.04 – Duties and requirements of tow service enter into tow service contract with the city.
- 116.05 – Towing costs paid by city.
- 116.06 – Termination of towing service contract or non-renewal.
- 116.07 – Towing fees.
- 116.08 – Tow operator personnel qualifications.
- 116.09 – Violation and penalty.

**SECTION 9: CANNABIS BUSINESS ESTABLISHMENTS PROHIBITED
RENUMBERED**

That **Chapter 129 – Cannabis Business Establishments Prohibited** of Title XI of the City of Wilmington Code of Ordinances be the same and is hereby renumbered as follows:

- Title XI – Business Regulations
- Chapter 119 – Cannabis Business Establishments Prohibited
- 119.00 – Definitions.
- 119.01 – Cannabis business establishments prohibited.
- 119.02 – Exemptions.
- 119.03 – Public nuisance declared.
- 119.04 – Penalty.

**SECTION 10: ADMISSION TAX ON ATHLETIC CONTESTS AND EXHIBITIONS FOR
GAIN RENUMBERED**

That **Chapter 127– Admission Tax on Athletic Contests and Exhibitions for Gain** of Title XI of the City of Wilmington Code of Ordinances be the same and is hereby renumbered as follows:

- Title XI – Business Regulations
- Chapter 122 – Admission Tax on Athletic Contests and Exhibitions for Gain
- 122.00 – Purpose.
- 122.01 – Definitions.
- 122.02 – Tax.
- 122.03 – Computation of Tax.
- 122.04 – Collection, payment, and accounting.
- 122.05 – Penalties.

SECTION 11: SEVERABILITY

If any section, paragraph, subdivision, clause, sentence or provision of this Ordinance shall be adjudged by any Court of competent jurisdiction to be invalid, such judgment shall not affect, impair, invalidate or nullify the remainder thereof, which remainder shall remain and continue in full force and effect

SECTION 12: REPEALER

All ordinances or parts of ordinances conflicting with any provisions of this ordinance are hereby repealed.

SECTION 13: EFFECTIVE DATE

This Ordinance shall be in full force and effect from and after its passage, approval and publication as provided by law.

PASSED this 18th day of July 2023 with _____ members voting aye, _____ members voting nay, the Mayor voting _____, with _____ members abstaining or passing and said vote being:

Kevin Kirwin _____
Dennis Vice _____
Leslie Allred _____
Todd Holmes _____

Ryan Jeffries _____
Ryan Knight _____
Jonathan Mietzner _____
Thomas Smith _____

Approved this 18th day of July 2023

Ben Dietz, Mayor

Attest:

Joie Ziller, Deputy City Clerk

ORDINANCE NO. 23-07-18-03

AN ORDINANCE OF THE CITY OF WILMINGTON AMENDING ITS LIQUOR LICENSE ORDINANCES TO INCLUDE A CLASS J LIQUOR LICENSE PERMITTING THE SALE OF ALCOHOLIC LIQUOR ON PREMISES FOR LIVE EVENTS AT MOVIE THEATER ESTABLISHMENTS

WHEREAS, the City of Wilmington is authorized under Section 4-1 of the Liquor Control Act (235 ILCS 5/4-1) (hereinafter the “Act”) to determine the number, kind, and classification of licenses, for sale at retail of alcoholic liquor not inconsistent with the Act, the amount of the local licensee fees to be paid for the various kinds of licenses to be issued, and other related regulations; and

WHEREAS, the City of Wilmington finds it in the best interest of the City and its residents to create a liquor license classification to allow for the sale of alcoholic liquor on premises for live events at movie theater establishments and to provide certain regulations for such a liquor license classification as set forth in this Ordinance.

NOW, THEREFORE, BE IT ORDAINED by the City Council of the City of Wilmington, Will County, Illinois, as follows:

SECTION 1: ORDINANCE AMENDED – SECTION 112.06

That the City of Wilmington Code of Ordinances shall be amended to delete and replace Section 112.06 – Classification of Licenses -Fees of Chapter 112 – Alcoholic Liquor Dealers with the following:

Title XI – Business Regulations

Chapter 112 – Alcoholic Liquor Dealers

112.06 – Classification of Licenses - Fees

(A) Licenses are divided into classes as follows:

(1) (a) Class A licenses shall authorize the retail sale on the specified premises of alcoholic liquor only for consumption on the premises. The annual fee for the license shall be \$800 payable in two semiannual installments of \$400 each; the installments shall be due on May 1 and November 1 of each year. No sale of alcoholic liquor shall be permitted in a drive-up or drive-thru or other similar facility. Notwithstanding the foregoing, the Class A license shall allow for the retail sale of alcoholic liquor for off premises use in a dollar amount no greater than 25 percent of the dollar amount of the premises' gross alcoholic beverage sales.

(b) Class A-1 licenses shall authorize the retail sale on the specified premises of craft beers and wines only for consumption on the premises. The annual fee for the license shall be \$800 payable in two semiannual installments of \$400 each; the installments shall be due on May 1 and November 1 of each year. No sale of alcoholic liquor shall be permitted in a drive-up or drive-thru or other similar facility. Notwithstanding the foregoing, the Class A-1 license shall allow for the retail sale of craft beer and wine for off premises use in a dollar amount no greater than 60% of the dollar amount of the premises' gross craft beer and wine sales.

- (2) (a) Class B license shall authorize on the specified premises (i) the retail sale of alcoholic liquor for consumption off the specified premises and (ii) the sale of alcoholic liquor for limited consumption on premises when dispensed in glasses which can hold no more than eight ounces and the premises shall not dispense more than 16 ounces of beer, 12 ounces of wine, or 2 ounces of spirits to any person in a single day. The annual fee for the license shall be \$800 payable in two semiannual installments of \$400 each; the installments shall be due on May 1 and November 1 of each year. No sale of alcoholic liquor shall be permitted in a drive-up or drive-thru or other similar facility.
- (b) Class B-1 licenses shall authorize the wholesale and retail sale on the specified premises of beer and wine but the beer and wine sold shall not be for consumption on the specified premises where sold. The annual fee for the license shall be \$800 payable in two semiannual installments of \$400 each; the installments shall be due on May 1 and November 1 of each year. No sale of alcoholic liquor shall be permitted in a drive-up or drive-thru or other similar facility. If the sale of alcoholic liquor is conducted on premises which are utilized primarily for other retail sales activity, the display of liquor shall be confined to a liquor display area as approved by the liquor commissioner. The liquor display area shall generally be a designated portion of the premises which includes all liquor. In particular, but without limitation, there shall be no aisle displays, or stocking of liquor in any public area of the establishment, except in the approved liquor display area. Any changes to the location or size of the liquor display area shall be approved by the liquor commissioner. The licensee shall cause a sign advising that the area is closed to be conspicuously posted within the liquor display area during those hours that liquor sales are prohibited. In order to qualify for a B-1 license an applicant's alcohol and tobacco sales cannot constitute greater than 50% of the premises' gross sales.
- (c) Class B-2 shall authorize on the specified premises (i) the retail sale of beer and wine for consumption off the specified premises and (ii) the sale of beer and wine for limited consumption on premises when dispensed in glasses which can hold no more than eight ounces and the premises shall not dispense more than 16 ounces of beer or 12 ounces of wine to any person in a single day. The annual fee for the license shall be \$800 payable in two semiannual installments of \$400 each; the installments shall be due on May 1 and November 1 of each year. No sale of alcoholic liquor shall be permitted in a drive-up or drive-thru or other similar facility.
- (3) (a) Class C licenses shall authorize the retail sale of alcoholic liquor upon the specified premises only to members and guests when accompanied by members and shall be issued only to clubs as defined by the Illinois Liquor Control Act, to local lodges of national fraternal organizations, and to other bona fide fraternal pleasure and social associations not organized primarily for the sale or consumption of alcoholic liquor. The annual fee for the license shall be \$400 per year payable in two semiannual installments of \$200 each; the installments shall be due on May 1 and November 1 of each year.
- (b) At the time any application for a Class C license or a renewal thereof is made, the secretary of the organization shall furnish a sworn statement of the number of members as of the date of the application. The affidavit shall be attached to and made a part of the application for license or renewal.
- (c) The aggregate number of Class C licenses to be issued and in effect in the city at any one time shall not exceed two in number.
- (4) (a) Class D licenses shall authorize the retail sale of alcoholic liquor in restaurants only for consumption on the premises in accordance with and only in places where the licensed establishment can keep and maintain at all times during the license term, all of the terms and conditions of a restaurant as defined in Section 112.02 of this chapter.
- (b) The annual fee for a Class D license shall be \$700 per year payable in two equal installments, the first of which shall be deposited with the application for license and thereafter the license fee shall be paid one-half on May 1 and one-half on November 1 of each year.

- (c) Class D-1 licenses shall authorize the retail sale of beer and wine in restaurants, service bar only, only for consumption on the premises in accordance with and only in places where the licensed establishment can keep and maintain at all times during the license term, all of the terms and conditions of a restaurant as defined in Section 112.02 of this chapter.
 - (d) The annual fee for a Class D-1 license shall be \$700 per year payable in two equal installments, the first of which shall be deposited with the application for license and thereafter the license fee shall be paid one-half on May 1 and one-half on November 1 of each year.
- (5) (a) Class E licenses shall authorize the sale of alcoholic liquor by civic, charitable, governmental, or other not-for-pecuniary-profit organizations on specified premises or within an area specifically designated in the license for no longer than a period of 24 hours. Class E licenses shall be available only to such organizations whose offices are located within the city.
- (b) The fee for the issuance of a Class E license for the period allowed shall be \$25 per day.
 - (c) The application for a Class E license shall be made to the liquor commissioner under oath, accompanied by the required fee, and shall contain such information and be in such form as may be required by the liquor commissioner. The liquor commissioner shall determine, in his sole determination, whether it is in the best interests of the city to issue such a license.
 - (d) All of the other terms, conditions and provisions of this chapter shall be applicable to the issuance of a Class E license, except as specifically provided in this subsection (5), and also except that the restrictions under Sections 112.15 and 112.18 may be waived by the local liquor commissioner when the license is issued for the premises owned or occupied by the civic, charitable, governmental, or other not-for-pecuniary-profit organization.
 - (e) Any license issued as a Class E license shall be subject to the following conditions and restrictions:
 - 1. The area operated for sale of alcoholic liquor under a Class E license shall require the same to be adequately fenced with a snow fence of no less than four feet in height or in a defined area or space within a building.
 - 2. The area licensed shall have one or more entrances (not to exceed four in number) of not more than five feet in width each.
 - 3. No person under the age of 21 years shall enter a licensed premises, except in cases where a licensee is selling food; and in that event, a person under the age of 21 years, when accompanied by his parents or legal guardian, may enter the licensed premises with the parent or legal guardian and remain there with the parent or legal guardian until 9:00 p.m. After 9:00 p.m., no person under the age of 21 years shall be allowed in the licensed premises. It shall be the responsibility of the licensee, operator, and employees of the licensee to enforce the time limits set above and to remove persons under the age of 21 years from the licensed premises after 9:00 p.m.
 - 4. No person under the age of 21 years shall be allowed to consume, purchase, or possess any alcoholic liquor in the licensed premises. It shall be the responsibility of the licensee, operator, and employees of the licensee to enforce this age provision by providing a responsible person or persons to check and establish the age of each person consuming alcoholic liquor within the licensed premises.
 - 5. Any violation of this section, state law, or other local ordinance, or any disorder, fighting, or lewd operations shall result in the suspension of the license issued pursuant to this subsection (5), in addition to any other penalty as provided by law.
- (6) (a) Class F licenses shall authorize the retail sale of bottled wine in its original container on specified premises or within an area specifically designated in the license for those businesses where the sale of the bottled wine is an incident to the merchandise generally offered for sale on the premises.

- (b) The wine sold shall not be for consumption on the specified premises where sold. The fee for the issuance of a Class F license shall be \$200.
 - (c) The application for a Class F license shall be made to the liquor commissioner under oath, accompanied by the required fee, and shall contain such information and be in such form as may be required by the liquor commissioner. The liquor commissioner shall determine, in his sole determination, whether it is in the best interests of the city to issue such a license.
 - (d) All of the other terms, conditions and provisions of this chapter shall be applicable to the issuance of a Class F license, except as specifically provided in this subsection (9), and also except that the restrictions under Section 112.18 may be waived by the local liquor commissioner.
 - (e) Any license issued as a Class F license shall be subject to the following conditions and restrictions:
 - 1. The display of liquor shall be confined to a liquor display area as approved by the liquor commissioner. The liquor display area shall generally be a designated portion of the premises which includes all liquor. In particular, but without limitation, there shall be no aisle displays, or stocking of liquor in any public area of the establishment, except in the approved liquor display area. Any changes to the location or size of the liquor display area shall be approved by the liquor commissioner. The licensee shall cause a sign advising that the area is closed to be conspicuously posted within the liquor display area during those hours that liquor sales are prohibited. In order to qualify for a F license an applicant's alcohol and tobacco sales cannot constitute greater than 25% of the premises' gross sales.
 - 2. The total number of wines available shall not exceed 12.
 - 3. The area licensed shall have one or more entrances (not to exceed four in number) of not more than five feet in width each.
 - 4. No person under the age of 21 years shall be allowed to consume, purchase, or possess any alcoholic liquor in the licensed premises. It shall be the responsibility of the licensee, operator, and employees of the licensee to enforce this age provision by providing a responsible person or persons to check and establish the age of each person consuming alcoholic liquor within the licensed premises.
 - 5. Any violation of this section, state law, or other local ordinance, or any disorder, fighting, or lewd operations shall result in the suspension of the license issued pursuant to this subsection (6), in addition to any other penalty as provided by law.
- (7) (a) Class G licenses shall authorize the retail sale and dispensing of alcoholic liquor for consumption at an outdoor sporting/entertainment facility of the licensed premises, and within the building of the licensed premises at or over a bar or bars, service bar or bars and at tables for businesses operating as a banquet facility for private parties scheduled in advance including, but not limited to, wedding receptions, political and charitable fund-raisers, club gatherings, sports banquets, anniversary parties, reunions, holiday parties, appreciation gatherings, company parties and similar events.
- (b) The aggregate number of Class G licenses to be issued and in effect in the city at any one time shall not exceed one in number.
 - (c) The annual fee for a Class G license shall be \$1,900 payable in two semiannual installments of \$950 each. One-half of the first installment shall be deposited with the application for license, the balance of the annual fee is to be due and payable on November 1 following and thereafter the license fee shall be paid one-half on May 1 and one-half on November 1 of each year.
- (8) Class H licenses shall authorize the licensee to sell alcoholic liquor to its patrons and guests by the drink, for consumption in the clubhouse and on the golf course, and not for resale in any form. The license shall only be available for premises defined as "golf course/clubhouse" herein which has a minimum of 100 total acres for an 18-hole or greater course or a minimum of 50 total acres for a nine-hole course. "Golf course/clubhouse" means a public or private golf course with a clubhouse having a facility used, kept

and maintained as a place where food is served, such space being provided with adequate and sanitary kitchen and dining room equipment and capacity and having employed therein of sufficient number and kind, employees to prepare, cook and serve suitable food for its guests. The annual fee for a Class H license shall be \$800 payable on May 1 of each year.

- (9) Class I. During authorized hours of business, Class I-1 or I-2 licensee may offer for onsite consumption samples of beer and/or cider brewed or manufactured on the licensed premises by the licensee and permitted to be sold pursuant to this classification. Licensees shall not provide more than three (3) free samples; no single serving of beer or cider shall exceed two (2) ounces. Said tasting shall be for the purpose of disseminating product information and education with consumption of beer being an incidental part of the presentation. Sampling shall be under the supervision of the license holder or duly authorized agent and be conducted in a manner which will confine the consumption on the licensed premises solely for the purpose of providing samples in connection with anticipated sales.
- (a) Class I-1 (Brew Pub) license shall authorize the manufacturing or brewing and storage of beer and/or cider on the licensed premises for sale to importing distributors, distributors, and to non-licensees for use and consumption only, the retail sale of alcoholic liquor for consumption on the premises and in the original package for consumption off the premises, the retail sale of beer and/or cider brewed or manufactured on the licensed premises for consumption on the premises and in its original package for consumption off the premises, and shall include a full kitchen and such facility shall be properly licensed as a food service establishment. This class shall permit entertainment on the licensed premises and the licensee shall maintain in good standing a State of Illinois brew pub license as required and authorized under the Illinois Liquor Control Act (235 ILCS 5/1 et seq.), as amended. The annual fee for a Class I-1 license shall be \$800, payable in two installments of \$400 each, the first installment of which shall be deposited with the application for a license and the second installment to be due and payable on May 1 or November 1, whichever occurs first.
- (b) Class I-2 (Craft Brewery) license shall authorize the manufacturing or brewing and storage of beer and/or cider for the retail sale for consumption on the premises and also authorize the retail sale of beer and/or cider in its original package for consumption off the premises, and may include a full kitchen provided such facility is properly licensed as a food service establishment. The licensee shall maintain in good standing a State of Illinois Class 1 Brewer or Class 2 Brewer license authorized under the Illinois Liquor Control Act (235 ILCS 5/1 et seq.), as amended. The annual fee for a Class I-2 license shall be \$450, payable in two installments of \$225 each, the first installment of which shall be deposited with the application for a license and the second installment to be due and payable on May 1 or November 1, whichever occurs first.
- (10) Class J License (Movie Theater Live Events) shall authorize the sale of alcoholic liquor only for consumption indoors on the premises for live events only at movie theater establishments only. The service and sale of alcoholic liquor shall only be permitted at a bar in a designated area where entry is prohibited by persons under the age of 21. It shall be the responsibility of the licensee, operator, and employees of the licensee to enforce the age restriction by providing a responsible BASSET trained person or persons to check and establish the age of each person entering into the designated area. Class J licenses shall be limited to alcoholic liquor service for no more than twelve live events per year and no more than 60 minutes before the event and in no event longer than five hours of alcoholic liquor service per live event. The fee for the issuance of a Class J license shall be \$500 per year.
- (11) Class W licenses (Wine tasting events) shall be defined as: an event encompassing no more than eight consecutive hours at which wine is dispensed in glasses which can hold no more than two oz. of wine; the total two oz. servings per person shall not exceed six for the event.
- (a) Class W licenses shall entitle the holder thereof to hold a wine tasting event.
- (b) Class W licenses shall only be available to the holders of a Class A; Class A1; Class B; Class E; or Class F license.

- (c) The application for a Class W license shall be made to the liquor commissioner under oath, accompanied by the required fee, and shall contain such information and be in such form as may be required by the liquor commissioner. The liquor commissioner shall determine, in his sole determination, whether it is in the best interests of the city to issue such a license.
- (d) All of the other terms, conditions and provisions of this chapter shall be applicable to the issuance of a Class W license, except as specifically provided in this subsection (9), and also except that the restrictions under Section 112.18 may be waived by the local liquor commissioner.
- (e) Any license issued as a Class W license shall be subject to the following conditions and restrictions:
 - 1. A Class W license shall only be valid for one day as specified in the license.
 - 2. A holder of a Class A, Class B, Class E, or Class F license shall be allowed no more than four Class W licenses per calendar year.
 - 3. The license holder shall not charge for admittance to the event nor receive compensation of any kind from the event goers nor from any other party.
- (B) Any person, firm, or corporation having a retail liquor license in full force and effect on November 1, 1959, shall, if otherwise eligible under the terms of this chapter, be permitted to secure a renewal of the license from year to year so long as the license shall not at any time be revoked or permitted to lapse. The renewals shall be continuous, however, for the purpose of determining the continuity of license renewals, as above set forth, the widow of any deceased licensee (who held a license on November 1, 1959, which has never been permitted to lapse) or such adult child of the deceased licensee as the widow may designate shall, if otherwise qualified, be deemed one and the same as the deceased licensee. Or if there shall be no widow, then the eldest resident adult child of the deceased licensee may make the designation. If there is no widow or adult child of the deceased licensee, then the license shall not be renewable.

('68 Code, § 112.025; Am. Ord. 689, passed 5-4-76; Am. Ord. 737, passed 10-17-78; Am. Ord. 774, passed 12-18-79; Am. Ord. 785, passed 4-15-80; Am. Ord. 837, passed 11-17-81; Am. Ord. 923, passed 10-2-84; Am. Ord. 926, passed 12-4-84; Am. Ord. 996, passed 2-17-87; Am. Ord. 1005, passed 5-5-87; Ord. 1516, passed 3-18-03; Am. Ord. 10-07-06-03, § 1, passed 7-6-10; Am. Ord. 11-10-18-01, § I, passed 10-18-11; Am. Ord. 14-11-18-02, § 1, passed 11-18-14; Am. Ord. 16-10-18-02, § 1, passed 10-18-16; Am. Ord. 18-04-17-01, passed 4-17-18; Ord. No. 19-01-15-01, § 2, 1-15-19; Am. Ord. 20-04-21-03, §§ 1A, 1B, passed 4-21-20) Penalty, see Section 112.99

SECTION 2: ORDINANCE AMENDED – SECTION 112.23

That the City of Wilmington Code of Ordinances shall be amended to delete and replace Section 112.23 – Hours during which sale are permitted of Chapter 112 – Alcoholic Liquor Dealers with the following:

Title XI – Business Regulations

Chapter 112 – Alcoholic Liquor Dealers

112.23 Hours during which sales are prohibited.

- (A) No licensee shall keep open or allow his place of business to remain open or sell or offer for sale at retail, or offer to give away on any licensed premises, any alcoholic liquor in the city during the following hours:
 - (1) Class A and C license.
 - (a) Tuesday through Friday inclusive: Between the hours of 1:00 a.m. and 6:00 a.m.;
 - (b) Saturday: Between the hours of 2:00 a.m. and 6:00 a.m.;
 - (c) Sunday: Between the hours of 2:00 a.m. and 8:00 a.m.;

- (d) Monday: Between the hours of 1:00 a.m. and 6:00 a.m.
- (2) Class B, B-1, and B-2 license.
 - (a) Monday: between the hours of midnight and 6:00 a.m. and Monday through Thursday between the hours of 11:00 p.m. and 6:00 a.m. the following day;
 - (b) Saturday: Between the hours of midnight and 6:00 a.m.;
 - (c) Sunday: Between the hours of midnight and 6:00 a.m.
- (3) Class D and D-1 license.
 - (a) Tuesday through Friday inclusive: No service from 1:00 a.m. to 6:00 a.m.;
 - (b) Saturday: No service from 1:00 a.m. to 6:00 a.m.;
 - (c) Sunday: No service from 1:00 a.m. to 8:00 a.m.;
 - (d) Monday: No service from midnight to 6:00 a.m.
- (4) Class G, H, and J license.
 - (a) Monday through Friday inclusive: No service from 1:00 a.m. to 7:00 a.m.;
 - (b) Saturday: No service from 2:00 a.m. to 7:00 a.m.;
 - (c) Sunday: No service from 2:00 a.m. to 7:00 a.m.
- (B) Sale of alcoholic liquors shall cease immediately at the aforesaid first hour noted above. Members of the general public must leave the licensed premises before the closing hours herein established. Any license so further restricted as to time shall, when issued, indicate on the face thereof the hours during which the licensee thereunder may keep open or allow his place of business to remain open as aforesaid. The local liquor control commissioner may, at his discretion, further reasonably restrict the above general hours during which any licensee may keep open or allow his place of business to remain open, or sell or offer for sale or offer to give away any alcoholic liquor at any licensed premises when in the local liquor control commissioner's judgment, a further restriction would be in the best interest of the public and the city and in furtherance of the general welfare and safety thereof. Should any person other than the licensee, members of his family, or his employees, agents, or servants be found upon or leaving the licensed premises after the closing hour, the city shall have the right to presume that the person was served alcoholic liquor after the closing hour and the presumption may be raised in any court or other legal proceeding for the violation of the terms of this section or any hearing concerning the suspension or revocation of the license issued to the licensee of the premises in question.

('68 Code, § 112.110; Am. Ord. 685, passed 1-6-76; Am. Ord. 1179, passed 12-29-93; Am. Ord. 11-10-18-01, § II, passed 10-18-11; Am. Ord. 12-05-22-01, § 1, passed 5-22-12; Am. Ord. 15-12-15-01, § 1, passed 12-15-15; Am. Ord. 20-04-21-03, § 2, 4-21-20) Penalty, see Section 112.99

SECTION 3: ORDINANCE AMENDED – SECTION 112.25

That the City of Wilmington Code of Ordinances shall be amended to delete and replace Section 112.25 – Number of liquor license authorized of Chapter 112 – Alcoholic Liquor Dealers with the following:

Title XI – Business Regulations

Chapter 112 – Alcoholic Liquor Dealers

112.25 Number of liquor licenses authorized.

- (A) There shall be available, for issuance by the local liquor control commissioner, the following number of licenses for each of the following classifications of liquor licenses:

Classification	Maximum Number Authorized
Class A liquor license (Retail sale-bar)	9
Class A-1 license	1
Class B liquor license (Wholesale-retail/carryout)	4
Class B-1 liquor license (Wholesale-retail/carryout, beer and wine only)	4
Class B-2 liquor license (Retail/carryout, beer and wine only with limited on-premises consumption)	1
Class C liquor license (Fraternal organizations)	2
Class D liquor license (Restaurants)	5
Class D-1 liquor license (Restaurants-beer, wine only)	3
Class E liquor license (Not-for-profit organizations/24-hour maximum)	There is no limitation upon the number of Class E liquor licenses, but the issuance of this Class "E" license is entirely within the discretion of the local liquor control commissioner.
Class F liquor license (Limited retail sales-wine only)	2
Class G liquor license (Outdoor sporting event/entertainment)	1
Class H liquor license (Golf course/clubhouse)	1
Class I-2 licenses	1
Class J licenses (Movie Theater Live Events)	1
Class W liquor license (Wine tasting event)	No more than 2 at any one time

- (B) Liquor licenses shall be issued for a fiscal year beginning May 1 of each year. If a license is issued during the first six months of the fiscal year, the applicant shall pay a full year license fee, as provided by city ordinance. If a license is issued during the last six months of the fiscal year, the applicant shall pay a one-half year license fee.

(Ord. 774, passed 12-18-79; Am. Ord. 785, passed 4-15-80; Am. Ord. 802, passed 2-3-81; Am. Ord. 823, passed 7-7-81; Am. Ord. 1090, passed 3-28-90; Am. Ord. 1151, passed 7-21-92; Am. Ord. 1171, passed 6-1-93; Am. Ord. 1249, passed 2-4-97; Am. Ord. 1271, passed 2-3-98; Am. Ord. 1298, passed 11-3-98; Am. Ord. 10-07-06-03, § 1, passed 7-6-10; Am. Ord. No. 10-07-20-03, § 1, passed 7-20-10; Am. Ord. No. 11-02-15-02, § 1, passed 2-15-11; Am. Ord. 11-10-18-01, § III, passed 10-18-11; Am. Ord. 14-11-18-02, § 1, passed 11-18-14; Am. Ord. 15-07-07-01, § 1, passed 7-7-15; Am. Ord. 17-11-21-03, § 1, 11-21-17; Ord. No. 19-01-15-01, § 3, 1-15-19; Am. Ord. 20-04-21-03, § 3, 4-21-20; Am. Ord. 21-06-15-02, passed 6-15-21; Am. Ord. 21-09-21-01, § 1, passed 9-21-21; Ord. 22-10-04-01, passed 10-4-22) Penalty, see Section 112.99

SECTION 4: SEVERABILITY

If any section, paragraph, subdivision, clause, sentence or provision of this Ordinance shall be adjudged by any Court of competent jurisdiction to be invalid, such judgment shall not affect, impair, invalidate or nullify the remainder thereof, which remainder shall remain and continue in full force and effect

SECTION 5: REPEALER

All ordinances or parts of ordinances conflicting with any provisions of this ordinance are hereby repealed.

SECTION 6: EFFECTIVE DATE

That this Ordinance shall be in full force and effect after its adoption and approval, as provided by law.

PASSED this ____ day of _____, 2023 with ____ members voting aye, ____ members voting nay, the Mayor voting _____, with ____ members abstaining or passing and said vote being:

Kevin Kirwin	_____	Ryan Jeffries	_____
Dennis Vice	_____	Ryan Knight	_____
Leslie Allred	_____	Jonathan Mietzner	_____
Todd Holmes	_____	Thomas Smith	_____

Approved this ____ day of _____, 2023

Ben Dietz, Mayor

Attest:

Deputy City Clerk

GASKILL & WALTON CONSTRUCTION COMPANY

TELEPHONE: 708-758-1050
FAX: 708-758-1060
EMAIL jbowmangandw@gmail.com

MAILING ADDRESS:
P.O. BOX 367
CHICAGO HEIGHTS,
ILLINOIS 60411-0367

SHIPPING ADDRESS:
22480 MILLER ROAD
STEGER, ILLINOIS 60475

June 20, 2023,

RE: City of Wilmington
North Island L.S.

James and Patrick,

This letter is our proposal to upgrade the Lift Station. We will do all necessary Demo to complete our work. This price includes furnishing and installing a new 120-240 volt 3 phase four wire service, which we will coordinate with Commed, 100A Meter, 100A NEMA 3R service rated fused disconnect switch, 100A manual transfer switch, lighting panel, control panel, all feeders to the Commed pole, junction box, floats, transducer, 2 new pumps, 2 new MTM base 90's, new MTM sealing flanges, We will modify bottom of riser pipes as needed to make new bases work, new S.S. rails, top rail supports, Anchor, stainless steel chain for pumps and anchor, stainless steel shackles, stainless steel float bracket with hooks for weighted floats, new vent pipe for wet well, 2 - 4" 2-way worm driven plug valves, 2 - 4" 90's, 1 - 4" Tee, new hatches poured in new concrete lids. A new 1" conduit approx. 31' south of station.

Regarding the platform. This would be 5'-0" wide x 11'-0" long. We would use galvanized grating, galvanized stair treads, galvanized pipe with galvanized mechanical fittings. We would make the stringers out of carbon steel c channel & the main structure would be 4"x4"x1/4" square tubing which we would galvanize after fabrication. We would build this on a 1'-0" concrete pad for the legs to be anchored to.

The city will install a bypass valve and riser set up on the south side of valve vault before job starts. The city will plug and bypass pump when the time comes. Once they do this, they will jet station and Vac Truck it out. We will keep temporary pumping down to 1 or 2 weeks at the most. We will do as much work as we can before by-pass pumping starts. We have included a day for start-up and training. Our price to do this work is \$289,000.00. Commed is approx. 16 weeks out if we ordered today.

We do not include permits, painting, Bonds, or anything not listed. We appreciate the opportunity and hope our price is favorable. Please call if you have any questions.

YOURS VERY TRULY,
GASKILL & WALTON CONSTRUCTION CO.
JEFFREY R BOWMAN
JEFFREY R BOWMAN, PRESIDENT

ITEM NO.	PART NUMBER	DESCRIPTION	QTY.
1	CONCRETE WET WELL	5'-0" DIA. EXISTING	1
2	CONCRETE FLEET	BY OTHERS	1
3	APD300-30x44	DUPEX ALUMINUM ACCESS HATCH	1
4	APD300-30x44	DUPEX SAFETY GRATE	1
5	UPPER GUIDE RAIL SUPPORTS	FOR 2" RAIL SYSTEM	2
6	4" MIN. ELBOW		2
7	4" MIN. ELBOW		2
8	4" MIN. ELBOW		2
9	4" MIN. ELBOW		2
10	4" MIN. ELBOW		2
11	4" VERT. SPRING		1
12	4" VERT. SPRING		1
13	4" VERT. SPRING		1
14	4" VERT. SPRING		1
15	4" VERT. SPRING		1
16	4" VERT. SPRING		1
17	VEGAPULS C21	RADAR LEVEL TRANSDUCER	1
18	VALVE VAULT	5'-0" DIA. EXISTING	1
19	AP5300-42x34	42"x58" OPENING	1
20	AP5300-42x34	SIMPLEX SAFETY GRATE	1
21	ALUMINUM LADDER	W/ SAFETY POST	1
22	INFLIGHT PIPE	BY CONTRACTOR	1
23	4" S.R. ELBOW	D.I. FITTING	4
24	4" PLUG VALVE		3
25	1" CONDUIT	BY OTHERS	2
26	2 CONDUIT	BY OTHERS	3
27	6"x4" CROSS	D.I. FITTING	2
28	4" 90° SWING CHECK VALVE		1
29	4" GULCH CONNECT COUPLING FLANGED	MALE END	1
30	6"x4" SR	REDUCING ELBOW	1
31	FILLER FLANGE	BY OTHERS	1

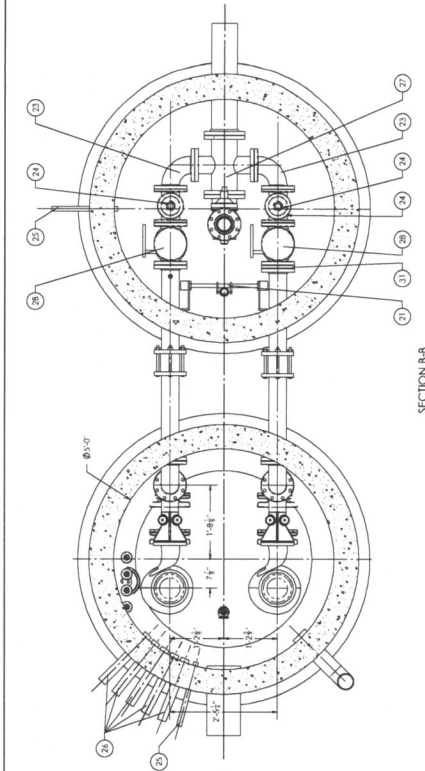

- NOTES:**
- THIS DRAWING IS A PRELIMINARY LAYOUT ONLY. NOT FOR CONSTRUCTION. CONSTRUCTION DRAWINGS WILL BE FORWARDED UPON RECEIPT OF APPROVED SUBMITTALS.
 - SOME ITEM VALUES ARE TO BE PROVIDED BY CONTRACTOR, UNLESS NOTED OTHERWISE.
 - METROPOLITAN PUMP TO PROVIDE ONLY THE ITEMS SHOWN IN BOLD. CONTRACTOR TO PROVIDE ALL OTHER ITEMS.
 - CONTRACTOR TO ORDER CONTROL & POWER CORDS OF SUFFICIENT LENGTH TO REACH CONTROL PANEL FROM POINT OF ORIGIN ON PUMPS WITHOUT SPlicing.
 - ALL CONCRETE WORK AND CONDUIT WORK ARE THE RESPONSIBILITY OF THE CONTRACTOR TO VERIFY ALL DIMENSIONS, ELEVATIONS, PIPING LAYOUTS, AND ORIENTATION OF INLETS, DISCHARGE, AND CONDUITS.
 - ELECTRICAL COMPONENTS IN THE WET WELL SHALL BE RATED FOR CLASS I, DIV. 1, GROUP C & D LOCATIONS.
 - CONDUITS ARE AS FOLLOWS: (1) 2" FOR EACH PUMP POWER CORD, (1) 2" FOR EACH CONTROL CORD, (1) 2" FOR LEVEL CONTROL AND (1) 1" FOR RADAR LEVEL TRANSDUCER.

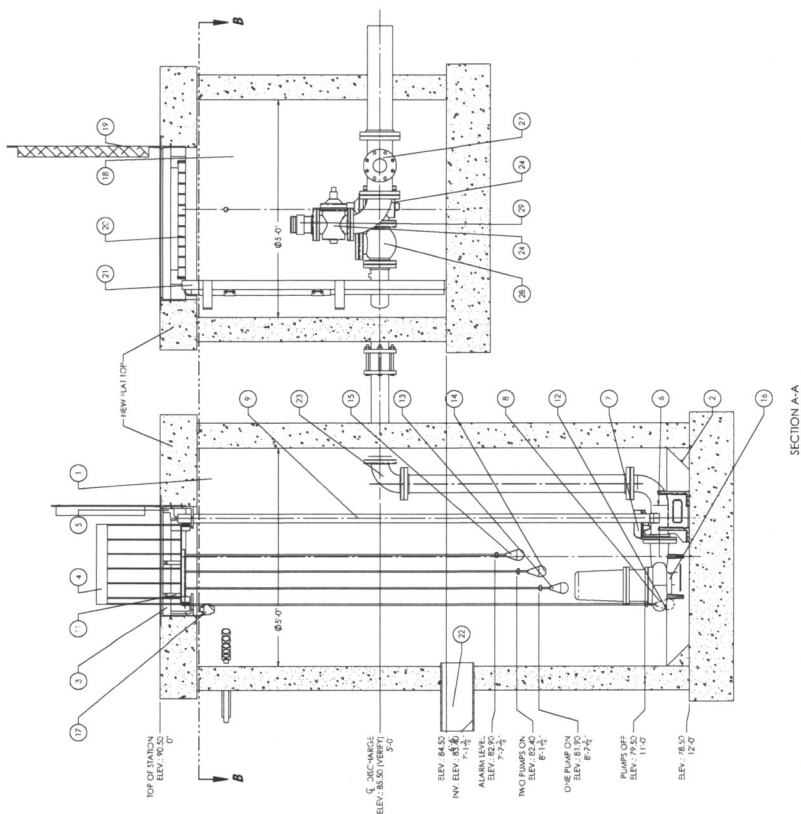
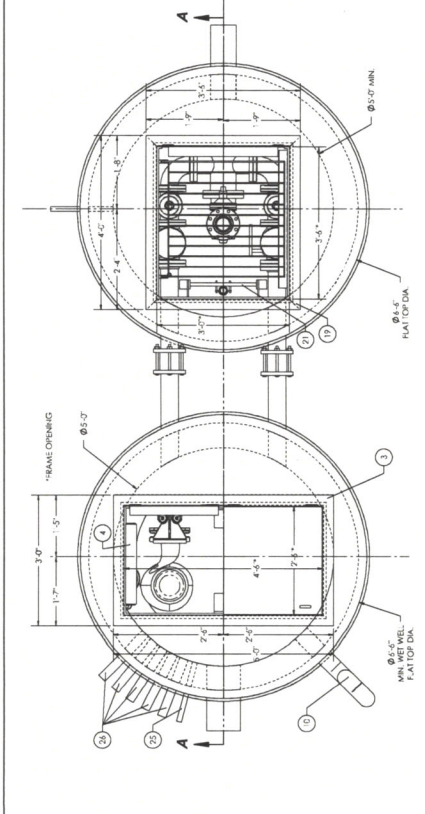

DATE: 5/19/2023
 BY: VALUE VAULT F.T. HATCH LOCATION PER SITE VISIT
 REVISION: 1
 DATE: 5/17/2023
 APP. BY:

SCALE: 1:16
 DATE: 5/17/2023
 APP. BY:

NOT FOR BIDDING PURPOSES

METROPOLITAN INDUSTRIES, INC.
 37 FORESTWOOD DR. ROMEOVILLE, ILLINOIS 60448
 (618)888-8800 FAX (618)888-8803
 PUMPS - CONTROLS - SYSTEMS

PROJECT: DUPEX SANITARY LIFT STATION NORTH ISLAND LIFT STATION REHAB WILMINGTON, ILLINOIS

TITLE: DUPEX METRO-RAIL COMPONENT LIFT STATION

CHAIN AND ANCHOR LEVEL CONTROL INCLUDING BEAR (N/S)

SHEET 1 OF 1
 DATE: 5/17/2023
 DRAWN BY: JLM
 CHECKED BY: JLM

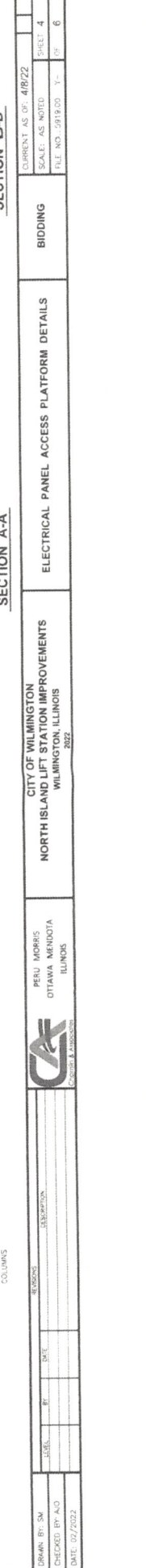
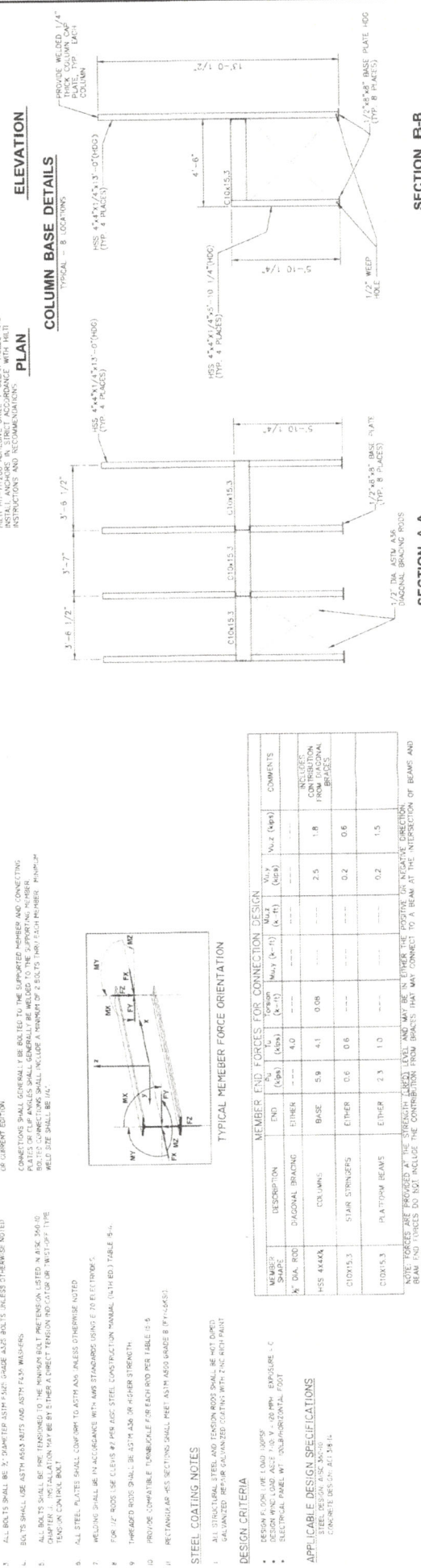
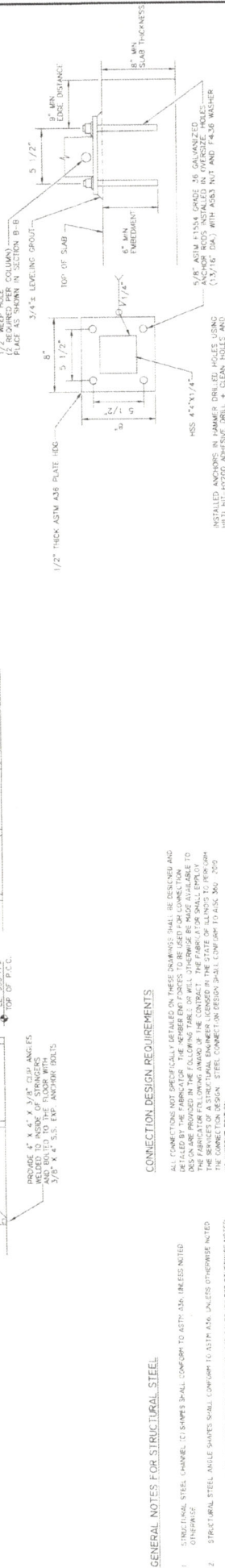
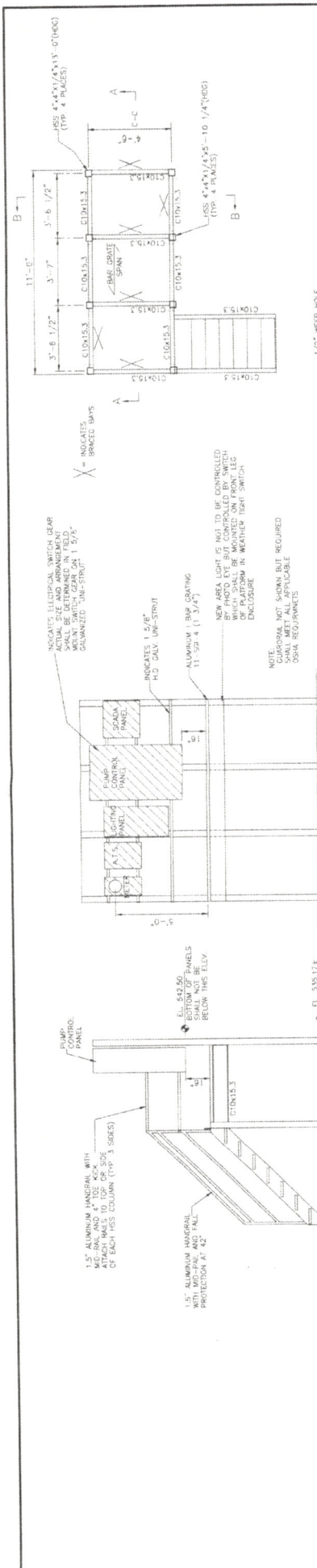

GENERAL NOTES FOR STRUCTURAL STEEL

- STRUCTURAL STEEL CHANNEL TO SHAPES SHALL CONFORM TO ASTM A36, UNLESS NOTED OTHERWISE.
- STRUCTURAL STEEL ANGLE SHAPES SHALL CONFORM TO ASTM A36, UNLESS OTHERWISE NOTED.
- ALL BOLTS SHALL BE 3/4" DIAMETER ASTM F4170 GRADE 5 BOLTS UNLESS OTHERWISE NOTED.
- BOLTS SHALL USE ASTM A503 NUTS AND ASTM F4170 WASHERS.
- ALL BOLTS SHALL BE PRE TENSIONED TO THE MANUFACTURER'S TENSIONING METHOD. TENSIONING SHALL BE BY EITHER A DIRECT TENSION INDICATOR OR WEST-OF-TYPE TENSION CONTROL BOLT.
- ALL STEEL PLATES SHALL CONFORM TO ASTM A588 UNLESS OTHERWISE NOTED.
- WELDING SHALL BE IN ACCORDANCE WITH AWS STANDARD SPECIFICATIONS FOR ELECTRODES.
- FOR 1/2" RODS USE CLASS #2 PER AISC STEEL CONSTRUCTION MANUAL (LH 10.1) TABLE 9.4.
- THREADED RODS SHALL BE ASTM A306 OR HIGHER STRENGTH.
- PROVIDE COMPATIBLE FINISHES FOR EACH ROD PER TABLE 9.4.
- RECTANGULAR HSS SECTIONS SHALL MEET ASTM A500 GRADE B (F44-24.5).

STEEL COATING NOTES

- ALL STRUCTURAL STEEL AND TENSION RODS SHALL BE HOT DIPPED GALVANIZED REPAIR GALVANIZED COATING WITH 2.0 INCH PAINT.

DESIGN CRITERIA

- DESIGN FLOOR LIVE LOAD 200 PSF
- DESIGN WIND SPEED 105 MPH
- ELECTRICAL PANEL WITH VOLTAGE HORIZONTAL FOOT

APPLICABLE DESIGN SPECIFICATIONS

STEEL DESIGN: AISC 360-16
 CONCRETE DESIGN: ACI 318-14

CONNECTION DESIGN REQUIREMENTS

ALL CONNECTIONS NOT SPECIFICALLY DETAILED ON THESE DRAWINGS SHALL BE DESIGNED AND DETAILED BY THE FABRICATOR. THE MEMBER END FORCES TO BE USED FOR CONNECTION DESIGN ARE PROVIDED IN THE FOLLOWING TABLE OR WILL OTHERWISE BE MADE SUBJECT TO THE SERVICES OF A STRUCTURAL ENGINEER LICENSED IN THE STATE OF ILLINOIS TO PERFORM THE CONNECTION DESIGN. STEEL CONNECTION DESIGN SHALL CONFORM TO AISC 360, 709 OF CURRENT EDITION.

CONNECTIONS SHALL GENERALLY BE BOLTED TO THE SUPPORTED MEMBER AND CONNECTING PLATES OR CLIP ANGLES SHALL GENERALLY BE WELDED TO THE SUPPORTED MEMBER. ANCHORAGE SHALL INCLUDE AN ANCHOR PLATE OR ANCHOR BOLTS TO THE SUPPORTED MEMBER. ANCHOR WELD SIZE SHALL BE 1/4".

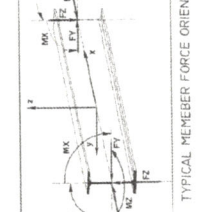

TYPICAL MEMBER FORCE ORIENTATION

MEMBER END	DESCRIPTION	END X (ft)	END Y (ft)	END Z (ft)	TO CONNECTION			COMMENTS
					Mx (k-ft)	My (k-ft)	Mz (k-ft)	
N DIA ROD	DIAGONAL BRACING	---	---	---	4.0	---	---	---
HSS 6X4X4	COLUMNS	5.9	4.1	0.06	---	---	---	INCLUDE CONNECTION FROM DIAGONAL BRACING
C10X15.3	STAR STRUNGERS	0.6	0.6	---	---	---	---	0.2
C10X15.3	PLATFORM BEAMS	2.3	1.0	---	---	---	---	0.2

NOTE: FORCES ARE PROVIDED AT THE STRENGTH LEVEL AND MAY BE EITHER THE POSITIVE OR NEGATIVE MEMBER END FORCES. BEAM END FORCES DO NOT INCLUDE THE CONTRIBUTION FROM BRACES THAT MAY CONNECT TO A BEAM AT THE INTERSECTION OF BEAMS AND COLUMNS.

DRAWN BY: SM
 CHECKED BY: AJO
 DATE: 02/2022

PERU MORRIS
 OTTAWA MENONDA
 ILLINOIS

CITY OF WILMINGTON
 NORTH ISLAND LIFT STATION IMPROVEMENTS
 WILMINGTON, ILLINOIS
 2022

REVISIONS

NO.	DATE	DESCRIPTION

SECTION A-A

SECTION B-B

CURRENT AS OF: 4/19/22

SCALE: AS NOTED

SHEET: 4

FILE NO.: 2019103

Y: 05

6

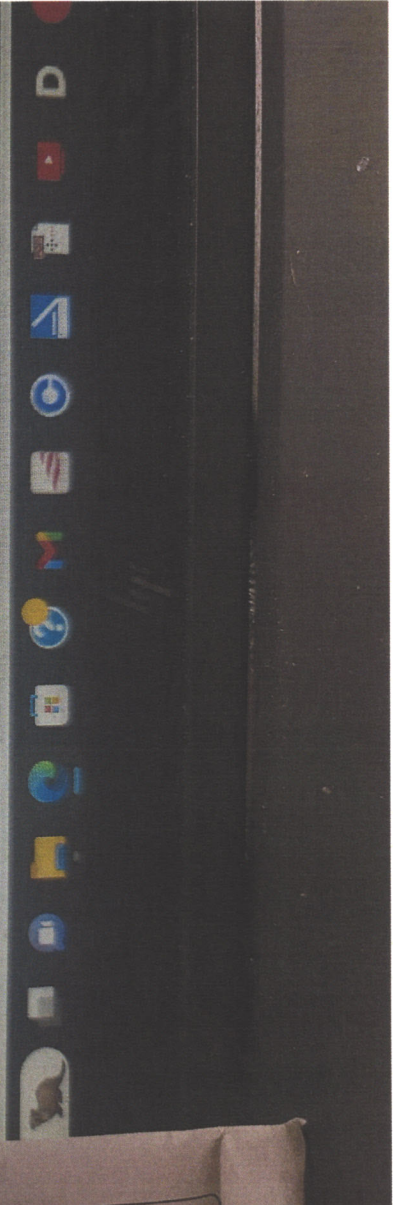
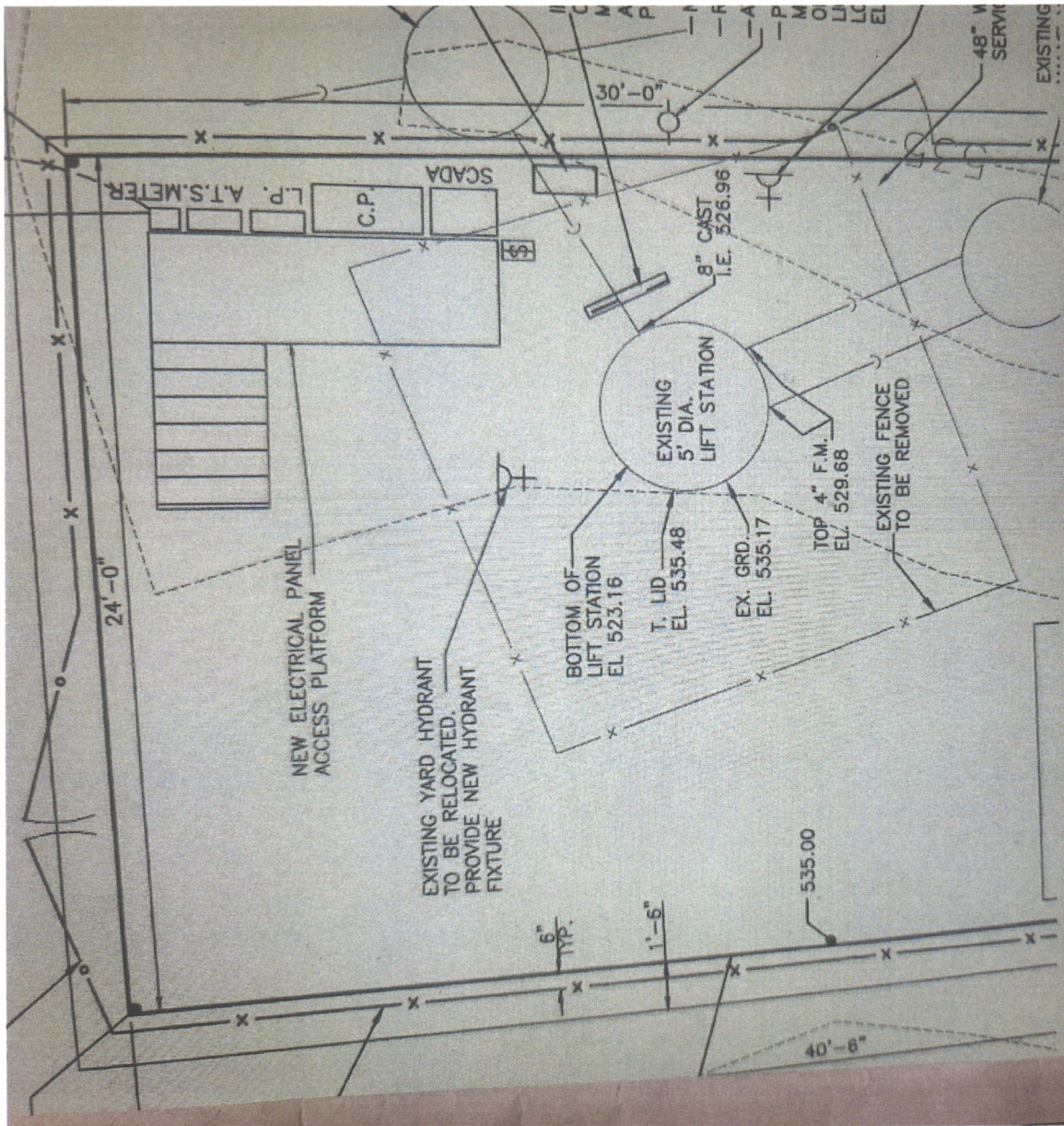

Order Acknowledgement



DATE

6/12/2023

ORDER NO.

35462

B Wilmington, City Of
I 1165 S Water St
L Waste Water Treatment Plant
L Wilmington , IL 60481-8864
USA
T
O

S Wilmington, City Of
H 601 E Kankakee River Dr
I Waste Water Treatment Plant
P Wilmington , IL 60481-8864
USA
T
O

CUST NO.	SALES AGENT	CUSTOMER SERVICE REP	SHIP TO ID	PO NUMBER	ORDER TYPE	
100734	John Dunlap	Summer Nehl	10	PWN61223	Direct	
SHIP DATE	ALT SHIP DATE	DEL TYPE	SHIP VIA	FREIGHT TERMS	F.O.B. REMARK	
6/19/2023	6/19/2023	Regular	Vendor Truck	Direct Delivered	Destination	
QUANTITY ORDERED	PACKAGING	DESCRIPTION	NET WT	GROSS WT	PRICE/UNIT	EXTENDED PRICE

27,750	1.00 lb Bulk	Aluminum Sulfate Liq Aluminum Sulfate Alum Sulfate 1 Lb Bulk DS 60300-89201000 Whs: DIR Lot: N/A	27,750	27,750	0.1975/lb	5,480.63
--------	-----------------	--	--------	--------	-----------	----------

TOTAL: 5,480.63
Actual Invoice Total is \$5,522.10

General Remarks: ***3000 GALLONS MAX ALUM SULF***
 CONTACT: PATRICK #815-476-5663 / 815-693-0327 CALL ABOUT 1/2 HR BEFORE DELIVERY
 RCVING HRS: 7 AM - 3 PM
 100FT HOSE / 2"
 ALT CONTACT: DARREN
 Phone: 815-922-5867
 Alt phone Patrick @ 815-693-0327

KDI – KUBINSKI DIVING INDUSTRIES, LLC
3105 E 1951st Rd
(815)993-0584
Ottawa, IL 61350-9768
kzkubinski@kdidiving.com
tadkubinski@kdidiving.com

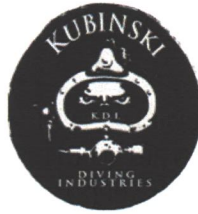

EXECUTIVE SUMMARY
CITY OF WILMINGTON WATER INTAKE SYSTEM MAINTENANCE

Date: 06-05-2023---- 06-06-2023	Diver: Tony Laskanich
Time: 0700	Dive Supervisor: Kaz Kubinski
Location: Wilmington, IL	City Water Intake System

Job Summary:

KDI employees inspected and pumped sediment on both water intake screens. KDI divers began diver dredging operations on June 5th and finished on June 6th. The sediment level on both screens was approximately 80% over the barrel screen before the dredging began. After the dredging, both screens are 100% clear of sediment build up.

Upstream Intake:

The upstream intake had sediment 80% over the barrel screen restricting water flow. KDI divers began dredging the upstream intake on and finished the same day. All sediments were removed from around the upstream barrel screen. The barrel screen is in good condition.

Downstream Intake:

The downstream intake had sediment 85% over the barrel screen restricting a significant amount of water flow. KDI began dredging the downstream barrel screen on June 6th and finished the same day. All sediments were removed from around the downstream barrel screen. The barrel screen is in good condition.

****See attached CAD Drawing and video inspection attached in email****

Submitted By: Kaz Kubinski

Disclaimer: The information provided is for the limited administrative and operational use of City of Wilmington and their contractors. Other requests for this document shall be referred to KDI DIVING, LLC. The accuracy of the information provided is limited to the conditions of the site and to the day of inspection.

KDI DIVING
 3105 E 1951 Rd. Ottawa, IL 61350
 815.993.0584
 kazkubinski@kdidiving.com
 tatkubinski@kdidiving.com

INVOICE

City of Wilmington
 1165 S Water St, Wilmington, IL 60481

Invoice # 7182
Invoice Date 06/23/2022
Due Date 06/23/2022

Item	Description	Unit Price	Quantity	Amount
Service	Day Rate Four Man Crew 05-26-2022	3980.00	1.00	3,980.00
Service	Mileage Round Trip	2.00	84.00	168.00
Service	Pumping Gear	480.00	1.00	480.00
Service				
Service	Day Rate Four Man Crew 06-02-2022	3980.00	1.00	3,980.00
	Mileage Round Trip	2.00	84.00	168.00
	Pumping Gear	480.00	1.00	480.00
 NOTES: ****Water strainer cleaning/sediment removal in Wilmington, IL on 05-26-2022-----06-02-2022****				
Subtotal				9,256.00
Total				9,256.00
Amount Paid				0.00
Balance Due				\$9,256.00



City of Wilmington

1165 S. Water Street ■ Wilmington, IL 60481-1633
Phone: 815-476-2175 ■ Fax: 815-476-9782 ■ www.wilmington-il.com

Date: July 8, 2023

To: Honorable Mayor Dietz and City Council Members

From: Nancy Gross, Finance Director

CC: Jeannine Smith, City Administrator
Joie Ziller, Deputy Clerk

RE: FYE '24 Annual Appropriations Ordinance

The Appropriations Ordinance is one of the most important ordinances adopted by the City of Wilmington Council every year. This ordinance provides the legal authority under which the City allocates money to specific spending activities. In addition, it establishes the City's legal spending limit for the fiscal year and serves as the basis for the property tax levy.

As a result, it is crucial for the City Council and the Administration to carefully anticipate and appropriate for all expenditures they wish to make during the fiscal year. Even so, one must remember that the appropriation ordinance only outlines those expenditures which can be made IF adequate revenues are available. It does not mean that sufficient revenues are actually on hand to pay for such expenditures.

The FYE '24 Appropriation Ordinance for the City of Wilmington is attached. You will see the anticipated revenues along with the *ESTIMATED* fund balances in one section. The expenditure section lists both the working budget numbers (that correspond to the discussions we have all had the last couple of months) and the appropriated expenditures in the second column.

The appropriated expenditures are computed at three (3) times the working budget amount. In addition, we have added back the project dollar amounts (vehicles, equipment, etc) that we took out of the budget to the appropriation number.

If, the City does not appropriate enough with this ordinance, we cannot spend it throughout the year. And, as the basis of the annual tax levy, the City will be restricted in what it can levy if the appropriations are not enough. On the flip side of that, it certainly does NOT mean that the City will be raising taxes in a similar increment.

Because it is not an easy task to amend this ordinance, and therefore the need for inflated numbers, the City will also use an "operating budget" as an every day management tool. The operating budget is intended to set a more realistic picture of the what the City can afford to accomplish throughout the year.

In summary, the Appropriation Ordinance specifies the maximum amount which can legally be spent, while the operating budget establishes the maximum amount which may be spent by legislative policy.

CITY OF WILMINGTON
WILL COUNTY, ILLINOIS

ORDINANCE NO. 23-07-18-01

AN ORDINANCE APPROPRIATING FOR ALL CORPORATE PURPOSES
FOR THE CITY OF WILMINGTON, WILL COUNTY, ILLINOIS
FOR THE FISCAL YEAR
BEGINNING MAY 1, 2023, AND ENDING APRIL 30, 2024

ADOPTED BY THE CITY COUNCIL
OF THE CITY OF WILMINGTON,
WILL COUNTY, ILLINOIS, THIS
18TH DAY OF JULY, 2023

PUBLISHED IN PAMPHLET FORM ON
THIS 19TH DAY OF JULY, 2023

Prepared by:
Deputy City Clerk
City of Wilmington
1165 South Water Street
Wilmington, IL 60481
815-476-2175

ORDINANCE NO. 23-07-18-01

AN ORDINANCE APPROPRIATING FOR ALL CORPORATE PURPOSES FOR THE CITY OF WILMINGTON, WILL COUNTY, ILLINOIS, FOR THE FISCAL YEAR BEGINNING MAY 1, 2023, AND ENDING APRIL 30, 2024

BE IT ORDAINED BY THE MAYOR AND THE CITY ALDERMEN OF THE CITY OF WILMINGTON, WILL COUNTY, ILLINOIS:

SECTION 1 - APPROPRIATION - That the amount hereinafter set forth, or so much thereof as may be authorized by law, and as may be needed or deemed necessary to defray all expenses and liabilities of the municipality be and the same are hereby appropriated for the corporate purposes of the city of Wilmington, Will County, Illinois, as hereinafter specified for the fiscal year beginning May 1, 2023, and ending April 30, 2024.

SECTION 2 - APPROPRIATION AND MAXIMUM AMOUNTS - That the appropriation herein made for any purposes shall be regarded as the maximum amounts to be expended under the respective appropriation accounts and shall not be construed as a commitment, agreement, obligation, or liability of the City of Wilmington, and such appropriation begin subject to further approval as to expenditure thereof by the City Council.

SECTION 3 - APPROPRIATION: OBJECTS AND PURPOSES - That the amount appropriated for each object and purpose, shall be as follows:

SECTION 4 - FILING WITH THE COUNTY CLERK - That the Clerk of the City of Wilmington shall file certified copies of the Ordinance with the County Clerk of Will County, Illinois, within thirty (30) days after its adoption.

SECTION 5 - REPEALER - All Ordinances or parts of Ordinances in conflict with any of the provisions of the ordinance shall be, and the same is hereby repealed.

SECTION 6 - SEVERABILITY - This Ordinance and every provision thereof, shall be considered severable. If any court of competent jurisdiction may find and declare a sentence, paragraph, provision, or section of this Ordinance is void or unconstitutional, the remaining words, phrases, clauses, sentences, paragraphs and provisions and parts of phrases, clauses, sentences, paragraphs, provisions, and sections not ruled void or unconstitutional shall continue in full force and effect.

SECTION 7 - EFFECTIVE DATE - This ordinance shall be in full force and effect from and after its passage, approval, and publication in pamphlet form as provided by law.

PASSED this 18th day of July 2023 with _____ members voting aye, 0 members voting nay, the Mayor voting N/A, with 0 members abstaining or passing and said vote being:

Kevin Kirwin _____
Dennis Vice _____
Leslie Allred _____
Todd Holmes _____

Ryan Jeffries _____
Ryan Knight _____
Jonathan Mietzner _____
Thomas Smith _____

Approved this 18th day of July, 2023



Attest:

Ben Dietz, Mayor

Joie Ziller, Deputy City Clerk

APPROPRIATION SUMMARY
FOR THE FISCAL YEAR ENDING APRIL 30, 2024

General Fund	
General Corporate	\$7,415,603
Police Protection	8,647,471
Payroll Taxes and Pension	561,788
Audit and Accounting	73,080
Police Pension	1,445,565
General Liability and Workers Comp Insurance	1,344,889
Water Operating, Maintenance and Repair Fund	6,029,132
Sewer Capital Projects Fund	5,026,750
Sewer Operating, Maintenance and Repair Fund	4,077,889
DFC Grant Fund - WCHC	120,640
Motor Fuel Tax Fund	2,925,000
ESDA - Emergency Services Fund	203,255
Debt Service Fund	2,601,750
Water Capital Project Fund	4,639,040
Building Deposit Holding Account Fund	470,774
Mobile Equipment Fund	945,000
Capital Projects Fund	2,307,514
Ridgeport #2 Tif Fund	19,845,912
TOTAL APPROPRIATIONS	<u><u>\$68,681,053</u></u>

APPROPRIATIONS

		<u>FYE 24</u>	<u>FYE 24</u>
		<u>BUDGET</u>	<u>APPROPRIATION</u>
FUND 01	General Corporate Fund		
<u>DEPT 01</u>	<u>Finance & Administration</u>		
01-01-6010	Wages -Finance & Adm.	\$276,207	\$828,622
	Mayor's Internship Program	3,000	9,000
01-01-6011	FICA Taxes	23,816	71,447
01-01-6012	City Engineer Services	0	0
01-01-6013	SUTA Tax	3,601	10,803
01-01-6014	IMRF	2,142	6,425
01-01-6015	OVERTIME WAGES	281	844
01-01-6050	Elected/Apptd Officials Wages	31,500	94,500
01-01-6320	Audit & Accounting Services	0	0
01-01-6335	Prof Fees - Computer R&M	44,000	132,000
01-01-6360	Dues, Subscrip. & Memberships	20,000	60,000
01-01-6380	Employee Health & Life Ins	31,689	95,066
01-01-6385	Retired Empl Health Ins/Dental	64,297	192,890
01-01-6390	Prof Fees - Engineering	15,000	45,000
01-01-6460	Legal Services	40,000	120,000
01-01-6510	Maintenance - Equipment	500	1,500
01-01-6640	Maint-Vehicles	0	0
01-01-6650	Notices/Legal Publications	1,000	3,000
01-01-6655	PUBLISHING/PRINTING	3,480	10,440
01-01-6665	Prof. Fee - Overweight Trucks	0	0
01-01-6670	Prof Fees - Other	17,000	51,000
01-01-6671	Payroll Processing	0	0
01-01-6675	Pace Bus Service	0	0
01-01-6727	Employee Health & Life Ins	0	0
01-01-6760	Telephone/Internet	17,000	51,000
01-01-6770	Training, Mtg & Travel Expense	8,000	24,000
01-01-6930	Gasoline & Oil	500	1,500
01-01-6960	Office Supplies	6,500	19,500
01-01-6965	Postage	1,000	3,000
01-01-6970	Oper Supplies and Tools	5,000	15,000
01-01-7110	Admin Misc Expense	0	0
01-01-7120	Donations	0	0
01-01-7125	WCHC - Community Matching	0	0
01-01-7130	Economic Develop Com Exp	0	0
01-01-7150	Mayor's Misc Exp	2,000	6,000
01-01-7151	Facade Improvement Program	50,000	150,000
01-01-7155	Community Festivals	0	0
01-01-7156	Catfish Days Expense	0	0
01-01-7157	City Beautification	15,000	45,000
01-01-7160	Misc Expense	2,000	6,000
01-01-7180	Police Commission Exp	0	0
01-01-7320	Equipment Purchase	64,000	192,000
01-01-7321	Leased Equipment Expense	8,300	24,900
01-01-7360	Expensed Equipment	1,000	3,000
01-01-7940	Service & Investment Fees	100	300
01-01-7950	Refunds	1,000	3,000
01-01-7951	Sales Tax Credit	0	0
01-01-7952	Utility Tax Credit/Job Inctv	0	0
01-01-8020	Transfers to Other Funds	59,500	178,500
01-01-8021	Contingency	80,000	240,000
	TOTAL FINANCE AND ADMINISTRATION APPROPRIATION	<u>898,413</u>	<u>2,695,238</u>
<u>DEPT 02</u>	<u>Public Grounds & Buildings</u>		
01-02-6010	Wages	52,787	158,362
01-02-6510	Maintenance - Equipment	10,000	30,000
01-02-6530	Maintenance - Grounds/Building	115,000	345,000
01-02-6531	Prof Fess - Janitorial	24,155	72,465
01-02-6670	Prof Fees - Other	35,000	105,000
01-02-6715	Rental of Buildings/Space	0	0
01-02-6760	Telephone/Internet	0	0

APPROPRIATIONS

		<u>FYE 24</u>	<u>FYE 24</u>
		<u>BUDGET</u>	<u>APPROPRIATION</u>
01-02-6810	Utilities	2,500	7,500
01-02-6970	Oper Supplies and Tools	2,500	7,500
01-02-7160	Misc Expense	0	0
01-02-7320	Equipment Purchases	0	0
01-02-8021	Contingency	30,000	90,000
TOTAL PUBLIC GROUNDS AND BUILDINGS APPROPRIATION		<hr/> 271,942	<hr/> 815,827
<u>DEPT 03</u>	<u>Police Dept</u>		
01-03-6010	Wages - WPD	1,551,462	4,654,386
01-03-6011	FICA Tax	160,000	479,999
01-03-6013	SUTA Tax	45,166	135,497
01-03-6014	IMRF	475	1,425
01-03-6015	Overtime Wages	96,739	290,218
01-03-6020	Part Time Wages	74,317	222,951
01-03-6030	Crossing Guard Wages	2,070	6,211
01-03-6035	Vacation/SickTime Buyout	151,774	455,322
01-03-6310	Prof Fees - Animal Control	1,000	3,000
01-03-6331	Community Service & Affairs	1,000	3,000
01-03-6335	Prof Fees - Computer R&M	27,000	81,000
01-03-6340	Prof Fees - Dispatch Svcs	210,022	630,065
01-03-6360	Dues, Subscrp. & Memberships	15,000	45,000
01-03-6380	Employee Health & Life Ins	232,364	697,093
01-03-6460	Legal Services	30,000	90,000
01-03-6510	Maintenance - Equipment	6,500	19,500
01-03-6640	Maint-Vehicles	15,000	45,000
01-03-6650	Notices/Legal Publications	1,300	3,900
01-03-6670	Prof Fees - Other	10,000	30,000
01-03-6671	K-9 Program Expenses	1,250	3,750
01-03-6672	DRONE GRANT EXPENDITURES	8,000	24,000
01-03-6673	RANGE GRANT EXPENDITURES	5,000	15,000
01-03-????	SPEED ENFORCEMENT GRANT EXP	5,000	15,000
01-03-6760	Telephone/Internet	30,000	90,000
01-03-6770	Training, Mtg & Travel Expense	25,000	75,000
01-03-6775	Grant Expenditures	0	0
01-03-6930	Gasoline & Oil	68,000	204,000
01-03-6960	Office Supplies	3,000	9,000
01-03-6965	Postage	1,000	3,000
01-03-6970	Oper Supplies and Tools	18,000	54,000
01-03-7010	Uniforms & Accessories	30,000	90,000
01-03-7160	Misc Expense	500	1,500
01-03-7320	Equipment Purchases	43,551	130,653
01-03-7321	Leased Equipment Expense	10,000	30,000
01-03-7360	Expensed Equipment	3,000	9,000
01-03-8020	Transfer to Other Funds	0	0
TOTAL POLICE APPROPRIATION		<hr/> 2,882,490	<hr/> 8,647,471
<u>Dept 04</u>	<u>Police Commission Board</u>		
01-04-6010	Wagaes	1,800	5,400
01-04-6011	FICA Taxes	0	0
01-04-6013	SUTA Taxes	0	0
01-04-6360	Dues	0	0
01-04-6460	Legal	0	0
01-04-6770	Training, Seminars	0	0
01-04-6775	Promotional Exams	0	0
01-04-6776	Candidate Poly/Psych	0	0
01-04-6777	Candidate Background Checks	0	0
01-04-7180	Police Commission Expenses	15,000	45,000
01-04-8021	Contingency	0	0
TOTAL POLICE COMMISSION BOARD APPROPRIATION		<hr/> 16,800	<hr/> 50,400

APPROPRIATIONS

		<u>FYE 24</u>	<u>FYE 24</u>
		<u>BUDGET</u>	<u>APPROPRIATION</u>
<u>DEPT 05</u>	<u>Public Works</u>		
01-05-6010	Wages - PW	230,873	692,619
	Mayor's Internship Program	1,033	3,100
01-05-6011	FICA Tax	17,741	53,223
01-05-6012	City Engineer Services	0	0
01-05-6013	SUTA Tax	3,500	10,500
01-05-6014	IMRF	2,280	6,839
01-05-6015	Overtime Wages	22,000	66,000
01-05-6020	Part Time Wages	40,000	120,000
01-05-6252	City Beautification	0	0
01-05-6335	Prof Fees - Computer R&M	2,500	7,500
01-05-6360	Dues, Subscrp. & Memberships	3,000	9,000
01-05-6380	Employee Health & Life InsU9c	109,000	327,000
01-05-6390	Prof Fees - Engineering	10,000	30,000
01-05-6440	Prof Fees - JULIE Locate	2,000	6,000
01-05-6460	Legal Services	0	0
01-05-6480	Maint-Bridges	6,000	18,000
01-05-6500	Maint-Curbs & Gutters	3,500	10,500
01-05-6510	Maintenance - Equipment	32,500	137,500
01-05-6530	Maintenance - Grounds/Building	0	0
01-05-6535	Maint-Parking Lots	0	0
01-05-6570	Maint-Sidewalks	3,000	9,000
01-05-6580	Maint-Storm Sewers	9,000	27,000
01-05-6590	Maint-Streets	32,000	96,000
01-05-6640	Maint-Vehicles	16,500	49,500
01-05-6650	Notices/Legal Publications	500	1,500
01-05-6670	Prof Fees - Other	500	1,500
01-05-6710	Rental of Equipment	15,000	45,000
01-05-6740	Street Light Electricity	110,000	330,000
01-05-6760	Telephone/Internet	8,661	25,982
01-05-6770	Training, Mtg & Travel Expense	4,500	13,500
01-05-6780	Tree and Weed Removal	10,000	30,000
01-05-6785	Mowing	0	0
01-05-6930	Gasoline & Oil	30,000	90,000
01-05-6960	Office Supplies	750	2,250
01-05-6965	Postage	200	600
01-05-6970	Oper Supplies and Tools	31,750	95,250
01-05-6983	Salt & Cinders	0	0
01-05-6990	Sign Replacement	6,000	18,000
01-05-7010	Uniforms & Accessories	4,500	13,500
01-05-7020	Vehicle Tags	0	0
01-05-7160	Misc Expense	0	0
01-05-7290	SPECIAL TOOL FUND EXPENSES	0	0
01-05-7320	Equipment Purchases	0	310,000
01-05-7321	Leased Equipment	0	0
01-05-7323	Equip Loan - Princ	0	0
01-05-7324	Equip Loan - Interest	0	0
01-05-7325	Equipment Loan	0	0
01-05-7350	New Streets/Sidewalks	0	0
01-05-7360	Expensed Equipment	10,000	30,000
01-05-8020	Transfers to Other Funds	0	0
01-05-8021	Contingency	0	0
	TOTAL PUBLIC WORKS APPROPRIATION	<u>778,788</u>	<u>2,686,363</u>
<u>DEPT 09</u>	<u>Payroll Taxes/Pension Dept</u>		
01-09-6011	FICA Taxes - GC	182,366	547,099
01-09-6014	IMRF - GC	4,896	14,689
	TOTAL PAYROLL TAXES/PENSION APPROPRIATION	<u>187,263</u>	<u>561,788</u>
<u>DEPT 10</u>	<u>Audit & Acctg Dept</u>		
01-10-6320	Prof Fees - Audit/Acctg	24,360	73,080

APPROPRIATIONS

		<u>FYE 24 BUDGET</u>	<u>FYE 24 APPROPRIATION</u>
01-10-6671	Prof Fees - PR Processing	0	0
TOTAL AUDIT & ACCOUNTING APPROPRIATION		<hr/> 24,360	<hr/> 73,080
<u>DEPT 13</u>	<u>Building Department</u>		
01-13-6010	Wages - Bldg	32,727	98,180
01-13-6011	FICA Tax	2,504	7,511
01-13-6012	City Engineer Services	0	0
01-13-6013	SUTA Tax	933	2,798
01-13-6335	Prof Fees - Computer R&M	500	1,500
01-13-6337	Consulting Fee - Engineering & Inspection	105,000	315,000
01-13-6360	Dues, Subscrp. & Memberships	4,500	13,500
01-13-6380	Employee Health & Life Ins	12,529	37,587
01-13-6460	Legal Services	100	300
01-13-6760	Telephone/Internet	500	1,500
01-13-6770	Training, Mtg & Travel Expense	1,000	3,000
01-13-6960	Office Supplies	500	1,500
01-13-6965	Postage	100	300
01-13-6970	Oper Supplies and Tools	1,000	3,000
01-13-7160	Misc Expense	0	0
01-13-7360	Expensed Equipment	500	1,500
TOTAL BUILDING APPROPRIATION		<hr/> 162,392	<hr/> 487,175
<u>DEPT 14</u>	<u>Planning & Zoning</u>		
01-14-6010	Wages - P & Z	2,295	6,885
01-14-6011	FICA Tax	60	180
01-14-6012	City Engineer Services	0	0
01-14-6013	SUTA Tax	12	36
01-14-6014	IMRF	0	0
01-14-6308	Employee Health & Life Ins	0	0
01-14-6337	Consulting Fee	0	0
01-14-6338	Consulting Fees - Developers	0	0
01-14-6380	Employee Health & Life Ins	0	0
01-14-6390	Prof Fees - Engineering	1,000	3,000
01-14-6391	Prof Fees - Engineering - DEV	0	0
01-14-6393	Deer Creek Capital Imprv Exp	0	0
01-14-6460	Legal Services	10,000	30,000
01-14-6461	Legal Services - Developers	0	0
01-14-6462	Will County Sheriff Services	0	0
01-14-6500	Prof Fees - Comprehensive Plan	100,000	300,000
01-14-6650	Notices/Legal Publications	1,000	3,000
01-14-6960	Office Supplies	500	1,500
01-14-6965	Postage	500	1,500
01-14-7160	Misc Expense	0	0
TOTAL PLANNING & ZONING APPROPRIATION		<hr/> 115,367	<hr/> 346,101
<u>DEPT 15</u>	<u>Police Pension</u>		
01-15-6320	Audit & Accounting Services	5,830	17,490
01-15-6685	Police Pension Contribution	476,025	1,428,075
01-15-8020	Transfer to Other Funds	0	0
TOTAL POLICE PENSION APPROPRIATION		<hr/> 481,855	<hr/> 1,445,565
<u>DEPT 20</u>	<u>Catfish Days Dept</u>		
01-20-7156	Catfish Days Expenses	35,000	105,000
TOTAL CATFISH DAYS APPROPRIATION		<hr/> 35,000	<hr/> 105,000
<u>DEPT 21</u>	<u>Economic Development Dept</u>		
01-21-7130	Economic Development Expenses	2,500	7,500

APPROPRIATIONS

		<u>FYE 24</u> <u>BUDGET</u>	<u>FYE 24</u> <u>APPROPRIATION</u>
TOTAL ECONOMIC DEVELOPMENT APPROPRIATION		2,500	7,500
<u>DEPT 22</u>	<u>Community Fesitvals (not CFDs) Dept</u>		
01-22-7130	Commumity Fesitvals (not CFDs) Exp	22,000	66,000
TOTAL COMMUNITY FESTIVALS (not CFDs) APPROPRIATION		22,000	66,000
<u>Dept 25</u>	<u>Gen Liability/W. Comp/Eqp Ins</u>		
01-25-6470	Prop. Equip & Liab. Ins	327,021	981,062
01-25-6690	W/Comp Ins	121,276	363,827
01-25-6691	Liability Ins. Dedctible	0	0
01-25-7160	Misc Expense (Min-Max)	0	0
01-25-8021	Contingency	0	0
TOTAL GENERAL LIABILITY/WORK COMP/EQUIP INS APPROPRIATION		448,296	1,344,889
<u>Dept 95</u>	<u>Police Savings - DUI</u>		
01-95-xxxx	Expenditures	0	25,000
TOTAL POLICE SAVINGS - DUI APPROPRIATION		0	25,000
<u>Dept 96</u>	<u>Police Savings - Drug</u>		
01-96-xxxx	Expenditures	0	25,000
TOTAL POLICE SAVINGS - DRUG APPROPRIATION		0	25,000
<u>Dept 97</u>	<u>Police Savings - Police Vehicle</u>		
01-97-xxxx	Expenditures	0	1,000
TOTAL POLICE SAVINGS - POLICE VEHICLE APPROPRIATION		0	1,000
<u>Dept 98</u>	<u>Police Savings - Impound</u>		
01-98-xxxx	Expenditures	0	5,000
TOTAL POLICE SAVINGS - IMPOUND APPROPRIATION		0	5,000
<u>Dept 99</u>	<u>Police Savings - Warrants</u>		
01-99-xxxx	Expenditures	0	100,000
TOTAL POLICE SAVINGS - WARRANTS APPROPRIATION		0	100,000
TOTAL GENERAL CORPORATE FUND APPROPRIATION		6,327,466	19,488,397
FUND 02	WATER OPERATING, MAINTENANCE AND REPAIR FUND		
<u>Dept 21</u>	<u>Water</u>		
02-21-6010	Wages - Water	622,122	1,866,366
	Mayor's Internship Program	1,033	3,100
02-21-6011	FICA Taxes - Water Dept	46,425	139,275
02-21-6012	City Engineer Wages	0	0
02-21-6013	SUTA Taxes - Water Dept	3,300	9,900
02-21-6014	IMRF - Water Dept	4,083	12,250
02-21-6015	Overtime Wages	34,149	102,447
02-21-6020	Part Time Wages	0	0
02-21-6335	Prof Fees - Computer R&M	15,000	45,000
02-21-6337	Prof Fees - Consulting	40,000	120,000
02-21-6360	Dues,Subscrip. & Memberships	2,500	7,500
02-21-6380	Employee Health & Life Ins	90,657	271,972
02-21-6390	Prof Fees - Engineering	0	0
02-21-6460	Legal Services	0	0
02-21-6470	Prop, Equip & Liab Ins	109,007	327,021
02-21-6510	Maintenance - Equipment	40,000	120,000
02-21-6520	Maint-Well	7,000	21,000

APPROPRIATIONS

		<u>FYE 24 BUDGET</u>	<u>FYE 24 APPROPRIATION</u>
02-21-6530	Maintenance - Site Grnds/Bldg	45,000	135,000
02-21-6540	Maint-Distribution	27,000	81,000
02-21-6610	Maint-Site Process Mains	10,000	30,000
02-21-6620	Maint-Water Meters	1,000	3,000
02-21-6625	Maint-BstrStn /Towers	2,500	7,500
02-21-6640	Maint-Vehicles	3,000	9,000
02-21-6650	Notices/Legal Publications	500	1,500
02-21-6670	Prof Fees - Other -Labs	15,000	45,000
02-21-6671	Testing & Calibration	16,000	48,000
02-21-6674	Prof Fees - Printing & Duplica	2,500	7,500
02-21-6690	W/Comp Ins	25,317	75,950
02-21-6710	Rental of Equipment	0	0
02-21-6730	Lime/Sludge Disposal	60,000	180,000
02-21-6760	Telephone/Internet	5,500	16,500
02-21-6770	Training, Mtg & Travel Expense	4,000	12,000
02-21-6810	Utilities	50,000	150,000
02-21-6930	Gasoline & Oil	5,900	17,700
02-21-6960	Office Supplies	2,000	6,000
02-21-6965	Postage	1,500	4,500
02-21-6970	Oper Supplies and Tools	10,000	30,000
02-21-7010	Uniforms & Accessories	3,200	9,600
02-21-7030	Water Treatment Chemicals	115,739	347,217
02-21-7160	Misc Expense	0	0
02-21-7320	Equipment Purchases	55,000	165,000
02-21-7321	Leased Equipment Expense	1,500	4,500
02-21-7322	Water Main Ext - IEPA Project	0	0
02-21-7323	IEPA Laon Payments Rt 53 WtrMn	0	0
02-21-7332	Fire Hydrants	0	0
02-21-7340	Meters	0	0
02-21-7360	Expensed Equipment	0	0
02-21-7928	Wtr IEPA Loan#2 Princ	0	0
02-21-7929	Wtr IEPA Loan#2 - Interest	0	0
02-21-7932	Wtr IEPA Loan#1 Princ	0	0
02-21-7934	Wtr IEPA Loan#1 Interest	0	0
02-21-7940	Service Investment Fees	0	0
02-21-7950	Refunds	500	1,500
02-21-8020	Transfers to Other Funds	0	0
02-21-8021	Contingency	10,000	30,000
TOTAL WATER OPERATING APPROPRIATION		<u>1,487,932</u>	<u>4,463,797</u>
 <u>Dept 23</u> <u>Garbage Service</u>			
02-23-6420	Garbage Collection Expense	521,778	1,565,334
TOTAL GARBAGE COLLECTION APPROPRIATION		<u>521,778</u>	<u>1,565,334</u>
TOTAL WATER OPERATING, MAINTENANCE & REPAIR APPROPRIATION		<u>2,009,711</u>	<u>6,029,132</u>
 FUND 03 SEWER CAPITAL PROJECTS FUND			
03-00-6012	City Engineer Services	0	0
03-00-6014	City Engineering Services	0	0
03-00-6380	Employee Health & Life Ins	0	0
03-00-6390	Prof Fees - Engineering	175,000	525,000
03-00-6460	Legal Services	0	0
03-00-6510	Maintenance - Equipment	15,000	45,000
03-00-6670	Prof Fees - Other	0	0
03-00-7160	Misc Expense	0	0
03-00-7165	Sewer Line Rte 53 Recap Expense	0	0
03-00-7316	Sewer Plant Construction	0	0
03-00-7318	Sewer Plant Expansion	0	0
03-00-7320	CDBG - Will County	0	0
03-00-7320	Equipment Purchases	0	145,000
03-00-7325	Loan - Capital Improvements	0	0

APPROPRIATIONS

		FYE 24 BUDGET	FYE 24 APPROPRIATION
03-00-7420	Sewer Main Extensions	0	0
03-00-7430	Sewer Collection Line Upgrade	120,000	360,000
03-00-7450	Misc. Other Capital Projects	400,000	1,200,000
03-00-7935	IEPA ARS Bnd Series '20 Prin	735,000	2,205,000
03-00-7936	IEPA ARS Bnd Series '20 Int	131,775	395,325
03-00-7940	Service & Investment Fees	475	1,425
03-00-8020	Transfers to Other Funds	0	0
03-00-8021	Contingency	50,000	150,000
03-00-8022	Bond Amortization Expense	0	0
TOTAL SEWER CAPITAL PROJECTS FUND APPROPRIATION		1,627,250	5,026,750

FUND 04 SEWER OPERATING, MAINTENANCE & REPAIR FUND

04-00-6001	Depreciation	0	0
04-00-6010	Wages - Sewer	414,246	1,242,738
	Mayor's Internship Program	1,033	3,100
04-00-6011	FICA Taxes - Sewer Dept	31,769	95,307
04-00-6013	SUTA Taxes - Sewer Dept.	2,902	8,706
04-00-6014	IMRF - Sewer Dept	3,735	11,204
04-00-6015	Overtime Wages	17,500	52,500
04-00-6020	Part Time Wages	0	0
04-00-6335	Prof Fees - Computer R&M	17,410	52,230
04-00-6360	Dues, Subscrp. & Memberships	2,500	7,500
04-00-6380	Sewer Dept. Health & Life Ins.	83,387	250,160
04-00-6390	Prof Fees - Engineering	19,000	57,000
04-00-6460	Legal Services	0	0
04-00-6470	Prop, Equip & Liab Ins	101,852	305,557
04-00-6510	Maintenance - Equipment	32,500	97,500
04-00-6530	Maintenance - Grounds/Building	224,000	672,000
04-00-6560	Maintenance Sewers Collection	30,000	90,000
04-00-6561	Maintenance Sewers - Process	57,500	172,500
04-00-6640	Maint-Vehicles	4,000	12,000
04-00-6650	Notices/Legal Publications	500	1,500
04-00-6670	Prof Fees - Other	2,500	7,500
04-00-6671	Testing & Calibration	43,000	129,000
04-00-6674	Prof Fees - Printing & Duplica	3,000	9,000
04-00-6690	W/Comp Ins	21,660	64,980
04-00-6710	Rental of Equipment	0	0
04-00-6730	Sewer Sludge Disposal	30,779	92,336
04-00-6760	Telephone/Internet	5,000	15,000
04-00-6770	Training, Mtg & Travel Expense	5,000	15,000
04-00-6810	Utilities - Electric & Gas	67,024	201,071
04-00-6930	Gasoline & Oil	7,000	21,000
04-00-6960	Office Supplies	5,000	15,000
04-00-6965	Postage	1,500	4,500
04-00-6970	Oper Supplies & Tool	23,000	69,000
04-00-6985	Sewer Chemicals	81,000	243,000
04-00-7010	Sewer Dept Uniforms	2,500	7,500
04-00-7160	Misc Expense	0	0
04-00-7320	Equipment Purchases	17,500	52,500
04-00-7321	Leased Equipment Expense	0	0
04-00-7360	Expensed Equipment	0	0
04-00-7932	IEPA Loan Principle Pymt-WWTP	0	0
04-00-7934	IEPA Loan Interest Pymt-WWTP	0	0
04-00-7935	IEPA ARS Bnd Series '20 Prin.	0	0
04-00-7936	IEPA ARS Bnd Series '20 Int.	0	0
04-00-7940	Service & Investment Fees	0	0
04-00-7950	Refunds	0	0
04-00-8020	Transfers to Other Funds	0	0
04-00-8021	Contingency	0	0
TOTAL SEWER OPERATING FUND APPROPRIATION		1,359,296	4,077,889

APPROPRIATIONS

		<u>FYE 24</u>	<u>FYE 24</u>
		<u>BUDGET</u>	<u>APPROPRIATION</u>
FUND 05	DFC FEDERAL GRANT FUND - WCHC		
05-00-6010	Personnel Services	0	0
05-00-6320	Prof Fees - Audit/Acctg	3,600	10,800
05-00-6510	Maintenance - Equipment	0	0
05-00-6530	Buildings, Utilities, Services	0	0
05-00-6670	DFC Federal Grant Expenditures	36,613	109,840
05-00-6715	Building Rental, Utilities	0	0
05-00-6725	Safety Training/Materials	0	0
05-00-6727	Employee Health Prevention	0	0
05-00-6770	DFC Training & Travel Expenses	0	0
05-00-6930	Gasoline & Oil	0	0
05-00-6960	Office Supplies	0	0
05-00-6970	Oper Supplies and Tools	0	0
05-00-6980	Advertising/Marketing	0	0
05-00-7160	Misc Expense	0	0
05-00-7360	Computers, Software & Equipmnt	0	0
05-00-8020	Transfers to Other Funds	0	0
	TOTAL DFC FEDERAL GRANT FUND - WCHC APPROPRIATION	<u>40,213</u>	<u>120,640</u>
FUND 06	MOTOR FUEL TAX FUND		
06-00-6390	Prof Fees - Engineering	0	0
06-00-6595	MFT Projects Current Year	975,000	2,925,000
06-00-6596	Misc. MFT Projects - Prior Years	0	0
06-00-6983	Salt & Cinders	0	0
06-00-7940	Service & Investment Fees	0	0
06-00-8021	Contingency	0	0
	TOTAL MOTOR FUEL TAX FUND APPROPRIATION	<u>975,000</u>	<u>2,925,000</u>
FUND 07	ESDA - EMERGENCY SERVICES		
07-00-6010	Wages - ESDA	15,000	45,000
07-00-6011	FICA Tax	1,200	3,600
07-00-6013	SUTA Tax	550	1,650
07-00-6335	Prof Fees - Computer R&M	0	0
07-00-6340	Prof Fees - Dispatch Svc	4,500	13,500
07-00-6360	Dues Subscrip. & Memberships	2,100	6,300
07-00-6510	Maintenance - Equipment	2,000	6,000
07-00-6550	Maint - Radios & Pagers	800	2,400
07-00-6640	Maint - Vehicles	3,000	9,000
07-00-6650	Notices/Legal Publication	0	0
07-00-6670	Prof Fees - Other	1,500	4,500
07-00-6760	Telephone/Internet	10,000	30,000
07-00-6770	Training, Mtg & Travel Expense	1,500	4,500
07-00-6800	IPRA Drill Expense	0	0
07-00-6817	Subscription Weather Service	200	600
07-00-6930	Gasoline & Oil	2,000	6,000
07-00-6960	Office Supplies	500	1,500
07-00-6965	Postage	0	0
07-00-6970	Oper Supplies and Tools	5,000	15,000
07-00-7160	Misc Expense	0	0
07-00-7320	Equipment Purchases	17,902	53,705
07-00-7321	Leased Equipment Expense	0	0
07-00-7360	Expensed Equipment	0	0
07-00-8020	Transfers to Other Funds	0	0
07-00-8021	Contingency	0	0
	TOTAL ESDA - EMERGENCY SERVICES FUND APPROPRIATION	<u>67,752</u>	<u>203,255</u>

APPROPRIATIONS

		<u>FYE 24 BUDGET</u>	<u>FYE 24 APPROPRIATION</u>
FUND 12	DEBT SERVICE FUND		
12-00-7160	Misc Expense	0	0
12-00-7920	SSA 2008 Series Bond - Principal	0	0
12-00-7922	Series 2020 ARS Bond Principal	735,000	1,205,000
12-00-7923	Series 2020 ARS Bond Interest	131,775	395,325
12-00-7930	SSA 2008 Series Boind - Interest	0	0
12-00-7931	Series 2015 ARS Bond Principla	0	0
12-00-7933	Series 2015 ARS Bonds Interest	0	0
12-00-7935	Series 2006 Principal	0	0
12-00-7937	Series 2006 Interest	0	0
12-00-7938	Series 2017 Rollover GO Principal	0	0
12-00-7939	Series 2017 GO Rollover Interest	0	0
12-00-7940	Service & Investment Fees	475	1,425
12-00-7941	Series 2018 rollover GO Principal	0	0
12-00-7942	Series 2018 GO Rollover Interest	0	0
12-00-8020	Transfers to Other Funds	0	0
12-00-8021	Contingency	0	1,000,000
TOTAL DEBT SERVICE FUND APPROPRIATION		<u>867,250</u>	<u>2,601,750</u>
FUND 17	WATER CAPITAL PROJECTS FUND		
17-00-6010	Meter FF Replacement Salary	0	0
17-00-6012	City Engineer Services	0	0
17-00-6014	IMRF	0	0
17-00-6337	Prof Fees - Consulting	5,500	16,500
17-00-6380	Employee Health & Life	0	0
17-00-6390	Prof Fees - Engineering	90,000	270,000
17-00-6460	Legal Services	500	1,500
17-00-6510	Maintenance - Equipment	6,500	19,500
17-00-6540	Maint - Distribution	0	0
17-00-6620	Maint - Water Meters	170,000	510,000
17-00-6625	Maint -	0	0
17-00-6670	Prof Fees - Other	0	0
17-00-7160	Misc Expense	0	0
17-00-7165	Water Line Rte 53 Recap Expens	0	0
17-00-7320	Equipment Purchases	186,900	750,700
17-00-7321	Capital Equipment Purchases	0	0
17-00-7322	Water Capital Projects	562,000	2,860,000
17-00-7323	IEPA Rt 53 WaterMain Ext Loan	0	0
17-00-7325	Loan - Capital Improvements	0	0
17-00-7400	CDBG Water Main Rplmnt	0	0
17-00-7928	IEPA Loan #2 Principle Pymt	31,126	93,378
17-00-7929	IEPA Loan #2 Interest Pymt	9,616	28,848
17-00-7932	IEPA Loan #1 Principle Pymt - WTP	25,590	76,770
17-00-7934	IEPA Loan #1 Interest Pymt - WTP	2,948	8,844
17-00-7940	Service Investment Fees	1,000	3,000
17-00-8020	Transfer to Other Funds	0	0
17-00-8021	Contingency	0	0
TOTAL WATER CAPITAL PROJECTS FUND APPROPRIATION		<u>1,091,680</u>	<u>4,639,040</u>
FUND 20	BUILDING DEPOSIT HOLDING ACCOUNT FUND		
20-00-6338	Consulting Fees - Developers	133,527	400,581
20-00-6461	Legal Services - Developers	23,398	70,193
20-00-7160	Miscellaneous Expense	0	0
20-00-7170	Distributions	0	0
20-00-8020	Transfer to Other Funds	0	0
TOTAL BUILDING DEPOSIT HOLDING ACCOUNT FUND APPROPRIATION		<u>156,925</u>	<u>470,774</u>
FUND 21	MOBILE EQUIPMENT FUND		
21-00-7410	WPD MEF Vehicle Purchase	100,000	300,000
21-00-7411	Public Works Vehicle Purchase	0	310,000

APPROPRIATIONS

		<u>FYE 24 BUDGET</u>	<u>FYE 24 APPROPRIATION</u>
21-00-7412	ESDA MEF Vehicle Purchase	0	0
21-00-7415	Water MEF Vehicle Purchase	0	190,000
21-00-7416	Sewer MEF Vehicle Purchase	0	145,000
21-00-8020	Transfer to Other Funds	0	0
TOTAL MOBILE EQUIPMENT APPROPRIATION		<u>100,000</u>	<u>945,000</u>
FUND 24	CAPITAL PROJECT FUND		
24-00-6390	Prof Fees - Engineering	0	0
24-006450	Landfill Closure Expenses	0	0
24-00-6670	Prof Fees - Other	0	0
24-00-7130	Openlands/OSLAD	0	0
24-00-7211	Community Build Project	0	0
24-00-7212	Developer Project - Buck	0	0
24-00-7310	KKK Rvr Dam Legal Survey	0	0
24-00-7311	NI Parking Lot-Phase 1	0	0
24-00-7312	Safe Routes Schools Project	0	0
24-00-7313	WPD Facility-Ridge Bldg Project	0	0
24-00-7314	Misc Land Building Purchase	791	2,373
24-00-7315	KKK St./Forked Creek Bridge Pr	275,116	825,348
24-00-7321	Capital Equipment Purchases	0	0
24-00-7414	Ridgeport W/S Extension Projec	0	0
24-00-7415	USCS/IDOT Rte 53/Peotone Rd	0	0
24-00-7440	IDOT Rt 53/N River Rd Project	39,018	117,055
24-00-7448	Traffic Signals Rt53/Arsenal	0	0
24-00-7449	S Arsenal/Rte 53 EDP/IDOT	0	0
24-00-7450	Misc Other Capital Projects	60,000	180,000
24-00-7940	Service & Investment Fees	0	0
24-00-8020	Transfers to Other Funds	384,246	1,152,738
24-00-8021	Contingency	10,000	30,000
TOTAL CAPITAL PROJECT APPROPRIATION		<u>769,171</u>	<u>2,307,514</u>
FUND 25	RIDGEPORT TIF #2 FUND		
25-00-6320	AUDIT & ACCOUNTING SERVICES	500	1,500
25-00-6470	PROP, EQUIP & LIAB INSURANCE	0	0
25-00-6690	W/COMP INS	0	0
25-00-6790	UNEMPLOYMENT INSURANCE - SUTA	0	0
25-00-7160	MISC EXPENSE	0	0
25-00-7170	TIF #2 DISTRIBUTIONS	6,554,804	19,664,412
25-00-7171	TIF - PROF FEES/ADMIN	25,000	75,000
25-00-7172	TIF - ADMIN OVERAGE EXPENSE	35,000	105,000
25-00-7173	TIF - PROPERTY ACQUIS/ASSEMBLY	0	0
25-00-7175	TIF - PUBLIC WORKS/IMPROVEMENTS	0	0
25-00-7178	TIF - FINANCING INT EXPENSE	0	0
25-00-7940	SERVICE & INVESTMENT FEES	0	0
25-00-8020	TRANSFERS TO OTHER FUNDS	0	0
TOTAL RIDGEPORT TIF #2 APPROPRIATION		<u>6,615,304</u>	<u>19,845,912</u>
GRAND TOTAL CITY OF WILMINGTON ESTIMATED EXPENDITURES		<u>\$22,007,018</u>	<u>\$68,681,053</u>

ESTIMATED REVENUES

Fund 01: GENERAL CORPORATE

Estimated Fund Balance at May 1, 2023

\$1,989,263

Dept. 00

Property Taxes - Corporate	\$382,945
Property Taxes - Public Act 102 Adj	6,799
State Sales Tax	1,411,017
Telecom/Excise Tax	63,869
State Use Tax	232,224
State Replacement Tax	177,613
Cannabis Tax	10,139
State Income Tax	880,186
State Pull Tab/Games Tax	2,055
Video Gaming Tax	234,869
ComEd	430,000
Nicor	235,000
Cable TV Franchise Fee	87,000
Hotel/Motel Tax	8,400
Business Registration Fee	2,018
Economic Development Fee	10,779
Liquor License	22,690
Golf Cart License	1,550
Restaurant License	150
Bakery License	60
Food Truck Permit	475
Food Dealer Fee	100
Tobacco License	300
Convenience Stores Fee	100
Truck Permits - Overweight	61,990

Total Dept. 00 Revenue 4,262,326

Dept. 02 - Public Buildings and Grounds

INSURANCE PROCEEDS	46,417
Total Dept. 02 Revenue	<u>46,417</u>

Dept. 03 - Police

PROPERTY TAXES	262,148
ORDINANCE VIOLATION TICKET FEES	64,937

GRANTS - STATE	5,000
OTHER REIMBURSEMENTS	500
DEVELOPER REIMBURSEMENTS	126,293

Total Dept. 03 Revenue	<u><u>458,878</u></u>
------------------------	-----------------------

Dept. 05 - Public Works

PROPERTY TAXES - TWP ROAD & BRIDGE	97,461
GRANTS - OTHER	10,000

Total Dept. 05 Revenue	<u><u>107,461</u></u>
------------------------	-----------------------

Dept. 09 - Payroll Taxes and Pension

PROPERTY TAXES - SOCIAL SECURITY	76,526
PROPERTY TAXES - IMRF	20,554

Total Dept. 09 Revenue	<u><u>97,080</u></u>
------------------------	----------------------

Dept. 10 - Audit & Accounting

PROPERTY TAXES - AUDIT	7,431
------------------------	-------

Total Dept. 10 Revenue	<u><u>7,431</u></u>
------------------------	---------------------

Dept. 13 - Building

License Fee - Contractor Registration	10,100
Permit Fees	1,028,000
Building Inspection Fees	105,000

Total Dept. 13 Revenue	<u><u>1,143,100</u></u>
------------------------	-------------------------

Dept. 15 - Police Pension

PROPERTY TAXES - POLICE PENSION	476,073
---------------------------------	---------

Total Dept. 15 Revenue	<u><u>476,073</u></u>
------------------------	-----------------------

Dept. 20 - Catfish Days

DONATIONS/SPONSORSHIPS	35,000
------------------------	--------

	Total Dept. 20 Revenue	<u>35,000</u>
<u>Dept. 22 - Community Festivals (not CFDs)</u>		
DONATIONS		15,000
	Total Dept. 22 Revenue	<u>15,000</u>
<u>Dept. 25 - General Liability/W.Comp/Equip Ins</u>		
PROPERTY TAXES - TORT/LIABILITY		43,481
PROPERTY TAXES - WORKERS COMP		43,322
	Total Dept. 25 Revenue	<u>86,803</u>
TOTAL REVENUES FOR GENERAL FUND		<u>6,725,570</u>
Estimated Total Funds Available for General Fund		<u>\$8,714,833</u>

Fund 02: WATER OPERATING, MAINTENANCE & REPAIR

Estimated Fund Balance at May 1, 2023 **(\$170,666)**

<u>Dept. 21 - Water Operating</u>		
WATER SERVICE FEES		1,018,721
WATER METER FEES		8,935
I-HYDRANT FEES		2,900
INTEREST INCOME		48,991
OTHER INCOME - MISCELLANEOUS		6,850
		<u>1,086,397</u>
<u>Dept. 23 - Garbage Collection</u>		
GARBAGE COLLECTION FEES		481,804
TOTAL REVENUES FOR WATER OPERATING		<u>1,568,201</u>
Estimated Total Funds Available for WATER O,M&R FUND		<u>\$1,397,535</u>

FUND: 03 - SEWER CAPITAL PROJECTS

Estimated Fund Balance at May 1, 2023	\$2,468,425
WWTP DEBT SERVICE REVENUE	933,157
SEWER CAPACITY USER FEE	282,520
SEWER COLLECTION SYSTEM MAINTENANCE FEE	6,120
PENALTY FEE	38,513
INTEREST INCOME	2,715
TOTAL REVENUES FOR SEWER CAPITAL PROJECTS	<u>1,263,025</u>

Estimated Total Funds Available for SEWER CAPITAL FUND **\$3,731,450**

FUND: 04 - SEWER OPERATING, MAINTENANCE & REPAIR

Estimated Fund Balance at May 1, 2023	\$1,224,386
SEWER SERVICE FEES	929,524
INTEREST INCOME	11,556
TOTAL REVENUES FOR SEWER OPERATING	<u>941,080</u>

Estimated Total Funds Available for SEWER O,M&R FUND **\$2,165,466**

FUND: 05 - DFC FEDERAL GRANT - WCHC

Estimated Fund Balance at May 1, 2023	\$40,213
DFS FEDERAL GRANT FUNDS	0
TOTAL REVENUES FOR DFC FEDERAL GRANT	<u>0</u>

Estimated Total Funds Available for DFC FEDERAL GRANT - WCHC **\$40,213**

FUND: 06 - MOTOR FUEL TAX

Estimated Fund Balance at May 1, 2023	\$901,245
MFT STATE ALLOTMENTS	132,368
TRANSPORTATION RENEWAL ALLOTMENTS	108,296
INTEREST INCOME	1,000
HIGH GROWTH CITIES	8,400

TOTAL REVENUES FOR MOTOR FUEL TAX	<u>250,064</u>
--	-----------------------

Estimated Total Funds Available for MOTOR FUEL TAX FUND	<u><u>\$1,151,309</u></u>
--	----------------------------------

FUND: 07 - ESDA

Estimated Fund Balance at May 1, 2023	(\$3,378)
--	------------------

PROPERTY TAXES - CIVIL DEFENSE	1,265
REP GRANT	13,722

TOTAL REVENUES FOR ESDA	<u>14,987</u>
--------------------------------	----------------------

Estimated Total Funds Available for ESDA FUND	<u><u>\$11,609</u></u>
--	-------------------------------

FUND: 12 - DEBT SERVICE

Estimated Fund Balance at May 1, 2023	\$584,199
--	------------------

TRANSFERS FROM OTHER FUNDS	867,250
----------------------------	---------

TOTAL REVENUES FOR DEBT SERVICE	<u>867,250</u>
--	-----------------------

Estimated Total Funds Available for DEBT SERVICE FUND	<u><u>\$1,451,449</u></u>
--	----------------------------------

FUND: 17 - WATER CAPITAL PROJECTS

Estimated Fund Balance at May 1, 2023	\$ 1,615,633
--	---------------------

METER REPLACEMENT PROGRAM FEES	55,865
WATER PLANT DEBT SERVICE FEES	240,398
PENALTY FEES	33,553
WATER CAPACITY USER FEE	70,870
INTEREST INCOME	9,876
GRANTS	40,000

TOTAL REVENUES FOR WATER CAPITAL PROJECTS	<u>450,562</u>
--	-----------------------

Estimated Total Funds Available for WATER CAPITAL FUND	<u><u>\$2,066,195</u></u>
---	----------------------------------

FUND: 20 - BUILDING DEPOSIT

Estimated Fund Balance at May 1, 2023	\$43,674
DEVELOPER DEPOSITS	156,925
TOTAL REVENUES FOR BUILDING DEPOSIT	<u>156,925</u>
Estimated Total Funds Available for BUILDING DEPOSIT FUND	<u><u>\$200,599</u></u>

FUND: 21 - MOBILE EQUIPMENT FUND

Estimated Fund Balance at May 1, 2023	(\$31,604)
RIDGE WPD VEHICLE/EQUIPMENT CONTRIBUTION	100,000
TRANSFERS IN FROM OTHER FUNDS	0
TOTAL REVENUES FOR MOBILE EQUIPMENT FUND	<u>100,000</u>
Estimated Total Funds Available for MOBILE EQUIPMENT FUND	<u><u>\$68,396</u></u>

FUND: 24 - CAPITAL PROJECT FUND

Estimated Fund Balance at May 1, 2023	-\$1,022,908
GRANTS	233,093
INTEREST INCOME	4,100
TRANSFERS IN FROM OTHER FUNDS	0
TOTAL REVENUES FOR CAPITAL PROJECT	<u>237,193</u>
Estimated Total Funds Available for CAPITAL PROJECT FUND	<u><u>-\$785,715</u></u>

FUND: 25 - RIDGEPORT #2 TIF

Estimated Fund Balance at May 1, 2023	\$364,099
PROPERTY TAXES - RIDGEPORT TIF	6,579,804
INTEREST INCOME	375

OTHER REIMBURSEMENTS	35,125
TOTAL REVENUES FOR RIDGEPORT #2 TIF	<u>6,615,304</u>
Estimated Total Funds Available for RIDGEPORT #2 TIF FUND	<u>\$6,979,403</u>
GRAND TOTAL CITY OF WILMINGTON ESTIMATED REVENUES	<u>\$19,190,161</u>
ESTIMATED TOTAL FUNDS AVAILABLE FOR CITY OF WILMINGTON	<u>\$27,192,742</u>

**This Instrument Was Prepared By,
And After Recording Return To:**

Bryan M. Wellner
Mahoney, Silverman & Cross, LLC
822 N. 129th Infantry Drive, Suite 100
Joliet, IL 60435

SIGNAGE EASEMENT AGREEMENT

(Southwest Corner of Baltimore Street at Water Street)

THIS SIGNAGE EASEMENT AGREEMENT (this “**Agreement**”) is made as of the ___ day of _____, 2023, by and between KENNETH W FREY (“**Grantor**”) and the CITY OF WILMINGTON, an Illinois Municipal Corporation (“**Grantee**”).

RECITALS:

A. Grantor is the owner of the parcel of real estate located at 102 S. Water Street, Wilmington, Will County, Illinois, PIN No. 03-17-25-314-002-0000, and legally described on **Exhibit A** (hereinafter referred to as the “**Property**”).

B. The City of Wilmington was awarded a grant for a project that includes a wall mural to be installed on Route 66 at the intersection of Baltimore Street and Water Street, depicted in Exhibit B (hereinafter referred to the “**Wall Mural**”);

C. Given the location of the Grantor’s business and building, and the wall space on Grantor’s building, Grantee requested and Grantor is willing to provide to Grantee a signage easement to install the Wall Mural, in accordance with the terms and conditions hereinafter set forth.

NOW, THEREFORE, Grantor and Grantee hereby agree as follows:

1. **Grant of Signage Easement.** Grantor hereby grants to Grantee an exclusive easement (the “**Easement**”) to maintain signage on the Property, specifically a [REDACTED] (XX) square foot area on the north facing brick wall adjacent to Baltimore Street for a Wall Mural, which easement shall include the right of Grantee and its agents and employees to enter onto the Property

in connection with Grantee's maintenance, repair and replacement of signage located on the Property from time to time. Grantee's use of the Easement and any and all signage maintained by Grantee on the Property shall be at Grantee's expense be in compliance with all laws, rules and regulations of any governmental authority having jurisdiction.

2. Character of Easement. Grantor shall not do or cause to be done anything to limit, restrict or interfere with Grantee's use of the Property or otherwise unreasonably interfere with the rights granted to Grantee herein.

3. Term of Easement; Termination of Easement.

a. The Easement shall have an initial term of five (5) years from the date hereof (the "**Term**"); provided, however, that at any time during the Term, Grantee may elect to give Grantor written notice of termination of the Easement, which shall be effective sixty (60) days following Grantor's receipt of such notice. If not sooner terminated and provided Grantee is not in default of the terms of this Agreement, the Easement shall automatically renew for additional successive five (5) year terms.

b. As consideration for the Easement herein granted, Grantee shall pay Grantor the sum of Ten and No/100 Dollars (\$10.00).

c. After termination of the Easement (the "**Easement Termination**"), upon the request of Grantor, Grantee (together with Grantor) shall execute, acknowledge, deliver and record in the Recorder's Office of Will County, Illinois a termination and release of the Easement.

d. Upon receiving the Grantee's Notice of Termination, Grantor shall have thirty (30) days thereafter to request that the Grantee transfer ownership of the signage on the Property to the Grantor. Otherwise, upon the termination of this Agreement, shall cause its signage to be removed from the Signage Parcel at Grantee's cost and expense.

4. Maintenance of Easement. Grantee shall have the right and responsibility to install, maintain, repair, and replace signage, power wash, tuck point, and paint areas of the building associated with the Easement, and all other repairs or charges associated with the existence or use of the Easement. In the event that Grantee paints any areas of the building associated with the Easement, Grantee shall paint it in a color and manner that is the substantially similar to the color of the existing areas. In the event that Grantee finds it necessary to make any physical improvements located or to be located in or on the Easement, Grantee shall provide at least fourteen (14) days-notice to Grantor before such improvements can be made, and Grantor shall have no right to prevent such improvements unless the improvements will substantially alter the structural integrity of the building located on the Property. Notwithstanding anything contained in this Agreement, Grantee shall have no affirmative obligation to construct or cause the construction of any improvements on Grantor's Property. In the event that Grantor finds it necessary to make any physical improvements located or to be located in or on the Easement,

Grantor shall provide at least fourteen (14) days-notice to Grantee before such improvements can be made, and such improvements shall not violate Section 2 of this Agreement.

5. Insurance. For so long as the Easement is in effect, Grantee shall maintain liability insurance with respect to the Easement in a coverage amount not less than One Million Dollars (\$1,000,000.00). Upon the request of Grantor, Grantee shall provide to Grantor evidence of such insurance (including, without limitation, insurance certificates and copies of insurance policies, together with paid receipts therefor) not more frequently than annually. From and after the Easement Termination, Grantee shall have no obligation to maintain any insurance with respect to the area formerly subject to the Easement.

6. Successors and Assigns. The rights and obligations hereunder of the parties hereto (a) are made for the benefit of and shall be binding upon Grantor and Grantee and their respective successors and assigns, and (b) will constitute covenants running with the land.

7. Indemnification. Grantee shall indemnify Grantor and its agents, servants, contractors, managers, members, partners, directors, shareholders, officers, employees, invitees, tenants, guests, licensees and each of their respective agents, servants, contractors, managers, members, partners, directors, shareholders, officers, employees, invitees, tenants, guests and licensees, and shall hold all such persons harmless from and against, any and all loss, cost, liability, damage, injury, death, expense, claim (including, without limitation, any claim to a lien caused by or through Grantee), action or cause of action (a “**Loss**”), including, without limitation, attorneys’ fees and expenses, which may arise by reason of the willful or negligent acts or omissions of Grantee or anyone claiming or acting through Grantee (including, without limitation, Grantee’s agents, servants, contractors, managers, members, partners, directors, shareholders, officers, employees, invitees, tenants, guests, licensees and each of their respective agents, servants, contractors, managers, members, partners, directors, shareholders, officers, employees, invitees, tenants, guests, and licensees) in relation to the Easement or the use thereof.

8. Entire Agreement. This instrument contains the entire agreement between the parties hereto relating to the rights and obligations described herein.

9. Notices. Any notice, request, demand, instruction or other document to be given hereunder or pursuant hereto (a “**Notice**”) shall be in writing and personally delivered or sent by: (a) first class, registered or certified mail, postage prepaid, return receipt requested, (b) nationally recognized overnight carrier, or (c) electronic mail, with the original Notice sent via overnight delivery addressed to the address of the party in question set forth below and copies to the parties designated below or to such other address as either party may designate by Notice pursuant to this Section. Notices shall be deemed given (x) three business days after being mailed as provided in clause (a) above, (y) one business day after delivery to the overnight carrier as provided in clause (b) above, or (z) on the day of the transmission of the electronic mail, so long as it is received by 5:00 p.m. (Chicago time) on such day and the original of such Notice is received the next business day via overnight delivery as provided in clause (c) above.

Notices to Grantor: Kenneth W. Frey
102 S. Water Street
Wilmington, IL 60481

Notices to Grantee: City of Wilmington
Attn: City Clerk
1165 S. Water Street
Wilmington, Illinois 60481

Notices to Grantee copy to: Mahoney, Silverman & Cross, LLC
822 Infantry Drive
Suite 100
Joliet, Illinois 60435
Attn: Bryan M. Wellner
Email: bwellner@msclawfirm.com

The addresses and addressees for purposes of this Section may be changed to any other address or addressee in the continental United States by giving written notice of such change in the manner provided herein for giving Notices. Unless and until such written notice is delivered, the last address and addressee stated by written notice, or provided herein if no written notice of change has been delivered, shall be deemed to continue in effect for all purposes hereunder.

10. Headings. All headings used in this Agreement are for convenience of reference only, and shall not affect the construction or interpretation of this Agreement.

11. Further Assurances. Grantor and Grantee hereby agree to do, execute, acknowledge and/or deliver all such further acts, instruments, documents and assurances and to take all such further action as shall be necessary or desirable to fully carry out the provisions of this Agreement.

12. Waivers, Modifications. No waiver of any of the obligations or requirements set forth herein shall be made or effective unless such waiver shall be in writing signed by the party intended to be bound thereby, and only to the extent of such written waiver. This Agreement (except for the addresses contained in Section 11 above) may not be modified in any respect whatsoever, in whole or in part, except by written instrument signed by the party intended to be bound thereby, which written instrument shall be recorded in the Recorder's Office of Will County, Illinois.

13. Governing Law. This Agreement shall be construed and governed by the internal laws (and not the laws of conflict of laws) of the State of Illinois.

14. Severability. If any term, covenant, condition or provision hereof is unlawful, invalid, or unenforceable for any reason whatsoever, and such illegality, invalidity, or unenforceability does not affect the remaining parts of this Agreement, then all such remaining

parts hereof shall be valid and enforceable and have full force and effect as if the invalid or unenforceable part had not been included.

15. Recording. Grantee shall cause this Agreement (and the Exhibits attached hereto) to be recorded with the Will County Recorder.

16. Relationship of Parties. Nothing in this Agreement shall be deemed to create any joint venture or partnership between the parties. Neither the Grantor nor the Grantee shall have the power to bind or obligate the other, except as and to the extent expressly set forth in this Agreement.

[Signatures on Following Page]

IN WITNESS WHEREOF, the parties hereto have executed this Agreement as of the day and year first above written.

GRANTOR:

KENNETH W. FREY

By: _____

Name: Kenneth Frey

GRANTEE:

CITY OF WILMINGTON,

an Illinois municipal corporation

By: _____

Name: _____

Its: _____

STATE OF _____)
) SS.
COUNTY OF _____)

I, the undersigned, a Notary Public in and for the County and State aforesaid, DO HEREBY CERTIFY, that Kenneth Frey, personally known to me, and personally known to me to be the same person whose name is subscribed to the foregoing instrument, appeared before me this day in person, he signed and delivered the said instrument pursuant to the proper authority given by such company, as his free and voluntary act, and as the free and voluntary act and deed of said company, for the uses and purposes therein set forth.

Given under my hand and Notary Seal, this __ day of _____, 2023.

Notary Public

STATE OF ILLINOIS)
) SS.
COUNTY OF _____)

I, the undersigned, a Notary Public in and for the County and State aforesaid, DO HEREBY CERTIFY, that Ben Dietz personally known to me to be the Mayor for the City of Wilmington, an Illinois municipal corporation, and personally known to me to be the same person whose name is subscribed to the foregoing instrument, appeared before me this day in person and acknowledged that as such Mayor, he signed and delivered the said instrument pursuant to the proper authority given by the City of Wilmington corporate authorities, as his free and voluntary act, and as the free and voluntary act and deed of said corporation, for the uses and purposes therein set forth.

Given under my hand and Notary Seal, this ___ day of _____, 2023.

Notary Public

EXHIBIT A

Legal Description of the Property

EXHIBIT B

Wall Mural



City of Wilmington

1165 S. Water Street Wilmington, IL

Phone: 815-476-2175 ~~815-476-2175~~ www.wilmington-il.com

Received

JUL 13 2023

City of Wilmington

Memo

To: Jeanine Smith,
CC: James Gretencord , Nancy Gross
From: Ryan B. Foster
Date: ~~06/04/2022~~ 7-13-2023
Subject: Lime Sludge Removal, Committee approval request.

East Lagoon Removal

East Lagoon is one of two lagoons currently functioning. This approval is for the removal of the lime sludge from the East Lagoon and land application. FY2023, 750 wet tons were removed from this lagoon. Removal this year should be at minimum 750 up to 1000 wet tons. Price Quoting as follows:

- **New Era Spreading:** \$53.00 per dry ton (Roughly \$17.00 per wet tons)
- **Synagro:** \$70.41 per dry ton (Roughly \$23.24 wet tons)

West Lagoon Removal

West Lagoon is currently Out of Service until reactive maintenance can be performed. Lime sludge needs to be removed in order to gain access to make repairs. New Era cleaned majority of the West Lagoon Fall of 2023. There was a significant amount of lime in west Lagoon $\frac{2}{3}$ to $\frac{3}{4}$ of overall volume was removed. Request for approval for perimeter cleaning and removal not to exceed \$10,000.00.

Conclusion

Removal of lime sludge from the east lagoons MUST be removed by this fall since this is only active lagoon. The IEPA land application permit was renewed this year. The primary focus of this request is the removal and cleaning of the east lime lagoon in order to continue operations. Secondly, Approval to finish cleaning the west Lagoon and perimeter. Both Companies have been awarded past work and are familiar with our lime storage lagoons.

Line Item: 02-21-6730 Lime Sludge Disposal, FY2024 Budget \$60,000.00, Remaining balance \$58,500.00.

Respectfully,

Ryan B. Foster
City of Wilmington
Water Department
Lead Operator, ROINC
rfoster@wilmington-il.com

New Era Spreading Inc.

7294 N. Vincennes Trail

Grant Park, IL 60940

(815) 693-7695 ~ Nick

Email ~ Neweraspreading@gmail.com

Bid Proposal

New Era Spreading Inc. would like to propose a price of \$53.00 per dry ton for the year of 2023. Each semi load hauls 8 dry tons per load. For perimeter cleaning and dry lime removal of the west lagoon, an excavation price of \$5,000.00-\$10,000.00 is estimated and not to exceed \$10,000.00. For dry lime hauling and land application per EPA guidelines, a cost of \$525 per 20-ton load will be charged.

Nick Hancock, President

New Era Spreading Inc.

City of Wilmington

June 30, 2023

Ryan Foster
Operations Manager
City of Wilmington
745 Widows Road
Wilmington, Illinois 60481

RE: Cleanout of lime sludge lagoon and land application

Mr. Foster

Synagro is pleased to submit this proposal for the removal of lime sludge and land application. The pricing detailed herein provides for the following:

Pricing:

- Lime Sludge Removal and Land Application.....\$70.41 per dry ton
 - Synagro expects to start work in late summer/early fall 2023.
 - Gallons estimated at 750,000 and expect 1,163 dry tons at 33% solids.
 - Owner will need to provide land application permit and approved product.
 - Synagro to slurry & pump liquid to tankers, transport to field for land application

- Mobilization Fee.....\$15,525.00 per event
 - Includes mobilization and demobilization of all equipment and staff.
 - Synagro anticipates only one event, unless otherwise instructed by Owner.

Key elements of our proposal are detailed below:

- *Mobilization:* This proposal is based upon one mobilization of equipment and manpower. Any stop in work that requires remobilization will be charged accordingly.



- *Access:* Synagro anticipates the Owner will provide uninterrupted access from the worksite for the entire duration of the project during all operating hours as needed.
- *Weather Related Lost Time:* Any lost days due to freezing or unworkable conditions can push back the completion schedule. Synagro will not be accountable for lost time due to weather. In the event freezing conditions occur, additional charges will apply as needed.
- *Landfill Disposal:* Price does not include disposal or tip fees at landfill.
- *Terms:* Definitive 30-day payment terms, fuel surcharge for diesel over \$5.50 per gallon, relief for force majeure/uncontrollable circumstances, change in law, and compensation for early termination may apply.
- *Prevailing Wage:* This proposal is based upon current prevailing wage rates. However, there is current legislation that may change how prevailing wage rates are applied. If there is a change-in-law, then both parties agreed to immediately amend the contract and price.

Our proposal is delivered in good faith, and we are prepared to enter a mutually acceptable contract. Please note that this proposal is based on Synagro's standard terms and conditions and shall be strictly non-binding upon Synagro until all parties execute a binding contract. This proposal shall not obligate Synagro to negotiate an agreement and any of the terms of the contract shall be subject to Synagro's approval, at its discretion. Pricing is valid for 60 days and may vary until the final scope is determined and the contract is signed.

We appreciate the opportunity to submit this proposal for your consideration and look forward to the opportunity to provide our services. Should you have any questions, please contact me.

Sincerely,

Will Walker

Will Walker

Synagro Area Sales Manager

Cell: 224-242-0666

Email: wwalker@synagro.com



New Era Spreading Inc.
 7294 N. Vincennes Trail
 Grant Park, IL 60940

Invoice

2022
 Costs

Bill To
City of Wilmington 1165 South Water Street Wilmington, IL 60481

Date	Invoice No.	P.O. Number	Terms	Project
09/16/22	383			

Item	Description	Quantity	Rate	Amount
Lowboy	Deliver & Pick Up Excavator Truck#20	1	750.00	750.00
Lagoon	Lagoon Work	26.25	200.00	5,250.00
Lime	Hauled Lime ~ Dry tons 08/29 - 09/01	24	500.00	12,000.00
Lime	Hauled Liquid ~ Wet tons 08/31	750	16.00	12,000.00

PAST DUE

Thank you for your business.	Subtotal	\$30,000.00
	Sales Tax	\$0.00
	Total	\$30,000.00